



Volume 1	Issue 2	June (2021)	DOI: 10.47540/ijias.v1i2.195	Page: 124 – 133
----------	---------	-------------	------------------------------	-----------------

## Sustainability Implementation of UI Green Metric World University Rankings Energy & Climate Change (EC) Indicators: A Case Study of MUET Gymnasium Fitness Facility

Arsal Mehmood<sup>1</sup>, Toussef Ali Shahani<sup>2</sup>, Murtaza Ali Khuharo<sup>3</sup>

<sup>1,2,3</sup>Department of Electrical Engineering, Mehran University of Engineering & Technology, Sindh, Pakistan

**Corresponding Author:** Arsal Mehmood; Email: [fl6el74@students.muett.edu.pk](mailto:fl6el74@students.muett.edu.pk)

### ARTICLE INFO

*Keywords:* Carbon Dioxide, Renewable Energy Source, Sustainability, Techno-Economic Analysis.

*Received* : 15 March 2021

*Revised* : 05 June 2021

*Accepted* : 11 June 2021

### ABSTRACT

Mehran University of Engineering & Technology is a public university established in 1973. With seventeen faculties of multi-disciplines and having more than 7,500 students, MUET has made lots of achievements. In 2019, MUET is ranked 271 in the world, 2<sup>nd</sup> in Pakistan, 1<sup>st</sup> in Sindh Province, and slotted 275<sup>th</sup> in terms of Energy and Climate change (EC) indicators implementations on Sustainable development by UI GreenMetric World University Rankings. UI GreenMetric is a sustainability-based ranking whose aim is to provide rankings of universities all over the world based on their efforts for the implementation of pre-define indicator criteria. One of the criteria for this ranking is the Energy and Climate change (EC) indicator which had a most 21 percent weightage. In this review, this paper presents a detailed analysis for the implementation of EC indicators of UI GreenMetric World University Rankings to reduce carbon dioxide footprints and maintain sustainability at MUET gymnasium fitness facility. In this mechanism, an Energy Efficient Flywheel-Based KERS (Kinetic Energy Recovery System) Bicycle Generator is designed and developed. Additionally, a techno-economic (Energy, Cost and CO<sub>2</sub> emission saving) beneficial analysis of generators with their usage as a free renewable energy source to overcome luminosity demand of MUET gymnasium fitness facility by an efficient LED lighting system and their relative relation with the EC indicator implementation is also discussed.

### INTRODUCTION

Pakistan is the fifth most populous country in the world. Electricity is the basic need of human life. With the growing population, the need for renewable electrical power and its usage is also increasing day by day. Every year the consumption rate of electricity is increasing globally, but in Pakistan, the production rate is not growing sufficiently which consequently resulted in load shedding and an increase in electricity price levels. Besides, fossil fuel cost is increasing day by day as well as government is also taking steps to make use of renewable sources. Today climate change is the biggest threat we faced. So, now it is time to gives

attention to generating power through renewable energy sources, instead of conventional energy sources (Pangaribuan, 2018). According to National Electric Power Regulatory Authority (NEPRA) annual report 2018-2019.

Figure 1 Show the total energy division of Pakistan in Mega Watt from the different energy source. From the below figure it is observed that most of the electricity in Pakistan is generated from thermal energy sources and we know that thermal sources are responsible for global warming and climate change (Shenoy, 2018).

Figure 1. Represents Overall Installed Capacity of Pakistan.

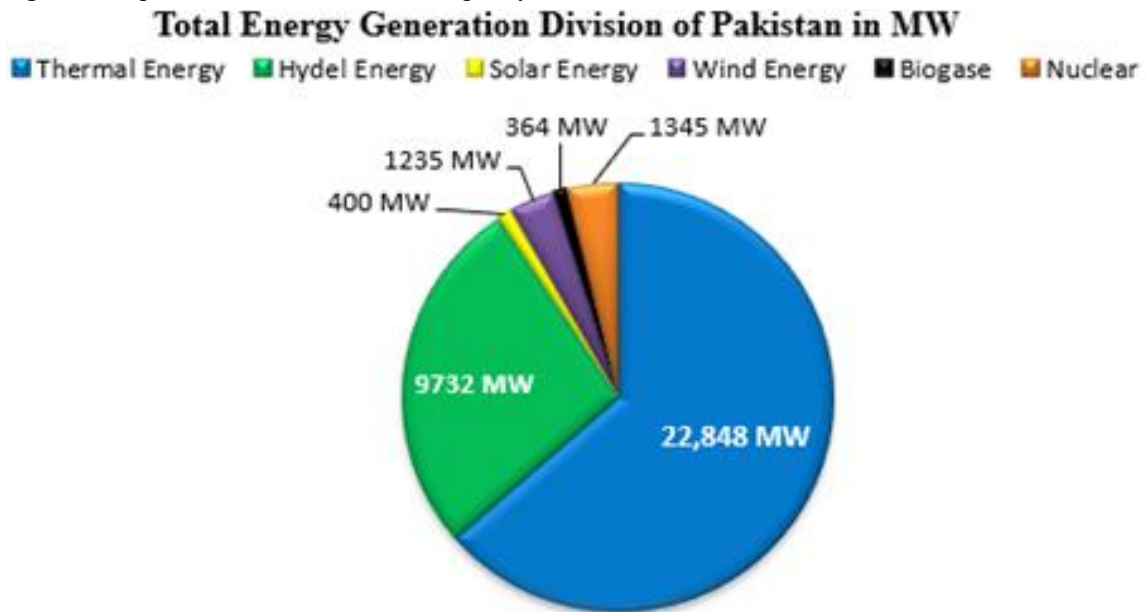

Figure 2. Represents Overall Installed Capacity of Pakistan.

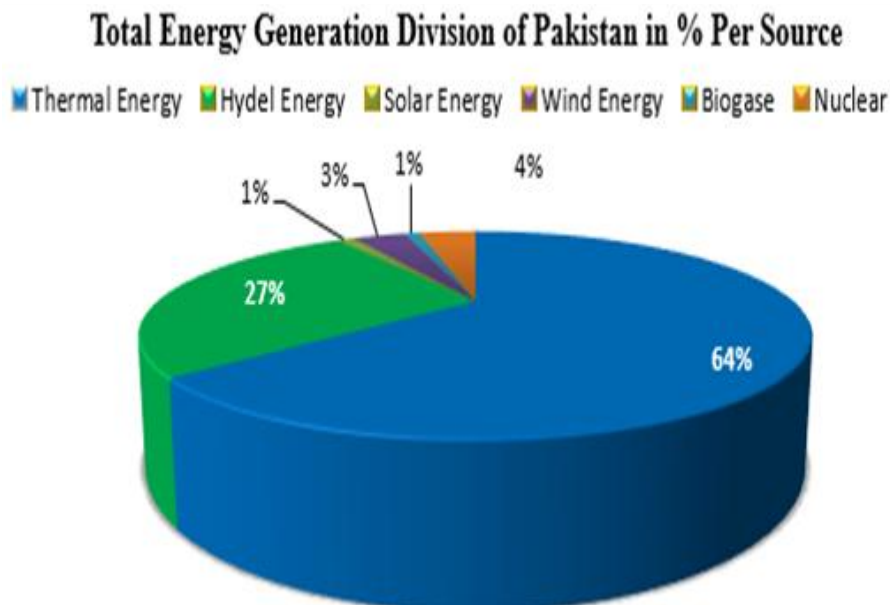

Figure 2 shows the main one of the main elements that Pakistan is listed in the Global Long-term Climate Risk Index (CRI) top 10 countries (Megalingam, 2012).

In Paris Agreement 2015, United Nations Framework Convention on Climate change (UFCCC) presents the idea that developing countries needed to utilize environmentally friendly technologies to contribute to reducing emissions and prevent the world from global warming (United Nations Climate Change Conference, 2015). For that we need to focus on finding alternative renewable energy power plants, especially

environmentally green and eco-friendly (F. S. Prabowo, 2018). One type of an environmentally friendly clean and green energy power plant is an off-grid eco-friendly flywheel fitness exercise static KERS bicycle generator (Chalermthai, 2015).

The human body can produce a significant amount of energy and Human muscle activity has the potential to produce power that can be used for low power applications especially lighting load applications. The use of exercise equipment for green energy sources would be an exciting experience for participants as well as it provides a means to generate power along with cycling

exercise (Megalingam, Pedal Power Generation, 2015).

Flywheel-Based KERS Bicycle Generator can tap human energy to produce electricity quickly and efficiently. The primary function of the flywheel is to work as an energy accumulator and to reduce the fluctuation in speed. It absorbs the energy when demand is less and releases the same when it is required, which is the technical and engineering aspect of harvesting energy (Uddin, 2015). This flywheel technology inherits many advantages that are environmentally friendly and has low maintenance, long life with no degradation. That is why even NASA (National Aeronautics and Space Administration) Glenn Research center has employed Flywheel energy storage systems for over three decades (Suhalka, 2014).

The objective of this research is to develop a practical prototype of an OFF-Grid Green Harvesting Bicycle Generator with a highly efficient flywheel energy storage system, which could act as well as an OFF-Grid Battery Charging System. This model will be proposed as a technological solution to minimize and to overcome the lighting load demand dependency of MUET Gymnasium on Water & Power Development Authority (WAPDA) and it will be suggesting as a proposal for the implementation of UI Green Metric (UIGM), Energy and Climate Change (EC) indicators (Zaman, 2017).

Figure 3 Represents Energy and Climate Change Indicator of Universitas Indonesia Green Metric World University Ranking.

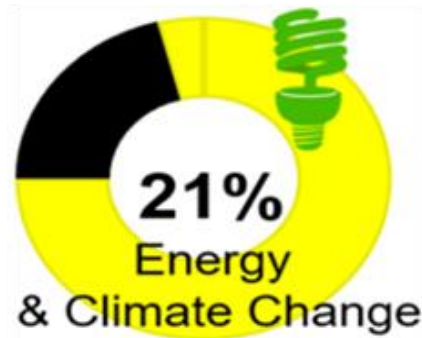
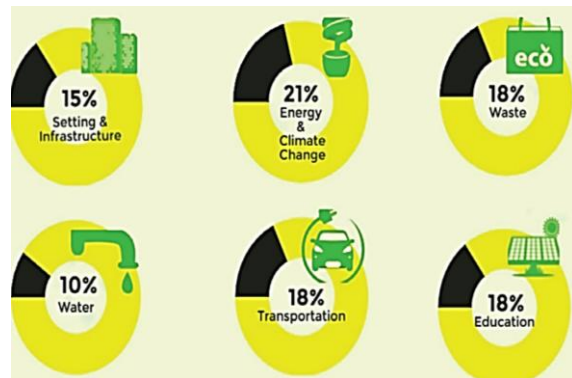

Figure 4 Represents Criteria and Indicators of Universitas Indonesia Green Metric World University Ranking (UI Green Metric)



According to the Ranking released by Universitas Indonesia Green Metric in 2019, MUET is 271<sup>st</sup> Worldwide, 2<sup>nd</sup> in all over Pakistan while 1<sup>st</sup> in Sindh Province University rankings. Although, in terms of implementing Energy and Climate Indicators of UIGM they listed MUET 275<sup>th</sup> best globally.

Figure 5. Represents Global Ranking of Mehran University of Engineering & Technology in Green Metric World University (UI GreenMetric, 2019)

Ranking	University	Country	Total Score	Setting & Infrastructure	Energy & Climate Change	Waste	Transportation	Water	Education & Research
271	Mehran University of Engineering & Technology	Pakistan	5625	1050	1100	675	1100	425	1275

Figure 6 Represents Global Ranking of Mehran University of Engineering & Technology in Green Metric World University for the Implementation of Energy and Climate Change Indicators (UI GreenMetric, 2019).

Ranking	University	Country	Total Score	Setting & Infrastructure	Energy & Climate Change	Waste	Transportation	Water	Education & Research
275	Mehran University of Engineering & Technology	Pakistan	5625	1050	1100	675	1100	425	1275

Our proposed mechanism is beneficial in maintaining sustainability and improving global ranking through the implementation of EC indicators.

Alternatively, this research also gives a comparative analysis of the present less efficient 60 Watts tube light Lighting System with the highly efficient 6 Watts LED lighting System in terms of Electrical Energy Unit Consumption Saving, its Cost Saving, and its related Green House Gases (GHG) emission saving.

increasing by 10% but when there is no simultaneous increase in production, and then the consequences resulted in the form of increased electricity prices and load shedding. Alongside the availability of fossil fuels is getting reduced. In this case study, we have proposed the general technique to produce electricity from mechanical energy. The concept of this study is to use the wasted kinetic energy in the gymnasium while work out to produce electricity.

**METHODS**

In human life, electricity is the basic requirement. Every year electricity consumption is Figure 7. Research Methodology Framework.

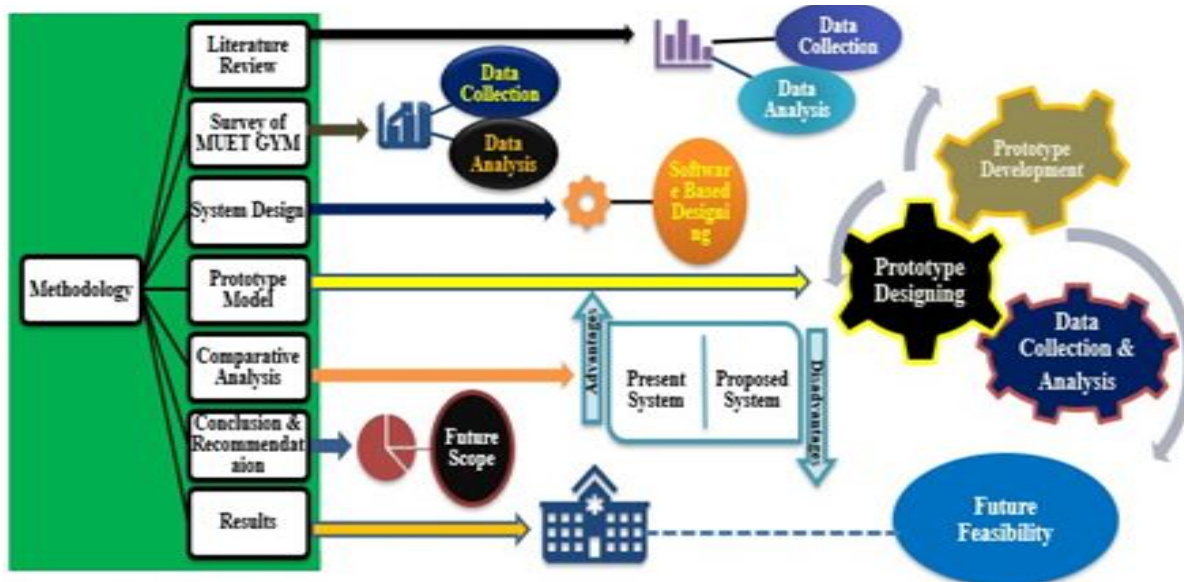
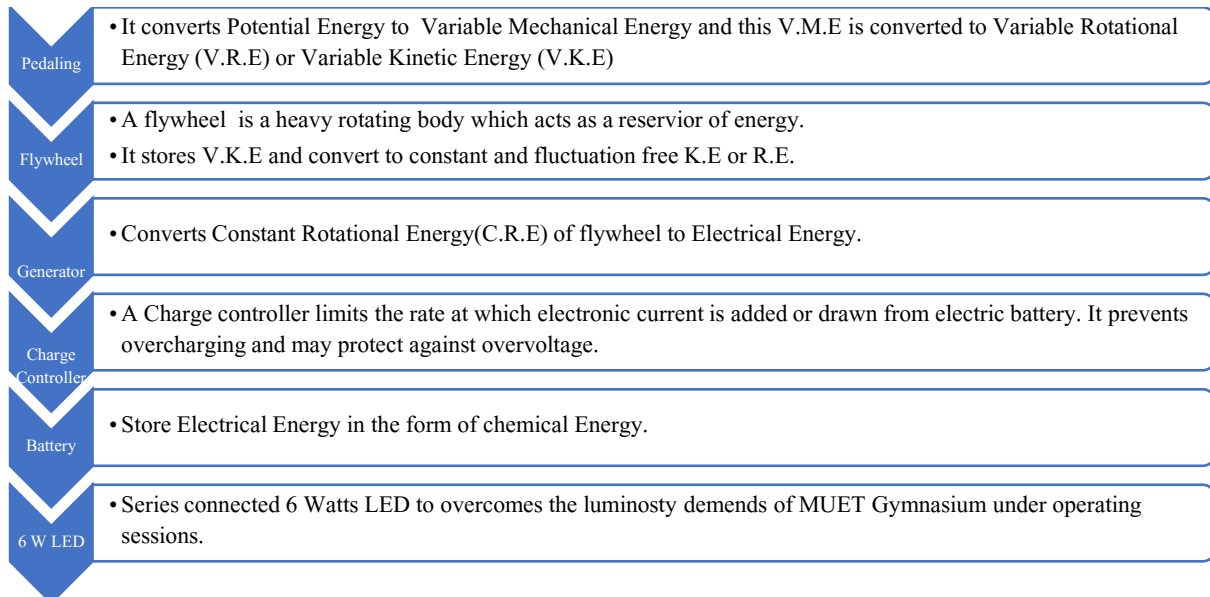

Table 1. Research Flow Diagram



Data Collection & Surveys

In this review, a survey is performed for the data collection from MUET Gymnasium fitness facility. The questionnaire method is used for the determination of GYM operating hours, Operating sessions, Power ratings present appliances, Overall load demand, Lighting load demand in the respective sessions, Quantity of luminosity appliances, Frequency of peoples in the respective sessions, and their equipment's of concern.

Table 2. Data collection from Gymnasium fitness facility

DATA	SPECIFICATIONS
NO. OF TUBELIGHTS	30
ENERGY CONSUMPTION OF 1TUBELIGHT	60.70 W
TOTAL LIGHTENING CONNECTED LOAD	1.8 KW

Table 3. Represents operating hours of Gymnasium.

GYMNASIUM OPERATING HOURS	
1 SESSION	9 AM - 2:30PM
2 SESSION	3:30 PM - 9 PM
TOTAL OPERATION HOURS	11 HOURS

Table 4. Represents load demand of fitness facility.

LOAD CONSUMPTION DURING TOTAL OPERATING HOURS	
1 SESSION	1 hr. (IN BED LIGHT) 8 TUBELIGHT
2 SESSION	6 PM- 9:30 PM
TOTAL LOAD CONSUMPTION	480W + 6.3KW=6780W
HOURS	

Data Analysis

The results of the collected data analysis are as follows:

Table 5. Represents classifications of PMDC Generators with present and proposed lighting capacity.

Classification of DC PMDC GENERATOR	PRESENT TUBELIGHT 60W TUBELIGHT SYSTEM 1 TUBELIGHT= 60W	PROPOSED 6W LED LIGHTING SYSTEM 6 WATTS 1 LED = 6W
50 WATTS	NOT A SINGLE TUBELIGHT	8 LED
100 WATTS	1 TUBELIGHT	16 LED
250 WATTS	4	41 LED
300 WATTS	5	50 LED
500 WATTS	8	83 LED
1000 WATTS	16	166 LED



*System Designing*

Design of the proposed system is given by:

Figure 8. Represents Proposed System Design with 250W PMDC, 24 V battery, Charge Controller, Switches and Series connected 6W 40 LED (1st session 15 LED + 2ND session 25 LED) fitness facility through Frizing Software.

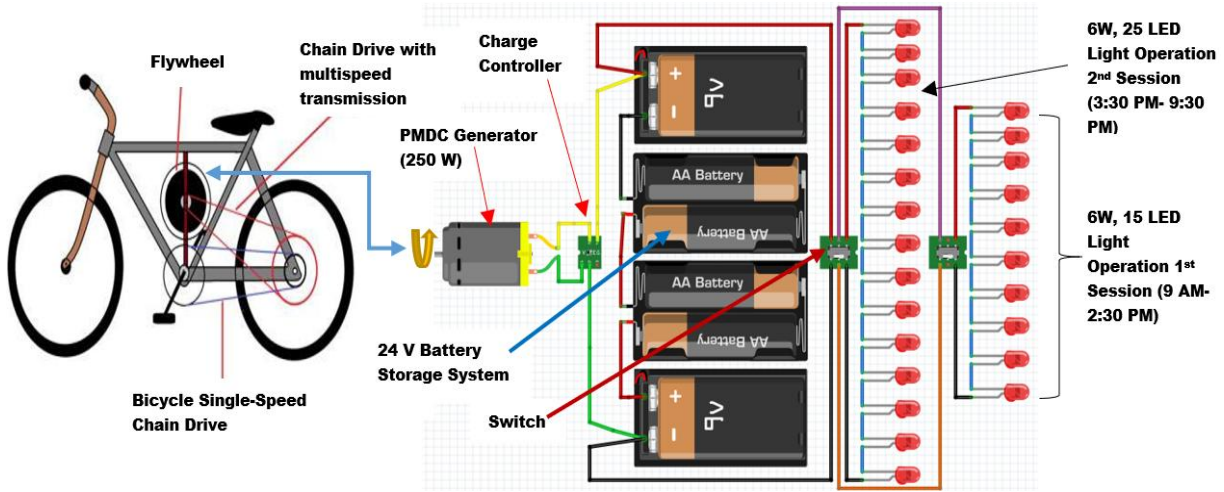

*Prototype Internal Mechanism*

Figure 9. Represents prototype model internal mechanism.

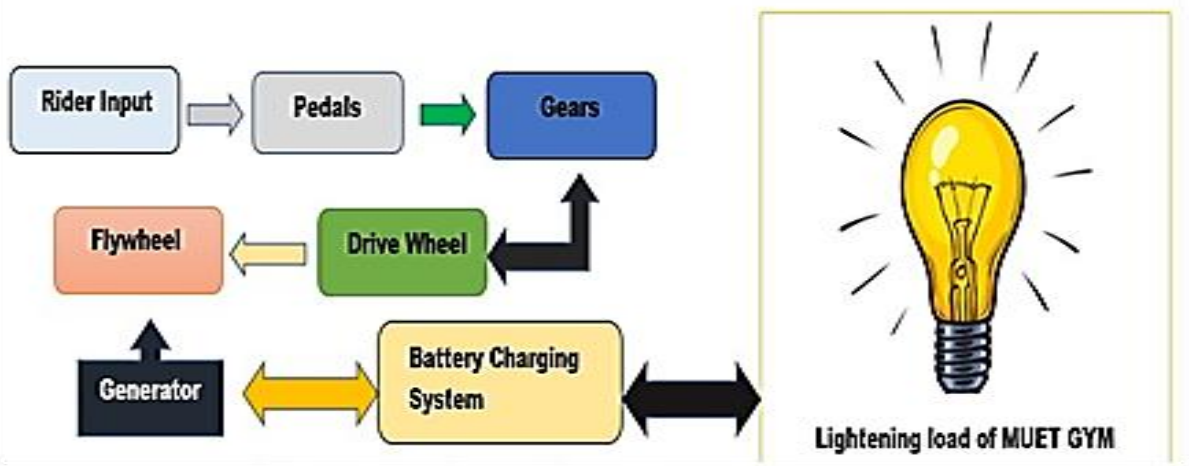

*Hardware Model Components Confurigation*

The below figure represents the basic configuration of the “Off-Grid Green Energy Harvesting (EH) Flywheel Based Bicycle Generator” with specialized and unique flywheel energy accumulation technology integration.

Generator” with specialized and unique flywheel energy accumulation technology integration.

Figure 10. Represents Hardware model of an Off-Grid Eco-friendly Green Energy Harvesting (EH) Flywheel Based Bicycle Generator.



**RESULTS AND DISCUSSION**

The main objective of this prototype development research is to initiate a self-sufficient gymnasium phenomenon that can sustain its all-lighting load by the utilization of waste mechanical energy during workout and convert it down into electrical energy. This project presents an economical and technological solution of load shedding and as well as it could serve as a backup energy resource or uninterruptable power supply (UPS) by using the battery.

Additionally, power production by the flywheel-based bicycle generator provides us an opportunity to minimize atmospheric pollution which is nowadays a government policy. A flywheel-based bicycle generator is very cheap. Since we know that cost of fossil fuel is increasing day by day and this project is not depending on those.

It serves dual purposes benefits simultaneously. Firstly, physical fitness through exercise of muscles, and legs. Secondly, green, and eco-friendly power generation through those healthy activities at the same time.

**Calculations for Energy Saving**

The initial result of the study for energy-saving and its cost-saving is given by the formula as:

$$C = A - B(1)$$

A= (1<sup>st</sup> session operating hours × Sum of 60 W connected load operates in 1<sup>st</sup> session) + (2<sup>nd</sup> session operating hours × Sum of 60 W connected load operates in 2<sup>nd</sup> session)

B= (1<sup>st</sup> session operating hours × Sum of 6 W connected load operates in 1<sup>st</sup> session) + (2<sup>nd</sup> session operating hours × Sum of 6 W connected load operates in 2<sup>nd</sup> session)

Figure 11. Represents 60 W Tube light Lightning System Load Consume (A).

**60 W Tube light Lightning System Load Consume (A)**

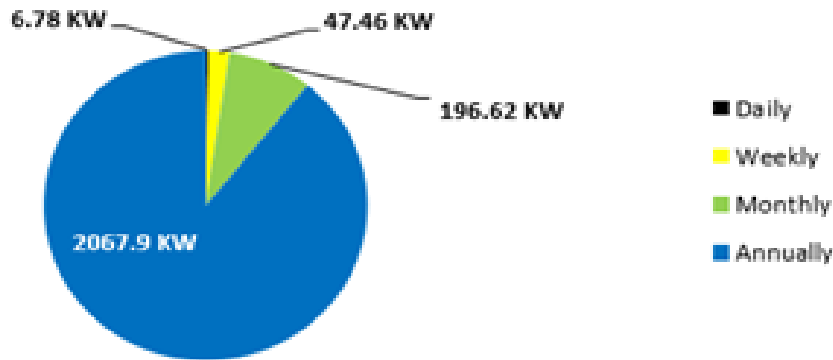

Figure 12. Represents 6 W LED Lightning System Load Consume (B).

**6 W LED Lightning System Load Consume (B)**

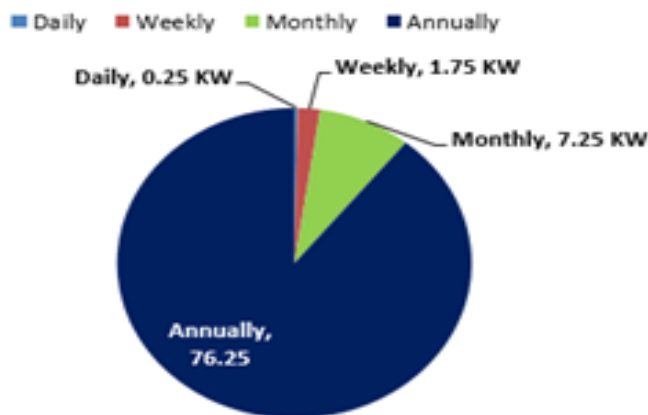

Figure 13. Energy Consumption Saving by using 6 W LED System C = (A-B).

**Energy Consumption Saving by using 6 W LED System C = (A-B)**

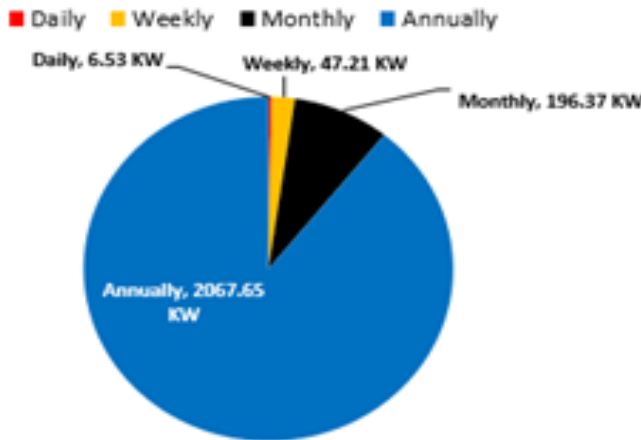

Table 6. Represents Initial Results of the Study for Energy Saving.

Comparison	60 W Tube light Lightening System Load Consume (A)	6 W LED Lightening System Load Consume (B)	Energy Consumption Saving by using 6 W LED System C = (A-B)
Daily	6.780 KW	250 W	6530 KW
Weekly	47.46 KW	1.750 KW	47.21 KW
Monthly (29 Days)	196.62 KW	7.250 KW	196.370 KW
Annually (305 Days)	2067.9 KW	76.250 KW	2067.65 KW

**Calculations for Cost Saving**

Cost Saving D,

$D =$

$C \times$

$\gamma$  (Error! Bookmark not defined.)

C = Energy unit saving (daily/weekly/monthly)

$\gamma$  = Cost Per Price of a single unit of Energy

Figure 14. Represents Cost Saving (1 Unit = 18 Rupees in Pakistan)

**Cost Saving (1 Unit = 18 Rupees in Pakistan)**

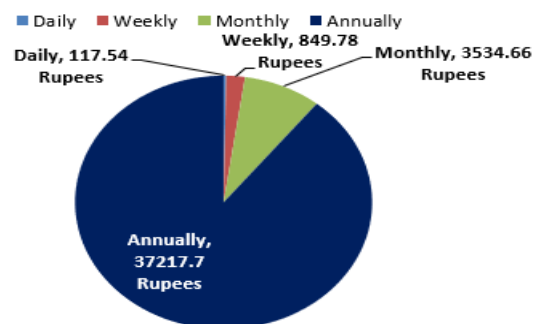



Table 5. Represents Initial Results of the Study for Cost Saving

Comparison	Cost Saving (1 Unit = 18 Rupees in Pakistan)
Daily	117.54 Rupees
Weekly	849.78 Rupees
Monthly (29 Days)	3534.66 Rupees
Annually (305 Days)	37217.7 Rupees

**Calculations for Co<sub>2</sub> Emission Saving**

Primary electricity production in Pakistan from thermal (oil, natural gas, etc.) as shown in Figure1, and

$$1\text{KWH} = 0.001\text{MWH}$$

Since,

Energy produces in this proposed “Off-Grid Eco-Friendly bicycle generator” is 100% green. So, there is no Co<sub>2</sub> emission.

Therefore,

The amount of Co<sub>2</sub> Emission saving through a proposed idea as compared to 60 W tube light system is given by the formula as:

CO<sub>2</sub> Emission Saving = Energy consumes while 60W system operates in KWH × CO<sub>2</sub> Emission factor for solar, wind, or other sources × 0.001 MWH per KWH.

The CO<sub>2</sub> Factor for wind and solar is 0.600-ton Co<sub>2</sub> per Megawatt-hours. While its value for other sources is 0.501-ton Co<sub>2</sub> per Megawatt-hours according to the Asian Development Bank (Asian Development Bank, 2017).

Figure 15. Represents Carbon Dioxide CO<sub>2</sub> Emissions.

Table 6. Represents Initial Results of the Study for Co<sub>2</sub> Emission Saving

Comparison	CO <sub>2</sub> Emission in 60 W Tube Light System for Wind and Solar Emission Factor=0.501tco <sub>2</sub> Per MWH (Other Source)	CO <sub>2</sub> Emission in 6 W LED System for Wind and Solar Emission Factor=0.600tco <sub>2</sub> Per MWH (Wind & Solar)
Daily	0.00339 Ton of CO <sub>2</sub>	0.004068 Ton of CO <sub>2</sub>
Weekly	0.02377 Ton of CO <sub>2</sub>	0.0284 Ton of CO <sub>2</sub>
Monthly (29 Days)	0.09850 Ton of CO <sub>2</sub>	0.1220 Ton of CO <sub>2</sub>
Annually (305 Days)	1.0360 Ton of CO <sub>2</sub>	1.484 Ton of CO <sub>2</sub>

**Carbon Dioxide CO<sub>2</sub> Emission**

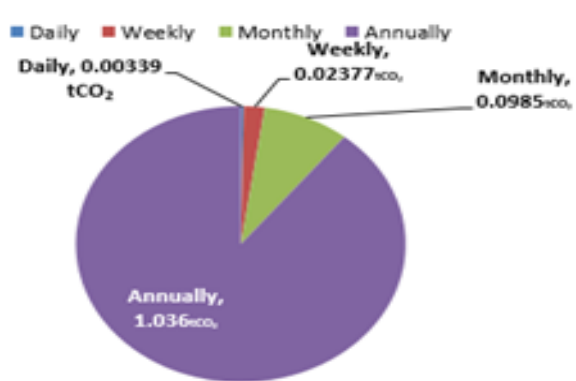

Figure 16. Represents CO<sub>2</sub> Emission in 6 W LED System for Wind and Solar Emission Factor=0.600tCO<sub>2</sub> per MWH (Wind & Solar).

**CO<sub>2</sub> Emission in 6 W LED System for Wind and Solar Emission Factor=0.600tco<sub>2</sub> Per MWH (Wind & Solar)**

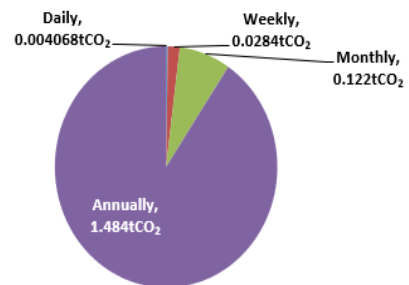

Table 8. Represents Overall Results.

Energy Consumption Comparison	60 W Tube light Lightening System Load Consume (A)	6 W LED Lightening System Load Consume (B)	Energy Consumption Saving by using 6 W LED System C = (A-B)	Cost Saving (1 Unit = 18 Rupees in Pakistan)	CO2 Emission in 60 W Tube Light System for Wind and Solar Emission Factor=0.501tco2 Per MWH (Other Source)	CO2 Emission in 6 W LED System for Wind and Solar Emission Factor=0.600tco2 Per MWH (Wind & Solar)
<b>Daily</b>	6.780 KW	250 W	6530 KW	117.54 Rupees	0.00339 Ton of CO2	0.004068 Ton of CO2
<b>Weekly</b>	47.46 KW	1.750 KW	47.21 KW	849.78 Rupees	0.02377 Ton of CO2	0.0284 Ton of CO2
<b>Monthly (29 Days)</b>	196.62 KW	7.250 KW	196.370 KW	3534.66 Rupees	0.09850 Ton of CO2	0.1220 Ton of CO2
<b>Annually (305 Days)</b>	2067.9 KW	76.250 KW	2067.65 KW	37217.7 Rupees	1.0360 Ton of CO2	1.484 Ton of CO2

**CONCLUSION**

In 2017, there were more than 201 thousand fitness and health clubs worldwide. Along with solar and wind source. We need to focus on some other alternative source of energy. As the population is increasing drastically. So, need to utilize those sources as a source of opportunity, as they can work as small power plants for energy.

Pakistanis are facing an electricity crisis whereas higher electricity tariffs are another burden for the consumers. Higher Education Commission of Pakistan provides students’ academic as well as some extra-curriculum opportunities for the grooming of generation. However, they fetch funding from Government. Mehran University has a gymnasium fitness facility where enough electricity is consumed which could be met through a unique and innovative alternative energy generation prospective to save energy, cost, Green House Gas (GHG)Emission by the implementation of UIGM Energy & Climate indicators through a feasibility analysis approach.

**REFERENCES**

1. International Conference on Environment and Electrical Engineering (EEEIC).
2. Megalingam, R. K. (2012). Pedal Power Generation. 3rd International Conference \$n Emerging Trends in Engineering and Technology.
3. Megalingam, R. K. (2015). Pedal Power Generation.

4. Pangaribuan, P. (2018). Eco-electric energy generator system using human exercise activities. MATEC Web of Conferences.
5. Shenoy, B. B. (2018). Human Muscle Energy Harvesting: Models and Application for Low Power Loads. 8th IEEE India International Conference on Power Electronics (IICPE).
6. Suhalka, R. (2014). Generation of Electrical Power using Bicycle Pedal.
7. Uddin, M. H. (2015). Harvesting green Energy from wastage energy of human activities using gymnasium bicycle at Chittagong City. 3rd International Conference on Green Energy and Technology (ICGET).
8. Zaman, K. M.-U. (2017). Generation of electrical power using gymnasium bicycle. IEEE Region 10 Humanitarian Technology Conference (R10-HTC).