

A NEW ICE BREAKER MODULE CONCEPT

Liviu Moise

University "Dunarea de Jos" of Galati,
Faculty of Naval Architecture, Galati,
Domneasca Street, No. 47, 800008, Romania,
E-mail:liviu.moise@glo-marine.com

Eugen Gavan

University "Dunarea de Jos" of Galati,
Faculty of Naval Architecture, Galati,
Domneasca Street, No. 47, 800008, Romania,
E-mail:eugen.gavan@ugal.ro

Daniela Ioana Tudose

University POLITEHNICA of Bucharest,
313 Splaiul Independentei, 060042,
Bucharest, Romania
daniela.tudor@upb.ro

Costel Iulian Mocanu

University "Dunarea de Jos" of Galati,
Faculty of Naval Architecture, Galati,
Domneasca Street, No. 47, 800008, Romania,
E-mail:costel.mocanu@ugal.ro

ABSTRACT

During the winters, the waters of the rivers freeze because of the low temperatures. In such situations, it is necessary to ensure the traffic of cargo and passenger ships that the formed ice patches be broken and cleared. Ice breakers are used for this purpose. These ships are of special construction that require significant investments. In this paper, a concept of an icebreaker module that can be attached to an existing tugboat in service is proposed. The paper presents a concept adapted to the Danube river and to an existing tug in service on the same river.

Keywords: ice, ice breaker, ice breaker module, stress and strain in ice breaker module

1. INTRODUCTION

One of the most important challenges to which the Romanian authorities responsible for navigation on the Danube River, especially in the cold season, are subject, refers to securing the navigable signal and freeing it from ice. Romania, at the moment, has only one icebreaker, Perseus, anchored in Galati and which recently underwent a modernization operation (Figures 1 a, b). The price of this modernization was very high for a ship as old as the Perseus ice breaker.

The paper presents a proposal for an architectural concept of an icebreaker module that can be attached to an existing tug in service on the Danube.

This ice breaker module, of special metal construction, can be attached by bolting to the bow of the tugboat, and through the classic movement of climbing on the ice and breaking it through the module's own weight, it ensures the creation of a channel for the navigation of other ships.

The structure of the icebreaker module is metallic, covering the bow of the tugboat. The problems that arise are related to the appropriate dimensioning of the resistance structure of the icebreaker mode.

In the following, the design of the metallic resistance structure that must comply with the rules of the classification societies will be carried out, as well as its verification using the Finite Element Method.



before refit



after refit

Figure 1. Perseus icebreaker

**2. ICE BREAKER
MODULE CONCEPT**

The development of the marine and inland goods and passenger's transportation and the northward expansion of the interest areas led to a necessity for navigation on frozen routes. In Romania, especially on the winter time when the Danube river can be blocked by the ice it is need to ensure waterways for ships sailing upstream or downstream on the river.

The main idea of the project to attach to a tug or pusher vessel an

additional structure, installed only when needed, with the purpose of to assure inland navigation in winter time. This concept is presented in Figure 2. In these figures you can see the shape of the ice breaker module (Figure 2 a) and the tug (Figure 2b)to which it will be attached by means of solid steel bolts. The module - tugboat assembly is presented in Figure 2 c.

The ice breaker module will rotate around the bolt joint climbing on the ice and then breaking it by its own weight.

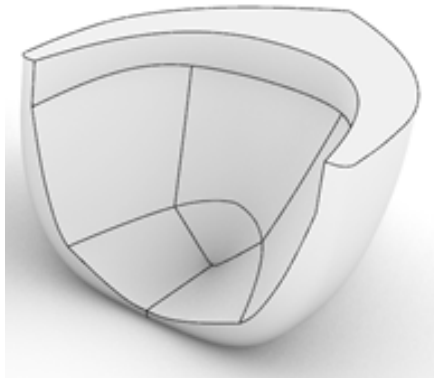

a) icebreaker module

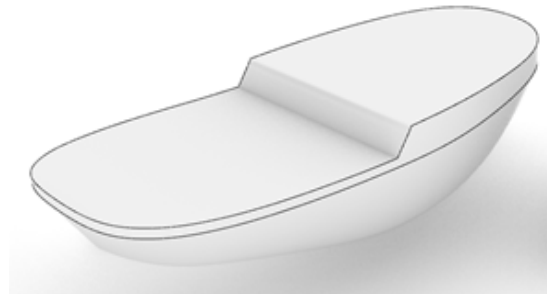

b) tug boat

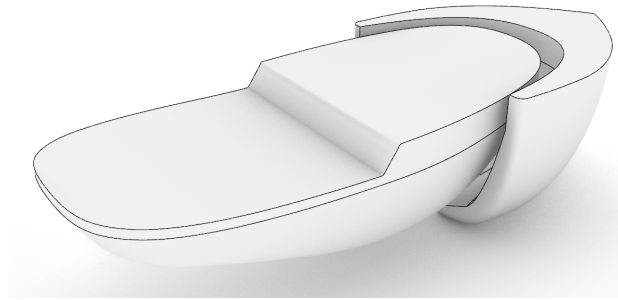

e) concept tug- icebreaker module

Figure 2. Pusher/tug with additional structure

2.1 Selected tug boat

The tug boat 2913, build by Damen Group in Galati shipyard, was chosen considering its great power for good towing capacity capabilities, power that can be used

for compensating the increased total resistance of the ship.

The main dimensions of the tug boat 2913 which were used for adapting the module are listed in Table 1, can be seen in Figure 3.



Figure 3. The 2913 Damen tug boat

Table 1. Main characteristics

Symbol - Name	Value
Loa - Length overall (m)	28.1
Lwl - Length on waterline (m)	27.8
D - Depth (m)	25.6
B - Breadth	12.6
T - Draft (m)	4.3
S - Span (mm)	550.0
Engine power (kW)	5,050.0
Bollard pull (t)	80.0

2.2 Module ice breaker main dimension

The icebreaker module design was done following the Det Norske Veritas Rules for the Classification of Ships Operating in Polar Waters and Icebreakers, for "Ships intended for navigation in ice-infested polar waters" with the application

"Summer/autumn operation in medium first-year ice which may include old ice inclusions".

This notation further returned the upper ice waterline angle and the buttock angle at upper ice waterline:

$$\alpha = 40^\circ$$

$$\gamma = 60^\circ$$

Through an iterative process, considering the icebreaking type, the obtained angles for the hull and the theoretical volume of the bow being less than 50% of the tug's volume, a series of dimensions were determined for the additional structure as is presented in Figure 4, 5 and Table 2.

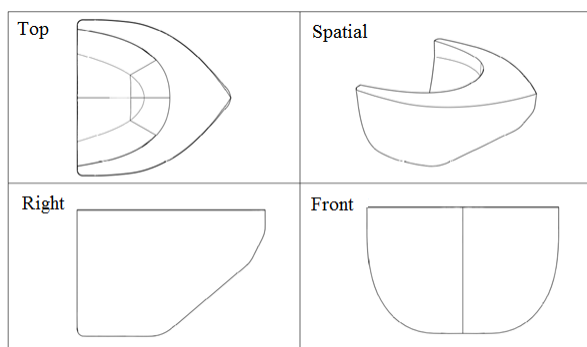

Figure 4. Module icebreaker shapes

Table 2. Module icebreaker main dimensions

Symbol - Name	Value
Loa - Length Overall (m)	13.90
Lwl - Length on waterline (m)	13.70
D - Depth (m)	9.37
B - Breadth (m)	14.00
T - Draft (m)	6.20
S - Span (mm)	550.00
Δ - Displacement (t)	375.00



Figure 5. Module structure's shape

3. Structural design

Due to the special conditions of navigation and operation, the resistance structure must strictly comply with DNV rules. Also, the bow structure of the tugboat must be reinforced with skeleton elements in the area where the icebreaker module is bolted. The resistance structure of the module was divided into zones depending on the efforts that occurred during the breaking of the ice. This operation was carried out because the structure of the module must not be oversized.

Considering the requirements for the icebreakers, the ice interaction area for a classic icebreaker ship has to be represented. The magnitude areas as described in the DNV rules are presented in Figure 6. As built shell expansion is presented in Figure 7.

In the following tables 3, 4 the ice belt extension is presented for both hull plating and for structure.

According to the DNV Rules [2], for a class notation ICE 1B, the extension of the ice belt is dependent of the type of structure. The extension for shell plating and stiffeners is shown in the below tables.

The ice pressure calculation has been performed according to Pt.6 Ch.6 Sec.2 [7.3]. The ice pressure is calculated for the bow area, for plating, stiffeners, web transverse frames and for ice stringers as defined in Table 5.

Based on Pt.6 Ch.6 Sec.2 [4.1.4], the acting pressure P , has been multiplied by a factor of 1.8 MPa. The loads applied for direct calculation are given below.

The acceptance criteria for the direct calculation are given in Pt.6 Ch.6 Sec.2 [4.1.4] and are dependent on the yield

strength of material and is not to be larger than $0.9 Re H$ for bending stresses.

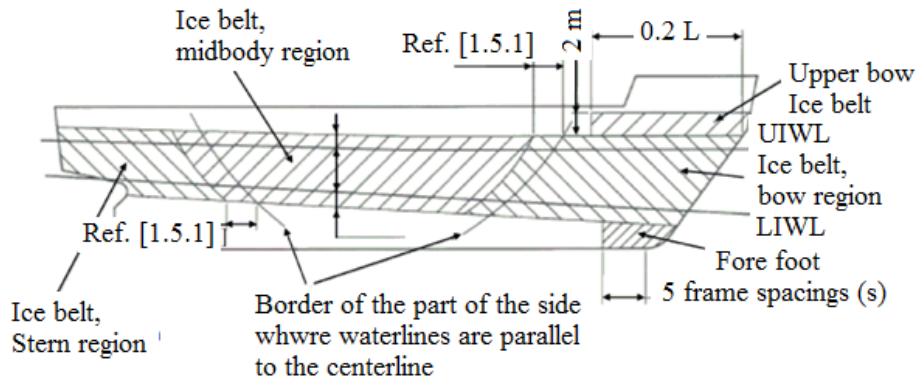

Figure 6. Ice area definition

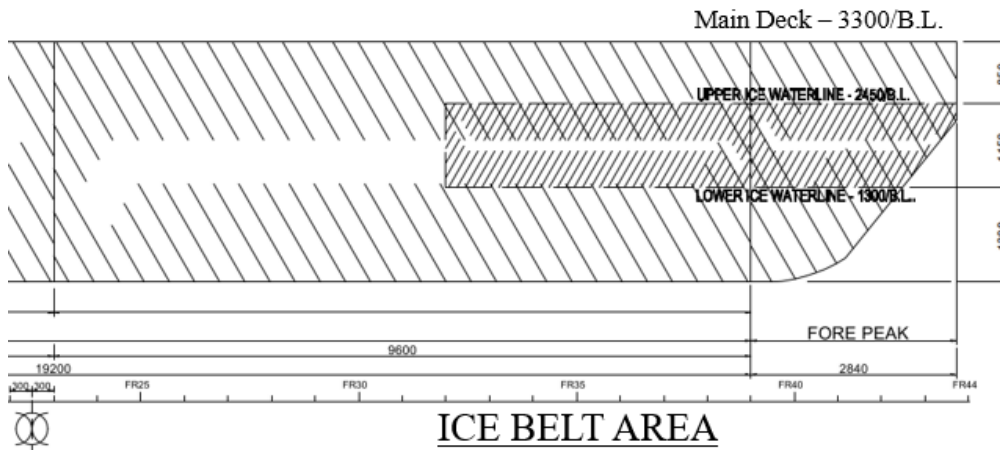

Figure 7. As built shell expansion - definition of ice belt area

The acceptance criteria for the direct calculation are given in Pt.6 Ch.6 Sec.2 [4.1.4] and are dependent on the yield strength of material and is not to be larger than $0.9 ReH$ for bending stress.

Following the DNV Rules for Classification of Ships and taking in consideration similar ship types examples, are presented in Table 7.

The functions of a structure are, mainly, receiving loads and transferring forces. In the ice breaking process, high displacements and deformations values can arise and lead to geometry and boundaries distortions. For the analysis of stress during ice interaction, the designed 3D model of the additional structure will be subdued to the Finite Element Method analysis.

Table 3. Extension of ice belt for plating

Ice class	Region	Above UIWL (m)	Below LIWL (m)
Ice (1A*)	Bow	0.600	1.200
	Midbody		1.000
	Stern		
Ice (1A)	Bow	0.500	0.900
	Midbody		0.750
	Stern		
Ice (1A) and Ice (1C)	Bow	0.400	0.700
	Midbody		0.600
	Stern		

Table 4. Extension of ice belt for stiffeners

Ice class	Region	Above UIWL (m)	Below UIWL (m)
Ice (1A*F), Ice (1A*)	Bow	1.200	To double bottom of below top of floors
	Midbody		2.000
	Stern		1.600
Ice (1A), (1B), (1C)	Bow	1.000	0.900
	Midbody		0.750
	Stern		

Table 5. Ice reinforced area – Loading definition

Structure	Type of framing	l_a
Shell	Transverse	Frame spacing
	Longitudinal	1.7* frame spacing
Frames	Transverse	Frame spacing
	Longitudinal	span of frame
Ice stringer		span of stringer
Web frame		2*web frame spacing

Table 6. Load definition for direct calculation for bow area

Structure	Pressure [MPa]	Multiplication factor	Total pressure [MPa]
Transverse stiffeners	1.40	1.80	2.520
Transverse web frames	0.70	1.80	1.260
Ice Stringers	0.49	1.80	0.882

Table 7. Plating and structure thicknesses

Element		Thickness [mm]
Plating	Bow	32
	BI icebelt	32
	BI lower	22
	BI bottom	16
Keel		30
Deck		18
Intermediary Decks		15
Transverse Bulkhead		10
Longitudinal Bulkhead		10
Web frames	Exterior Plating	T300x100x15
	Interior Plating	T250x100x
Simple frames	Exterior Plating	T150x100x15
	Interior Plating	T120x80x
Longitudinals		HP200x9
Deck girders		HP240x10
Transverse Bulkhead Stiffeners		HP240x10
Longitudinal Bulkhead Stiffeners		HP240x10

Considering the previously presented, the resistance structure of

the icebreaker mode presented in Figure 8 was designed.

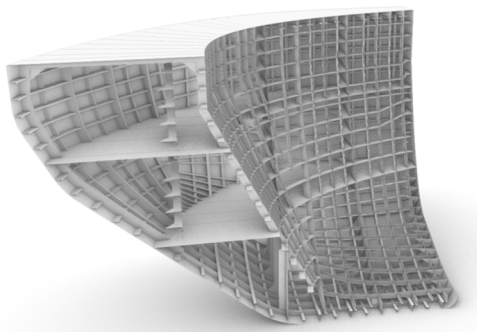

a) Starboard

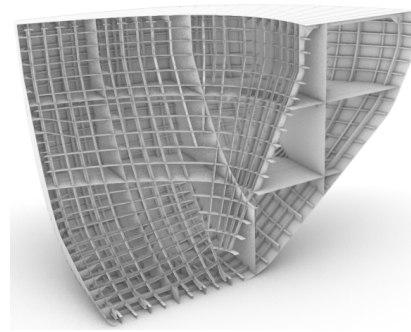

b) Port side

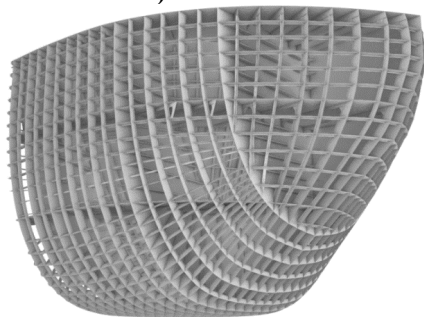

c) Inner shell hidden

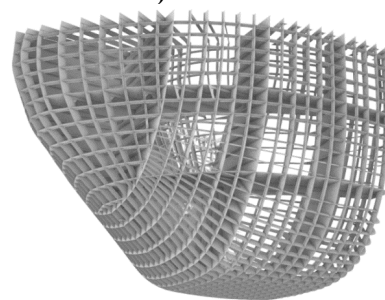

d) Isolated exterior frames

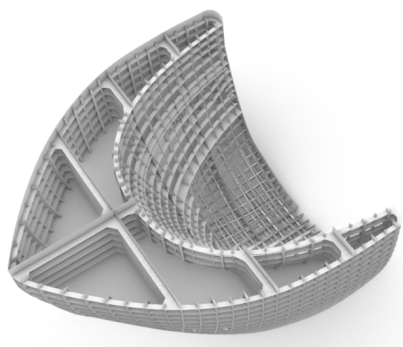

e) Deck and deck structure hidden

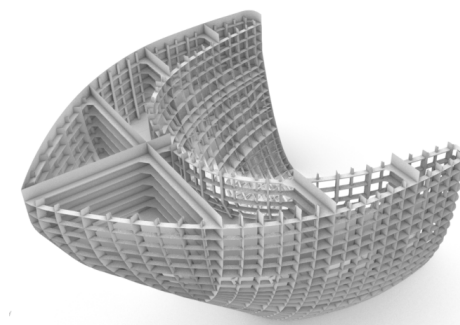

f) Shell and deck structure hidden

Figure 8. Isometric view of structure

4. Structural analysis

One of the most important steps in finite element modelling is obtaining a meshed model equivalent to the actual continuous structure and, therefore, achieving a finite number of degrees of freedom, for which the matrix operations can be defined.

The types of finite elements used for the structural idealization are beam isoperimetric (6 degree of freedom per node) and rectangular plate elements (3 degree of freedom per node)

4.1 Geometric model

The additional body structural requirements were initially designed as calculated. Specific structural situations required deviation from the class restrictions. Thus, personal contributions were brought to the 3D model of the icebreaking structure, such as: profile direction deviation for end to end connections, additional brackets for transverse and longitudinal bulkheads and also for deck stringers, particular distances and positions were modified according to different connections needed. For a simpler meshing process, all the surfaces were split according to intersections with any other surfaces.

All the structural modifications were accomplished using Rhinoceros software and all the elements were grouped on thickness layers for export in a format supported for the finite element analysis. The hull plates

were divided on thickness areas as well and separately exported. The format chosen was Parasolid type and the ten layers of structure were exported accordingly. The layer numbering was done corresponding to the thicknesses for an easier property and material assignment as shown in Table 8.

In table 9 is presented the weight of the icebreaker module.

4.2 Structure settings

4.2.1 Materials and properties

The material definition requires Poisson's Ratio, Young Modulus and density values, while the property setting chooses the previously created material and the element type. Since the entire model consists only of surfaces, the element type chosen was plate for all the elements. All the imported surfaces are presented in Figure 9.

**Figure 9.** Global structure – isometric view

Table 8. Element layers

Layer name	Elements on layer	
Layer8	Interm deck stiffeners	Brackets
Layer 9	Interior plating longitudinal	Exterior plating longitudinal
Layer10	Transv and long bulkheads	Trans and longit bulkhead stiffeners
Layer12	Interior and exterior web frames	Interior and exterior simple frames
Layer15	Intermediary decks	
Layer16	Bottom plating	Interior plating
Layer18	Main deck	
Layer22	Bow intermediate lower plating	
Layer30	Keel	
Layer32	Bow plating area	Bow intermediate ice belt plating

Table 9. Masses structure and weight

Elements of the same thickness	Thickness [mm]	Area [m2]	Mass [kg]
Intermediary deck stiffeners, Brackets	8	33.6	2,108.7
Interior and exterior plating longitudinals	9	231.8	16,376.2
Transverse and longitudinal bulkheads, stiffeners and main deck stiffeners	10	247.1	19,395.1
Interior and exterior web frames and simple frames	12	235.6	22,190.8
Intermediary decks	15	138.1	16,264.7
Bottom plating and interior plating	16	231.8	29,108.4
Main deck	18	68.0	9,605.6
Bow intermediate lower plating	22	62.4	10,777.8
Keel	30	7.4	1,733.2
Bow plating area, bow interm ice belt plating	32	279.9	70,318.6
Total mass			197,879.1

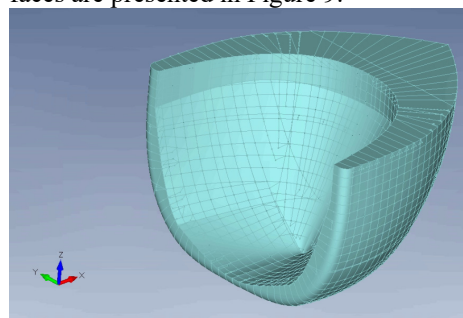
For the mesh control, the size chosen value of 150, whereas for the geometry mesh, also the surface option was selected and the chosen element type was triangular for the respective property needed with the free mesh option selected. The element size

value was chosen higher for an easier and faster analysis and overall process. A total of 204161 elements resulted.

The mesh for the icebreaker module is presented in Figure 10. The mesh was done as was presented above for each type of

layer. This helps to later identify more easily the deformations and stresses that appear as a result of the stress in the various component elements of the module structure.

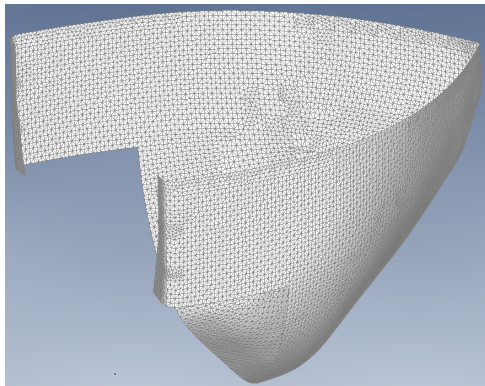

a) Exterior shell

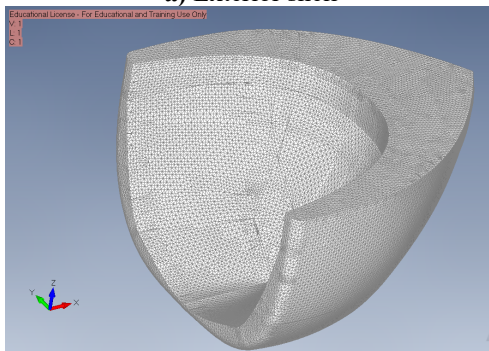

b) general mesh overview
Figure 10 Module area mesh

4.2.2 Constraints and loads definition

Since the additional structure is attached to the tug's body with the bolt – connection element system, the system's position was needed for the constraints definition. Thus, a new layer was created and the area in which the bolts are located was targeted for constraining. In Figure 11 a) and b) the bolt – connection element system is presented in a display of the module structure and a section of the tug's bow for a better understanding, while in Figure 12 a section view of the connecting system is presented.

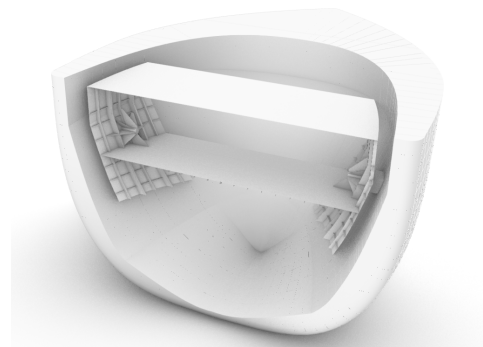

a)

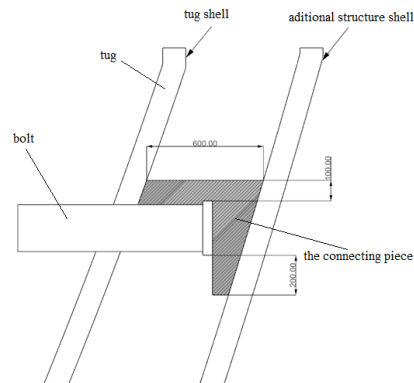

b)

Figure 11

In this manner the surfaces on which the connection element is attached were depicted for which the x and z direction displacement and rotation were blocked and as well the displacement on y direction. In Figure 12 a) an isometric view of the interior shell, on which the constraints are applied, is presented. In Figure 12 b) is presented the applied pressure (hydrostatic and with ice) on the surfaces is shown.

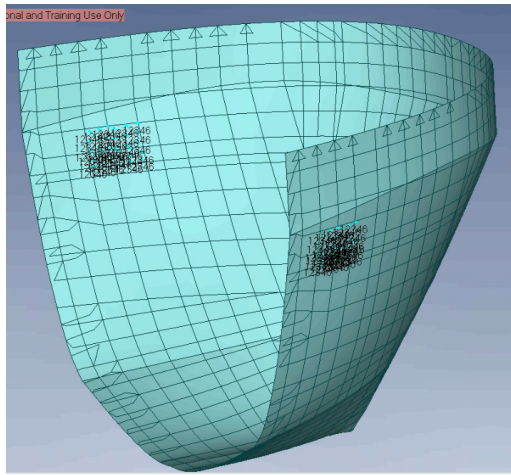

Figure 12.a Constraints

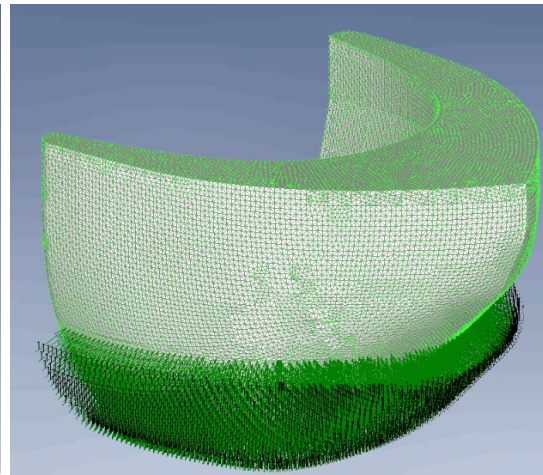

Figure 12.b Loads

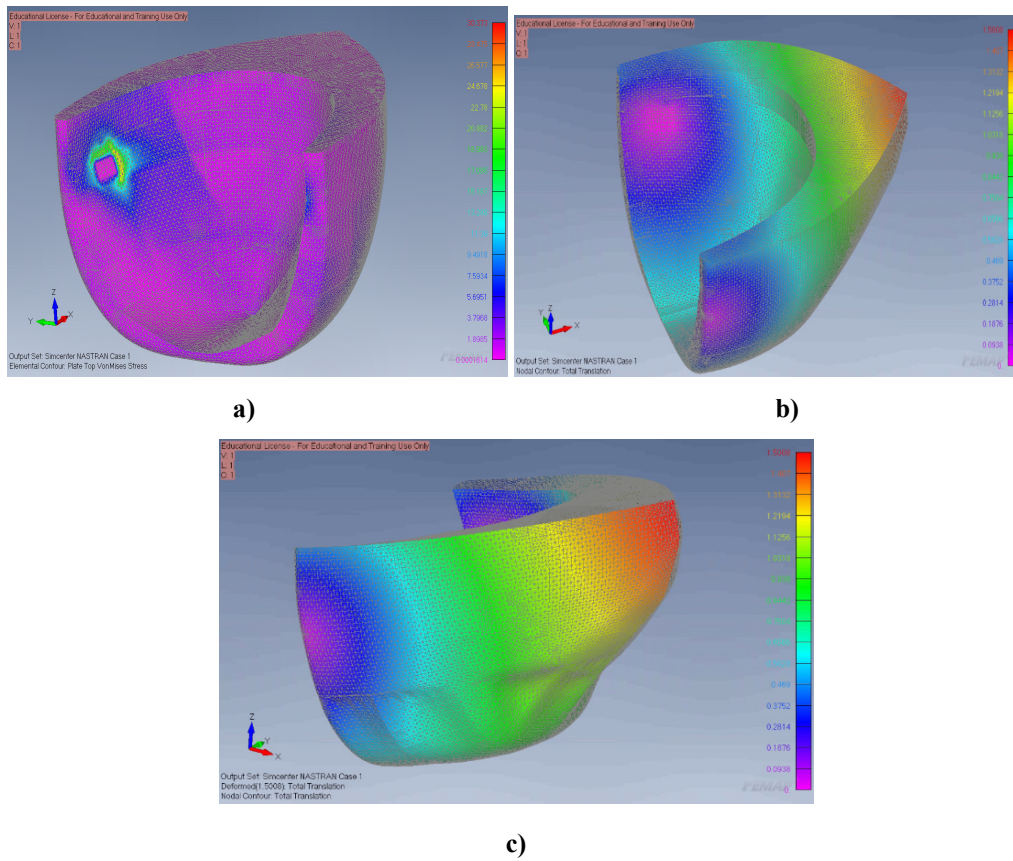

Figure 13 Stress and strain

5. Numerical results

The results obtained for the total translation case with VonMises Stress contour is presented in Figures 13 a) and the strain 13 b, c).

The highest value of total stress approximative 34 MPa is around the bolt junction between module and tug boat (the highest values represented in red color).

For the total translation post data, the obtained results, presented in Figures 13 b) and 13 c), rise to a value of 1.5 mm.

As can be seen from figures 13, these deformations and stresses do not appear in the contact area of the ice breaker module shell, which indicates that this area was designed respecting the class requirements regarding the dimensions of the resistance elements.

6. CONCLUDING REMARKS

As a first finding, the weight of the additional structure has increased by updating it with personal contributions in order to obtain an analyzable 3D model for the finite element calculus. The weight value has raised with 16 tones, signifying an increase of 10% and representing 73.4% of the tug's mass.

The division of the surfaces, using the Rhinoceros software, highly reduced the time and simplified the meshing process, despite obtaining a considerable number of lower quality elements. This stage being the most time consuming, it can be improved by further modifying the structure and finding different connection solutions that would not return such small or distorted surfaces.

As it can be recognized through the stress variation, the values obtained are within the allowable limits for the AH36 steel. The deformations for both stress and strain suggest a better meshing or different type of element choice could improve the results.

Also, since the icebreaking loads data is unknown, the envisaged computational efforts

were increased by 50%, thus assuring a safety margin. Therefore, the loads applied on the additional icebreaking structure, from published data, are complying with the previously mentioned percentage.

Considering the obtained results, it can be inferred that the chosen loads values do not lead to stresses over the allowable conventional limits of yield strength of the usual naval AH36 steel, being 355MPa.

Acknowledgements

The present research has been supported by the University Dunarea de Jos of Galati.

REFERENCES

- [1]. Pentti Kujala, Liangliang Lu – Marine Design XIII, Vol. 2
- [2]. Stephen John Jones – A history of ice-breaking ships
- [3]. Leonard Domnişoru – Metoda elementului finit în construcția navală.
- [4]. Costel Iulian Mocanu – Rezistența materialelor
- [5]. DNVGL Rules for Classification – Part 6 Chapter 6 Cold climate
- [6]. Paulling JR. The analysis of complex ship structures by the finite element technique

Paper received on November 1st, 2022