



Geological evolution process, mechanism, and application of protective layer in semi-coal and rock face

Xiaoping Xie^{1,2}, Xinqiu Fang^{1*}, Minfu Liang^{1,3}, Dechun Ai²

¹State Key Laboratory of Coal Resources and Safe Mining, China University of Mining and Technology, Xuzhou 221116, China

²College of Mining and Civil Engineering, Liupanshui Normal University, Liupanshui 553004, China

³School of Management, China University of Mining and Technology, Xuzhou 221116, China

*Corresponding author: 264580414@qq.com

ABSTRACT

Under the influence of geological structure, the surrounding rock of semi-coal seam is easy to be loose and fractured, and the repairing rate is high. Therefore, it is of great theoretical and practical significance to study semi-coal seam mining's mechanism and control technology. In this paper, the geological evolution principle of the semi-coal seam is analyzed theoretically. The mechanic's relationship between the mining height of the semi-coal face and the lower coal seam's pressure relief is interpreted. The mechanism of eliminating bad blind areas in non-pillar mining of upper protective seam is analyzed. Through numerical simulation analysis, it is concluded that the expansion deformation rate of a protective layer increases linearly with the increase of mining thickness of the protective layer, and the width of undesirable blind zone of coal seam increases linearly with the rise of protective layer thickness. This paper puts forward the technology of non-pillar mining in the protective seam's semi-coal and rock face. Field industrial test results show that the technology achieves the overall pressure relief and reflection reduction of low permeability and high gas coal seams. The underlying 3 + 4 protective layer achieves the general pressure relief and reflection reduction of low permeability and high gas coal seams. Coalbed methane can be pre-drained up to 18 m³/min with a concentration of 90%.

Keywords: Semi-coal rock; Geological Evolution; Non-coal pillar; Distressed blind-zone; Gas extraction.

Proceso de evolución geológica, mecanismo y aplicación de capa de protección en minería de semicarbón y en pared de roca

RESUMEN

Bajo la influencia de la estructura geológica, la roca que rodea la veta de semicarbón puede soltarse y fracturarse, y el índice de reparación es alto. Es de gran importancia teórica y práctica estudiar el mecanismo de minería de la veta de semicarbón y la tecnología de control. En este artículo el principio de la evolución geológica de la veta de semicarbón se analiza teóricamente. Además, se interpreta la relación mecánica entre el peso de la minería en la pared y el alivio en la presión de la parte baja de la veta. También se analiza el mecanismo de eliminar las áreas ciegas en la minería sin pilares de la veta superior protectora. A través del análisis de simulación numérica se concluye que el índice de deformación por expansión de una capa de protección se incrementa linealmente con el aumento del grosor de la capa de protección, y el ancho de la indeseable zona ciega en la veta de carbón se incrementa linealmente también con el incremento en el grosor de la capa de protección. Este trabajo ofrece una tecnología en minería sin pilar de la capa de protección en la veta de semicarbón y en la pared de la roca. Los resultados de evaluaciones de campo industriales muestran que esta tecnología logra un alivio general en la presión y en la reducción del reflejo en vetas de baja permeabilidad y de carbón con alto índice de gas. La capa de protección 3 + 4 logra el alivio en la presión general y en la reducción del reflejo en vetas de baja permeabilidad y de carbón con alto índice de gas. El metano en capas de carbón puede ser drenado previamente en hasta 18 m³/min con una concentración del 90 por ciento.

Palabras clave: roca de semicarbón; evolución geológica; minería sin pilar; peligros de la zona ciega; extracción de gas.

Record

Manuscript received: 12/03/2019

Accepted for publication: 20/09/2020

How to cite item

Xie, X., Fang, X., Liang, M., & Ai, D. (2020). Geological evolution process, mechanism, and application of protective layer in semi-coal and rock face. *Earth Sciences Research Journal*, 24(4), 499-506. DOI: <https://doi.org/10.15446/esrj.v24n4.91378>

Introduction

When the roadway excavation section has both rock and coal seam, and when the coal seam occupies 1/5 to 4/5 of the area of the excavation face, it is called semi-coal-rock mining working seam, which generally exists in thin coal seam conditions. Taking China as an example, the reserves of unexploited semi-coal and rock mining working strata are about 6.150 billion tons, accounting for 20.4% of the total recoverable reserves. In some areas, the proportion of semi-coal seam reserves is larger, such as Sichuan Province accounts for about 60%, Shandong Province for about 54%, Heilongjiang Province for about 51%, Guizhou Province for about 37% (Yuan, 2008a; Zhou et al., 2016). Other coal-producing provinces, such as Henan, Shanxi, Inner Mongolia, Hebei and Jilin, also have rich thin seam resources. With the continuous reduction of coal resources, semi-coal and rock mining will be a problem faced by China and even the world coal mining industry.

Semi-coal-rock working face has small space of movement, difficult worker operation, complex mining method, easy to occur safety accidents, low economic benefits. Semi-coal-rock working face is mostly semi-coal-rock roadway, which has low tunneling rate, high tunneling cost, tight mining replacement and low mining efficiency. It was shown as Figure 1.

In this paper, the principle of geological evolution of semi-coal seam is analyzed theoretically, and the technical measures of linear increase of expansion deformation rate of protective seam with the increase of mining thickness of protective seam are put forward.

Seam Semi-coal-rock Mechanism

Structural analysis

Semi-coal and rock transportation roadway are arranged in mud-stone and coal seam. The lithology of two sides, roof and floor is relatively fragile, the deformation parameters are relatively large, and the tensile and shear failure strength is relatively small (Wu et al., 2004). Under the influence of mining, the

surrounding rock of two sides, roof and floor is seriously damaged, the scope of loosening zone is relatively large, and the bearing capacity of surrounding rock is relatively low. According to the analysis of consolidation theory, the length of roof bolt and side bolt is insufficient in the original supporting scheme, the anchorage section of bolt cannot be anchored in the original rock stress zone, and the anchorage force is insufficient, which leads to the insufficient strength of roof and two sides of roadway. The diameters of top anchor and side anchor are small, the tensile strength and prestressing force are not enough, the extrusion strength of anchor end to destroyed surrounding rock, coal seam and mud-stone is small, the secondary bearing area cannot be formed, and the mechanical properties of anchor solid cannot be improved. The deformation of surrounding rock cannot be controlled in time, and the roof pressure can be transferred to both sides, resulting in larger stress, horizontal stress and vertical stress in both sides. The force is almost vertical, so serious deformation, roof subsidence and floor heave appear on both sides of the roadway.

In order to study the maximum damage range of roof strata and side wall of semi-coal-rock roadway, theoretical analysis is carried out according to that all roadways are coal seams (Yuan, 2008b). Because the thickness of carbonaceous mud-stone layer on the roof of roadway varies greatly, its caving shape is arch. According to the theory of Pressure-free Arch, as shown in Figure 2.

Semi-coal and rock transportation roadway is a typical soft rock mining roadway, and its surrounding rock deformation characteristics are as follows: (a) the surrounding rock deformation is intense and large, the convergence rate of roadway section is as high as 38% during excavation, and the deformation has rheological characteristics and lasts a long time; (b) the degree of surrounding rock fragmentation gradually weakens from shallow to deep, and its damage scope exceeds the anchorage range of the anchor, resulting in the failure of the anchor; (c) the surrounding rock loosening and breaking; The rapid development and serious destruction of the bad scope result in the reduction of anchorage effect, failure of anchorage system and failure of supporting bearing structure, which further aggravates the development of



Figure 1. Semi-coal-rock working face

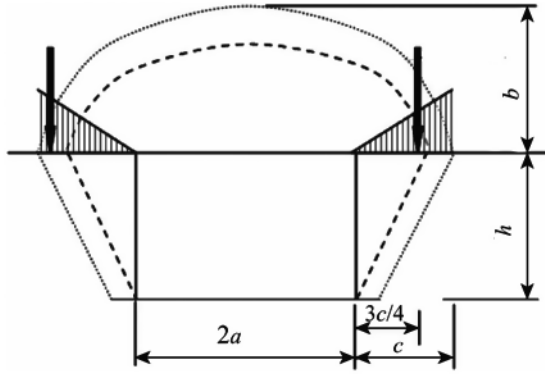

Figure 2. Calculating model of semi-coal and rock structure

surrounding rock loosening and failure to its due support effect. Fourthly, the phenomenon of two sides of roadway is widespread, and the phenomenon of arch roof and arch waist separation layer falling off is widespread, which leads to the failure of external anchorage point of some bolts, which also leads to the failure of external anchorage point of some bolts. It is an important reason for the reduction or failure of anchorage effect. In conclusion, the failure mode of surrounding rock of semi-coal and rock transportation roadway belongs to the typical large deformation failure mode of soft rock rheology. The failure mechanism of support is as follows: under the condition of high in-situ stress, the scope of loosening and failure of weak surrounding rock expands rapidly, and its rheological action causes the surrounding rock of roadway to break and the deformation continues to increase, resulting in the failure of bolt-mesh combined support structure, which leads to the loss of bearing capacity of surrounding rock-support bearing structure.

Mathematical model

In view of the high-efficiency mining that is hard to exploit the resource of extremely thin coal seams, the idea of small fully-mechanized mining in the semi-coal rock working face is proposed, and the mining height is increased by breaking the weak roof or floor of an extremely thin coal seam to increase mining height in order to install small fully-mechanized mining equipment and improve the pressure relief effect of the coal seam group at the below part. After the semi-coal rock working face is mined, the load of overlying strata in goaf is transferred to the front of coal wall forming an abutment pressure, and the coal wall is in a plastic or fracture state within a certain depth (Zhou et al., 2015; Cheng et al., 2012). Usually, the front of coal wall is divided into two zones in the abutment pressure: plastic zone and elastic zone. According to the limit equilibrium condition, the abutment pressure in the plastic zone is distributed:

$$\sigma_y = R_c e^{\frac{2f\xi}{h+\Delta h}x} \tag{1}$$

In this formula, σ_y is the lead abutment pressure, Mpa; R_c is the residual strength of the coal wall, Mpa; f is the friction coefficient of the layer, in the $f=\tan\phi_1$, ϕ_1 stands for the friction angle between the roof and floor of the coal seam and the coal seam, ϕ ; $\xi=(1+\sin\phi)/(1-\sin\phi)$, ϕ is the internal friction angle of the coal, ϕ ; h is the thickness of the extremely thin seam, m; Δh is the thickness of the broken rock, m; the abutment pressure distribution in the elastic zone is a negative exponential curve,:

$$\sigma_y = \gamma H \left[1 + \Delta k e^{-\delta(x-x_0)} \right] \tag{2}$$

$$x_0 = \frac{h + \Delta h}{2f\xi} \ln \left(\frac{k\gamma H}{R_c} \right) \tag{3}$$

In the formula: γ is the coal bed bulk density, N/m³; H is the depth of coal seam; Δk is the maximum concentrated stress increment coefficient, $\Delta k=k-1$; δ is the lead abutment pressure attenuation coefficient; x_0 is the width in the plastic zone, m; x is the distance from the coal seam,.

From the formulas 1, 2, and 3 it can be known that the plastic zone width x_0 in the semi-coal rock working face is proportional to the coal mining height ($h+\Delta h$) and the width of the plastic zone of the extremely thin coal seam is smaller. Figure 3 shows the distribution rules of abutment pressure of working face. The Curves in the figure meet the distribution formula of abutment pressure in plastic zone (1), and curves satisfy distribution formula of abutment pressure in elastic zone (2).

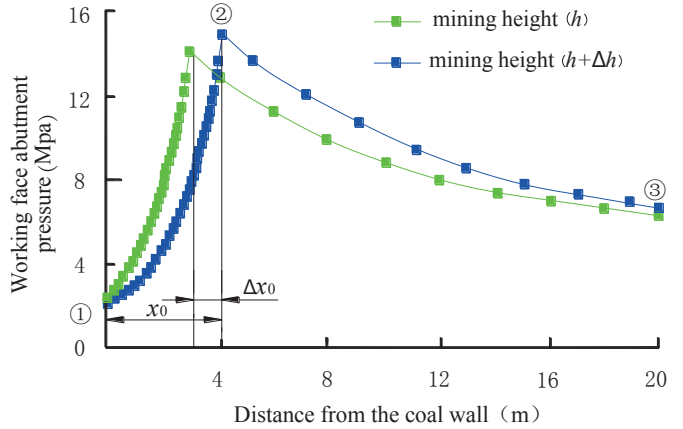

Figure 3. The distribution rules of abutment pressure of extremely thin coal seam during work

According to the formula (3), the increase of width in plastic zone of semi-coal rock working face can be calculated as:

$$\Delta x_0 = \frac{\Delta h}{2f\xi} \ln \left(\frac{k\gamma H}{R_c} \right) \tag{4}$$

According to the relationship between the lead abutment pressure of the working face and the destruction of the underlying coal and rock seams, a structure of the plastic destruction zone of the underlying coal and rock along the advanced direction of the coal seam is established.

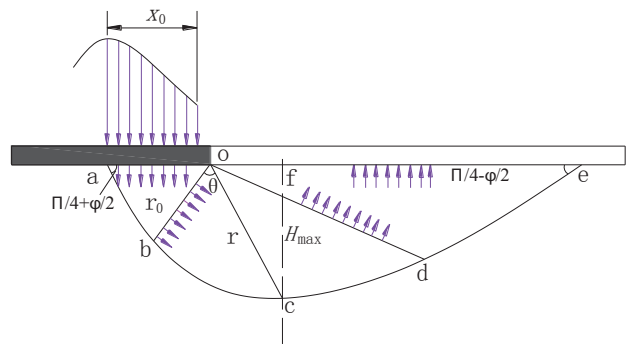

Figure 4. Section of plastic destruction zone of overlying coal strata

According to the geometrical dimensions of the ultimate plastic destruction zone shown in Figure 4, the maximum destruction depth of the floor destruction zone under the action of the extreme lead abutment pressure can be preliminarily determined :

$$H_{max} = \frac{x_0 \cos \phi}{2 \cos(\pi/4 + \phi/2)} e^{(\pi/4 + \phi/2) \tan \phi} \tag{5}$$

In this formula: H_{max} is the maximum destruction depth of the coal seam floor; x_0 is the width of the plastic support area in front of the coal wall; ϕ is the internal friction angle.

According to the formulas 3 and 5, it can be known that after the mining of the semi-coal rock working face, the maximum destruction depth of the floor is proportional to the width x_0 of the support pressure in plastic zone in front of the coal wall, it is equal to the mining height of the semi-coal rock working face ($h+\Delta h$).

Evolution of Semi-coal Seam

Semi-coal and rock from the beginning of tunneling to withstand two mining face impact and roadway retention stage roof rotation subsidence (Li, 2014), long service time, surrounding rock presents large deformation characteristics, surrounding rock pre-deformation directly related to the later deformation (Li et al., 2011; Liu et al., 2009), showing a typical evolution characteristics. Obtaining the displacement, strain and fracture evolution law of surrounding rock from tunneling to the end of secondary mining is of great significance to reveal the deformation mechanism.

Evolutionary simulator

Restricted by the field testing environment and testing level, there are some difficulties in measuring the deformation evolution law of surrounding rock of semi-coal and rock. Laboratory physical simulation can well realize the observation of deformation of semi-coal and rock. The testing environment is good and the testing accuracy is high (Liu et al., 2011). In this paper, the physical simulation of semi-coal and rock is carried out by using the self-developed two-way and four-side loading test device, and the deformation of semi-coal and rock is observed.

The commonly used plane experimental devices are mostly used to simulate stope advancing, observe roof caving pattern, and simulate vertical stress by adding counterweight (Liu et al., 2013). There is no active load on both sides and floor, which results in great difference between boundary conditions and original rock stress field, and the credibility of simulation results is reduced (Ma et al., 2007). In order to better study the surrounding rock deformation of gob-side retaining roadway, a two-way and four-sided loading test device is developed, which overcomes the problem that the three-dimensional simulation test device cannot advance step by step and continuously, and solves the problem that the common plane simulation cannot exert high stress on top, bottom, left and right.

The design of simulation device is controlled by different oil system, which can realize unequal pressure loading on all sides. It can simulate the process of driving, advance effect of primary mining, advance effect of retaining roadway and secondary mining under the corresponding real in-situ stress state (Chen et al., 2003). It is innovative in the experimental study of Retaining Roadway along gob at home and abroad. The overall size of the test device is 4.5 x 0.5 x 4.5 m, and the effective test size is 4.0 x 2.5 x 0.5 m.

The parameters of the simulator are shown in Figure 5 and Table 1.

The numerical simulation of mechanical parameters of the coal mine is shown on Table 1.

Process recording

The simulation evolution process is to simulate the advance effects of gob-side entry retaining, primary mining, retaining and secondary mining according to the way of "excavation roadway-right boundary-middle mining,



Figure 5. Semi-coal-rock working face

filling body-left boundary-middle mining". The experimental device is a plane simulation device.

(a) Under the original rock stress state, the surrounding rock stress is redistributed when the roadway is excavated according to the design size (He et al., 2017). The existence of roadway space makes the floor of roadway change from three-dimensional stress state to two-dimensional stress state, and pressure relief occurs. This simulation process is the same as the actual situation.

(b) After the excavation of the right coal seam, the advance abutment pressure of the mining face acts on the stress superposition of the surrounding rock of the roadway and the surrounding rock during the excavation, which increases the failure depth of the surrounding rock, the peak stress concentration factor and the influence range. The stress state of the surrounding rock on the right side of the roadway is the same as that in the field (Jiang et al., 2013). The stress of the surrounding rock on the left side of the roadway is the superposition of the mining stress and the lateral pressure of the surrounding rock, slightly different from that in the field. Different.

(c) The filling body is placed immediately after the mining of the right working face is completed, and the simulation enters the stage of retaining roadway. In production, the most severe deformation stage of surrounding rock in gob-side retaining roadway is the rotary subsidence of the basic roof above the filling body. In simulation, after filling body is placed, the roof will not immediately rotate subsidence (Khademalhosseiny et al., 2017). With the generation, development, expansion and penetration of cracks, the stress will seek to rebalance, the basic roof will rotate subsidence, and the overlying strata load will act on the floor through the filling body. The process can well simulate the deformation characteristics of surrounding rock during the stable period of retaining roadway.

(d) After the mining of the left side face, the advance abutment pressure and the surrounding rock stress field after the stability of the retained roadway are superimposed (Rosa et al., 2017). The process of the left side of the roadway is the same as that of the field, and the stress field of the right side of the roadway is slightly different from the actual situation of the field.

The feasibility of the simulation scheme is discussed in stages below which shown as Figure 6.

Evolution simulation result

In order to study the relationship between the pressure relief effect of udder protected layer and the different heights of semi-coal rock working face, four simulation schemes were designed: mining height 0.5 m, mining height 1.5 m, mining height 2.5 m, and mining height 3.5 m. In the numerical calculation

Table 1. Mechanics parameters of the coal-rock joints

Lithology	Normal stiffness/GPa	Tangential stiffness/GPa	Cohesive force/MPa	Friction angle /°	Tensile strength/MPa
Coal seam	0.8	0.4	0	4	0
Medium sandstone	0.5	0.3	0	6	0
Fine-sandstone	0.4	0.2	0	7	0
Mudstone	0.6	0.3	0	5	0
Siltstone	0.5	0.5	0	7	0
Sandy mudstone	0.7	0.4	0	6	0

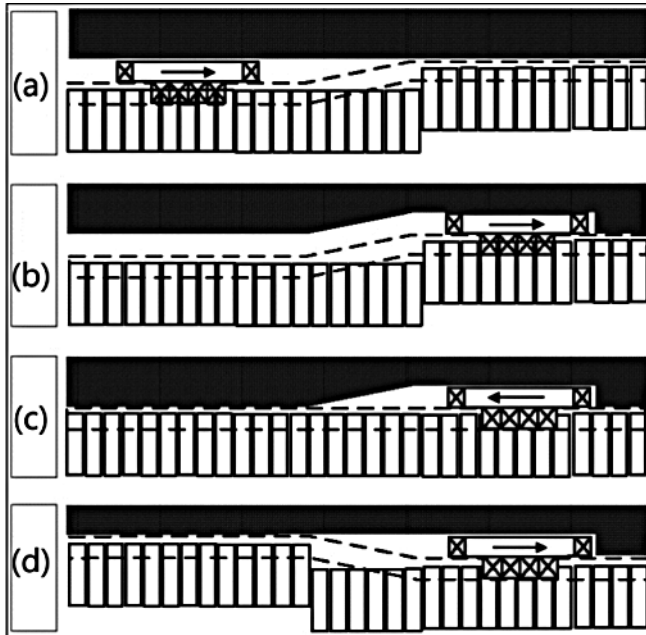

Figure 6. The feasibility of the simulation

model, the observation line is arranged in the lowest No. 5 protected coal seam, and the starting point of model excavation is at 50 m. When the working face is mined 150 m in an inclined direction, the expansion deformation rate change features of No. 5 are shown in Figure 7.

Engineering Application

Overall design

The engineering background is as follows: the coal mine uses +400 m north wing main roadway as the preparing roadway arrangement for inclined

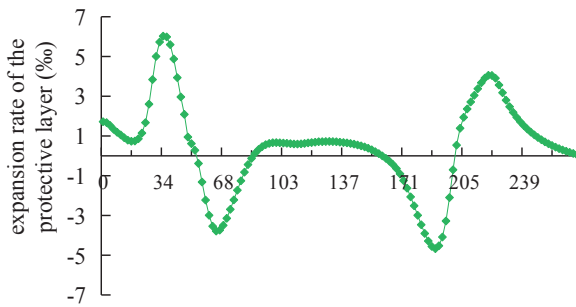

(a) Mining height 0.5 m

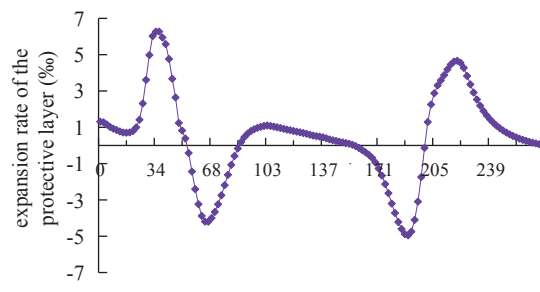

(b) Mining height 1.5 m

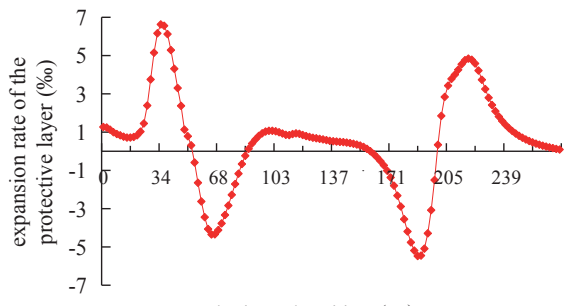

(c) Mining height 2.5 m

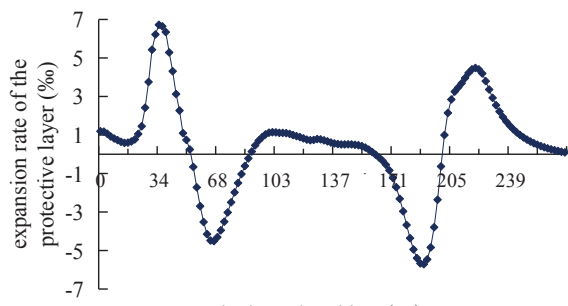

(d) Mining height 3.5 m

Figure 7. Expansion deformation rate curve

long-wall working face of small fully mechanized mining and 22201 working face is the first working face of the protective layer in the No.2 extremely thin coal seam of north second mining area. The slope length of designing the working face is 150 m, the length of the propulsion is about 1538 m, and the elevation of the working surface is +396 m~+486 m. The designed semi-coal rock working face is 1.5 m in height, adopting long-wall retreat mining method. The working face is mined without coal pillar of gob-side entry retaining, and after the 22202 working face roadway is mined, a Y-type ventilation system is formed: the 22201 auxiliary haulage roadway and the machine-rail unification roadway enter the wind, and the dirty wind passes through the 22201 gob-side entry retaining, 22202 open-off cut and rail roadway, it's as shown in Figure 8.

There are mainly the following problems in tunneling of semi-coal and rock face: first, poor shaping and surrounding of working face Rock failure and over-excavation are serious, especially in soft and broken strata (Cheng et al., 2003). It causes a lot of waste of supporting materials and poor safety conditions

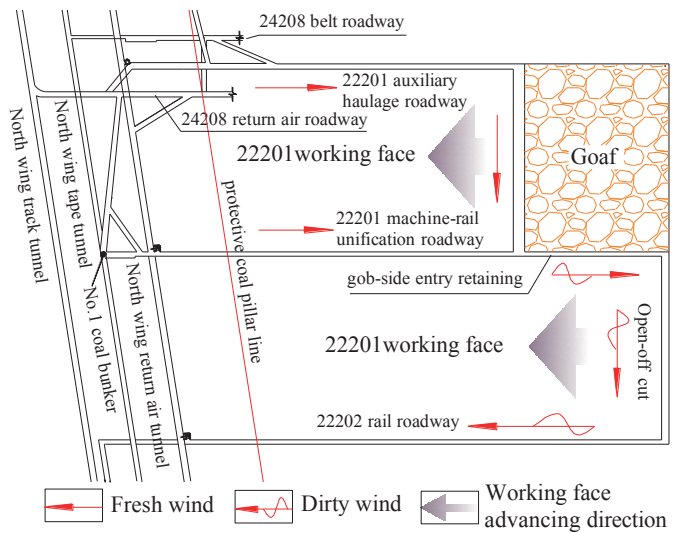

Figure 8. Layout of the 22201 working face of semi-coal rock

for head-on construction. Second, the half-coal and rock excavation speed is slow, which seriously affects the construction and arrangement of follow-up projects. Thirdly, rock loading and transportation are difficult because of inclination downhill; fourthly, water inrush control in working face also needs to take up a certain cycle time, which affects the driving speed of working face. At the same time, the rock stratum tends to be unstable due to the softening effect of water on rock, and the roadway is difficult to support. Secondly, coal and rock are transported separately, the regular circulation organization is complex, and the degree of parallel operation is low. Slow excavation speed has seriously affected the mining replacement relationship of mining face. The main reasons are as follows: first, the existing blasting technology is backward, which is not conducive to the formation of roadways; second, the support technology and support parameters are inadequate; third, the working line is not compatible with the site construction conditions; fourth, the construction technology, the layout of working face and the selection of labor organization forms, as well as the inadequate management system (Abubakary et al., 2015).



Figure 9. The 22201 working face on-site picture

Application method

On the site, the 22201 semi-coal rock and small fully mechanized working face of the typical coal mine is shown in Figure 9.

During the observation period from January 6 to July 22, the working face was promoted to 602.6 m and a total of 1,812,020 tons of coal was mined. From January 6 to February 27, the progress of the initial mining phase on the working face was slow. In 50 days, the working face completed a total advance of 113.2 m, and the average daily advance was 2.26 m, and the mining efficiency was low; from February 27th to July 22, the speed of advancement has improved, with an average of 3.05 m per day.

From the actual coal mining results, we can see that the equipment arranged in the working face and in the mining lanes meet the production requirements, and the semi-coal rock working face basically achieves safe and efficient mining.

Experimental Results and Analysis

Experimental results

(a) Overall pressure relief analysis of non-coal Pillar in Protective Layer: Coal seam deformation and stress change in the protected layer are the key to investigate the pressure relief effect of coal and rock below the remaining coal pillars and non-coal pillar (Bustin & Clarkson, 1998). The observation lines are arranged in the No.3+4 protected layer under the numerical calculation model. When working height of 22201 and 22202 working face is 1.5 m, the starting point of model excavation is at the coordinate of 40 m. After the length of two working faces is continuously mined in the direction of inclination of 150 m, non-coal pillars are left between the two working face interfaces and the width of the pillar of the section is left separately. For 20 m, 30 m, and 40 m, the expansion rate of the protected coal seam is shown in Figure 10 and Figure 11.

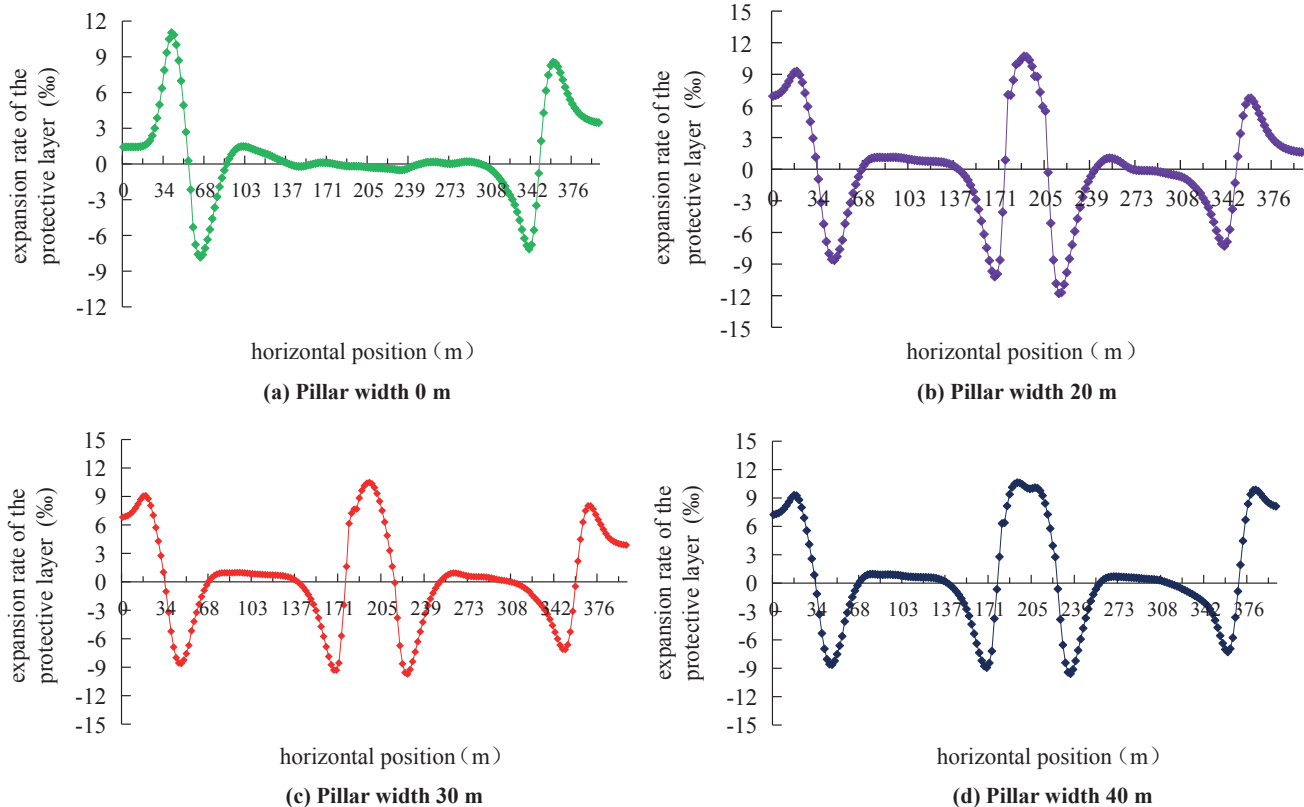

Figure 10. The expansion deformation rate curve

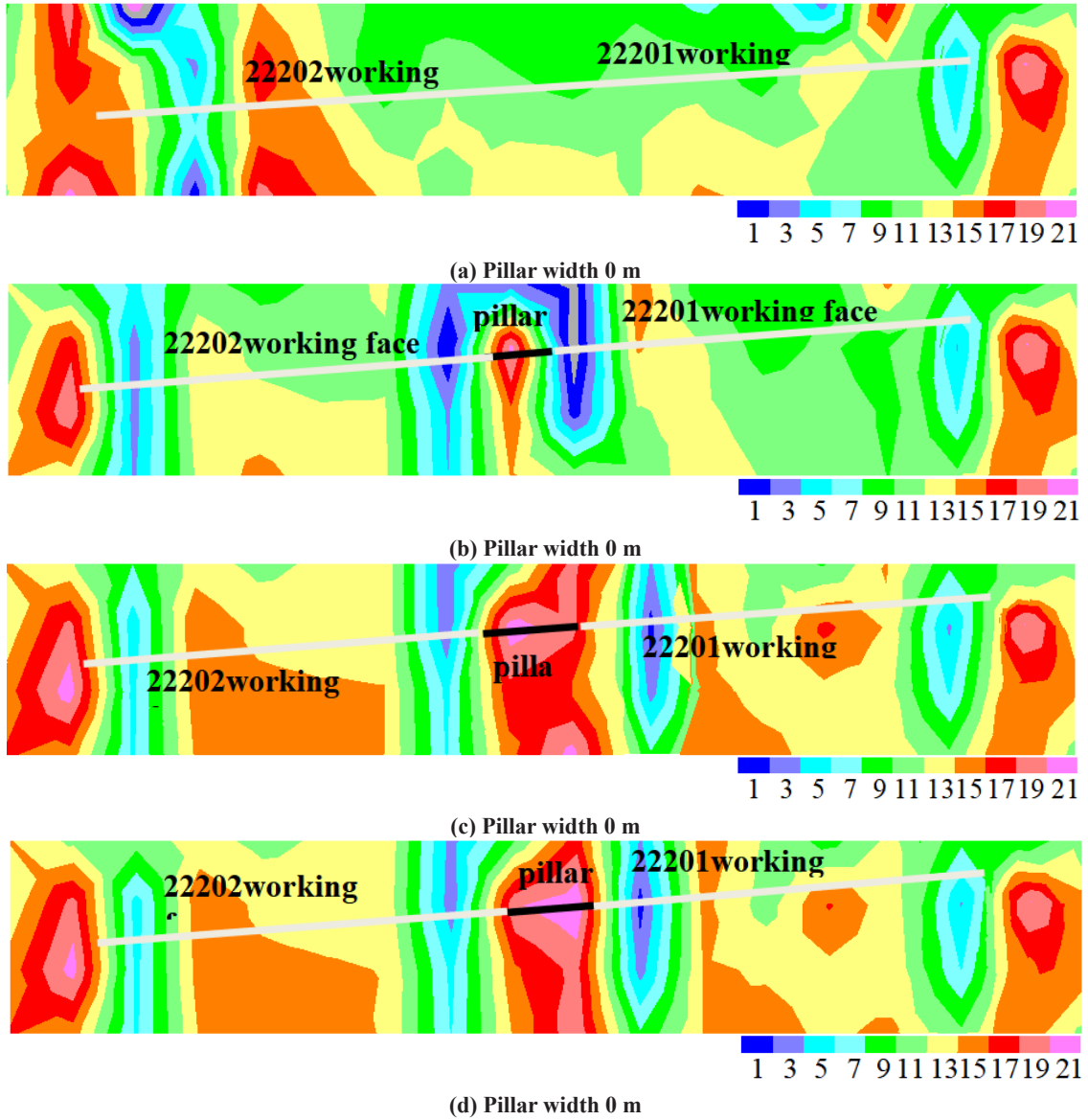

Figure 11. Vertical stress cloud picture of the working face of semi-coal rock with different pillar widths

Analysis

From the analysis of Figure 9, it can be seen that as the width of the upper coal pillar decreases, the expansion rate of the protected coal seam below the pillar that is less than 3% increasingly decreasing, which is the range of the distressed blind-zone. When the width of the section coal pillars is 40 m, 30 m, 20 m, and 0 m respectively, the inclination width of the No.3+4 coal seam below the coal pillar is less than 3%, which is 64.3 m, 52.2 m, 44.2 m, and 0 m, respectively. When non-coal pillars are used, the distressed blind-zone in the protected layer below the pillars are eliminated.

By establishing a rectangular coordinate system, the four simulation schemes with different widths of the coal pillars correspond to the width of the distressed blind-zone of the protected layer make four coordinate points, and then make the fitting straight line of four coordinate points. The analysis shows that the fitting linear equation is $y = 17.09x - 10.05$, and the fitting $R^2 = 0.8968$, that is, the width of the blind zone of the pressure relief of protected coal increases with the increase of the pillar width of the protective layer, which is roughly in line with the linear growth law of the fitted line (Chen et al., 2016).

From the analysis of Figure 11, it can be known that when the upper coal pillar is left in the upper protective layer, stress concentration occurs in the protected layer is under the coal pillar, and with the decrease of the width of

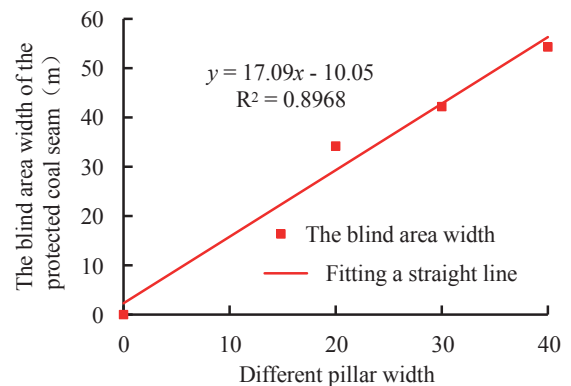

Figure 12. The relationship between the width of different pillars and the width of the distressed blind-zone in the protected layer

the coal pillar in the upper protective layer, the stress concentration range of the protected coal seam under the pillar is decreasing; when the upper protective layer is mined without coal pillars, there is no stress concentration area in the protected

layer below the original coal pillars. When the width of coal pillars is 0 m, 20 m, 30 m, and 40 m, the maximum vertical stress values of under-protected layer below the coal pillars are 11 MP, 15 MP, 19 MP, and 21 MP, which are 0.84, 1.15, 1.45, and 1.6 times respectively for the original rock stress, that is, the protected layer under the original coal pillar will produce a pressure relief effect when non-coal pillar is used, which eliminates the distressed blind-zone.

Conclusions

(a) By using similar material simulation and numerical simulation, the deformation evolution law of surrounding rock of semi-coal-rock working bed is obtained. During the excavation period, the deformation of surrounding rock is symmetrical distribution, and in the first mining advance influence stage, the support point of the side roof of the working face sinks due to the advance support pressure of the working face, the roof deviates, the deformation of the side coal wall of the working face is serious, the damage depth of the surrounding rock and the development of cracks increase. In the retaining roadway stage, the roof is further rotated and subsided due to the deformation of the empty roof and filling body, and the high-strength filling body is embedded in the floor. The floor heave is serious, the deviation is obvious, and the deformation of coal side under high abutment pressure is serious in the advanced stage of secondary mining.

(b) The mechanism of filling body in semi-coal seam is analyzed, and the mechanical calculation model of filling body is established. The stress components of filling body and its internal stress are obtained. It shows that the horizontal stress gradually decreases from the side of goaf to the roadway, and the upper and lower parts of filling body bear higher vertical stress and shear stress, which is the key point of support.

(c) On-site engineering practice shows that relative to the south wing of the mine is not protected by protective layer mining, the pressure of the gas in the protected coal seam is relieved and the permeability is increased after adopting the non-coal pillar mining technology for semi-coal rock of protective layer in the north wing of the mine. The gas extraction scalar is up to 18m³/min, and the maximum concentration is about 90%. The gas extraction scalar and concentration at each drilling field undergoes smoothness, ascent, descent, and recovery in turn. The stage shows that the overall pressure relief effect of the non-coal pillar mining technology for semi-coal rock of protective layer is significant. \notin

Acknowledgements

This research was supported by the National Natural Science Foundation of China (No.51874276, No.52004273) and China Postdoctoral Science Foundation (No.2019M661992).

References

- Abubakary, S., Micah, N., & Jenny, G. (2015). Evaluation of the impact of commodity price change on mine plan of underground mining. *International Journal of Mining Science and Technology*, 25, 375-382.
- Bustin, R. M., & Clarkson, C. R. (1998). Geological controls on coalbed methane reservoir capacity and gas content. *International Journal of Coal Geology*, 38, 3-26.
- Chen, Y., Bai, J. B., Wang, X. Y., Ma, S. Q., & Xu, Y. (2003). Support technology research and application inside roadway of gob-side entry retaining. *Journal of China Coal Society*, 37, 903-910.
- Chen, D., Pan, Z., Shi, J. Q., Si, G., Ye, Z., & Zhang, J. (2016). A novel approach for modelling coal permeability during transition from elastic to post-failure state using a modified logistic growth function. *International Journal of Coal Geology*, 163, 132-139.
- Cheng, Y. P., Yu, Q. X., & Yuan, L. (2003). Gas extraction techniques and movement properties of long distance and pressure relief rock mass upon exploited coal seam. *Journal of Liaoning Technical University*, 22, 483-486.
- Cheng, Y. H., Jiang, F. X., & Lin, J. K. (2012). Experimental study on gob-side entry retaining by roadside flexible packing under hard roof. *Journal of Mining and Safety Engineering*, 29, 757-761.
- He, M. C., Chen, S. Y., Guo, Z. B., Yang, J., Gao, Y. B. (2017). Control of surrounding rock structure for gob-side entry retaining by cutting roof to release pressure and its engineering application. *Journal of China University of Mining and Technology*, 46, 959-969.
- Jiang, J. P., Dai, J., Li, Q. H. (2013). Failure law and application of complex structure thin coal seam mining face. *Journal of China Coal Society*, 38, 1912-1916.
- Khademalhosseiny, M. S., Nadoushan, M. A., & Radnezhad, H. (2017). Site selection for landfill gas extraction plant by fuzzy analytic hierarchy process and fuzzy analytic network process in the city of Najafabad, Iran. *Energy & Environment*, 28(7), 763-774.
- Li, D. Q. (2014). Underground hydraulic mining of thin sub-layer as protective coal seam in coal mines. *International Journal of Rock Mechanics and Mining Sciences*, 67, 145-154.
- Li, L., Bai, J. B., Xu, Y., Xiao, T. Q., Wang, X. Y., & Zhang, K. X. (2011). Research on rock control of roadway with complex roof driven along goaf. *Journal of Mining and Safety Engineering*, 28(3), 376-383.
- Liu, H. B., Cheng, Y. P., Song, J. C., Shang, Z. J., & Wang, L. (2009). Pressure relief, gas drainage and deformation effects on an overlying coal seam induced by drilling an extra-thin protective coal seam. *International Journal of Mining Science and Technology*, 19, 724-729.
- Liu, Y. K., Zhou, F. B., Liu, Y., Liu, C., & Hu, S. Y. (2011). Experimental and numerical investigation on the deformation of overlying coal seams above double-seam extraction for controlling coal mine methane emissions. *International Journal of Coal Geology*, 87, 139-149.
- Liu, H. Y., Cheng, Y. P., Chen, H. D., Mou, J. H., & Kong, S. L. (2013). Characteristics of mining gas channel expansion in the remote overlying strata and its control of gas flow. *International Journal of Mining Science and Technology*, 23, 481-487.
- Ma, L. Q., Zhang, D. S., Chen, T., & Fang, G. W. (2007). Study on packing body supporting resistance of enter-in packing for in-situ gob-side entry retaining in fully-mechanized top-coal caving mining face. *Chinese Journal of Mechanical Engineering*, 26, 544-550.
- Rosa, M., Barboza, E. G., Menegon, B. S., Frota, P. C., & Anoni, R. (2016). Geological evolution and inundation hazard: an analysis through geotechnologies. *Journal of Coastal Research*, (752), 1227-1231.
- Wu, C. F., Zeng, Y., & Qin, Y. (2004). Present situation, application, and development of simultaneous extraction of coal and gas. *Journal of China University of Mining and Technology*, 33, 137-140.
- Yuan, L. (2008a). Gas distribution of the mined-out side and extraction technology of first mined key seam relief-mining in gassy multi-seams of low permeability. *Journal of Mining and Safety Engineering*, 3, 1-7.
- Yuan, L. (2008b). The technique of coal mining and gas extraction by roadway retaining and borehole drilling. *Journal of China Coal Society*, 33, 898-902.
- Zhou, H., Zhang, R., Cheng, Y., Dai, H., Ge, C., & Chen, J. (2015). Methane and coal exploitation strategy of highly outburst-prone coal seam configurations. *Journal of Natural Gas Science and Engineering*, 23, 63-69.
- Zhou, F., Xia, T., Wang, X., Zhang, Y., Sun, Y., & Liu, J. (2016). Recent developments in coal mine methane extraction and utilization in China: a review. *Journal of Natural Gas Science and Engineering*, 31, 437-458.