



RESEARCH ARTICLE

Design and Implementation a Non-uniform Helical Antenna in Frequency Range of 450–850 MHz for Ultra-high-frequency Television Application

Firas Muhammad Zeki Mahmood*, Adil H. Mohammed Al-Dalawie

Department of Communication and Computer, College of Engineering, Cihan University-Erbil, Iraq

ABSTRACT

In a domestic region, the people are living inside cities, they complaining from the weak of local TV broadcasting signals in frequency range of 450–850 MHz, in this paper we got a solution by increase the gain antenna by design new antenna have a wideband and high gain compare with antennas are available in the local market. A non-uniform helical antenna designed using helical antenna calculator according to equations then implemented and measured the radiation pattern and gain of antenna, then compare with commercial loop antenna gain found increase in received power about 10–12 dB more than loop antenna gain. The results of measurement applied in Matlab program to draw the pattern of the antenna.

Keywords: Measurements and television, non-uniform helical antenna, ultra-high-frequency antenna

INTRODUCTION

The IEEE Standard Definitions of Terms for Antennas (IEEE Std 145–1983) defines the antenna or aerial as “a means for radiating or receiving radio waves.”^[1]

A convenient element for providing circular polarization is the wire helix. The helical antenna consists of a metal conductor wound in the form of helix and backed at one end by a metal ground plane. It conveniently fed from a coaxial cable with the center conductor connected to the helix and the outer sheath connected to a circular ground plane of the radius of half-wavelength approximately. The helical geometry characterized by its diameter of turn spacing, pitch angle, uncoiled length of turn, and number of turns.^[2]

The people are living our side cities, they complain from weak of the local TV broadcasting signals, so we got a solution by increase the gain of antenna by design new helical antenna has wideband and high gain comparing what available with commercial antenna.

LINK BUDGET EQUATION

For simple formula for link budget equation can be state as,

$$Pr = Pt + Gt + Gr - L \quad (1)$$

Where, Pr is received power (dB), Pt is transmitted power (dB), Gt transmission gain (dB), Gr is receiver gain (dB), and L is total losses (dB).

The item gain will contain the two main antennas gain for transmitting and receiving, the focus on receiving gain which is in our control hand and we success to give a way to boost the received power if increase the gain of receiver antenna.^[3]

NON-UNIFORM HELICAL ANTENNA

According to exemplary embodiments of the present invention, non-uniform helical antenna is described for use in two or more frequencies tuning to both resonance frequencies can be accomplished by varying parameters of the helical antenna including, for example, the pitch angle, coil diameter, length, and number and spacing of the coil turns; Figure 1 shows an example for non-uniform helical antenna.^[4]

Corresponding Author:

Firas Muhammad Zeki Mahmood, Department of Communication and Computer, College of Engineering, Cihan University-Erbil, Iraq. E-mail: firmas.zeki@cihanuniversity.edu.iq

Received: Apr 10, 2019

Accepted: Apr 24, 2019

Published: Aug 20, 2019

DOI: 10.24086/cuesj.v3n2y2019.pp75-79

Copyright © 2019 Firas Muhammad Zeki Mahmood, Adil Hussein Mohammed Al-Dalawie. Al-Aubi. This is an open-access article distributed under the Creative Commons Attribution License.

MAIN PARAMETERS OF HELICAL ANTENNA

Pitch Angle

Pitch angle is the angle between a line tangent to the helix wire and plane normal to the helix axis.

$$\alpha = \arctan \frac{S}{\pi D} \quad (2)$$

Where, α is the pitch angle, S is the turn spacing (center to center), and D is the diameter of helical.

And,

$$H = NS \quad (3)$$

Where, H is total height of helix antenna, N is number of turns on the helix antenna, and S is the turn spacing (center to center).

The helix antenna functions for pitch angles (α) between 12° and 14° . Typically, the pitch angle taken as 13° .^[3]

The antenna in Figure 2 is a left-handed helix antenna because if you curl your fingers on your left hand around the helix your thumb would point up (also, the waves emitted

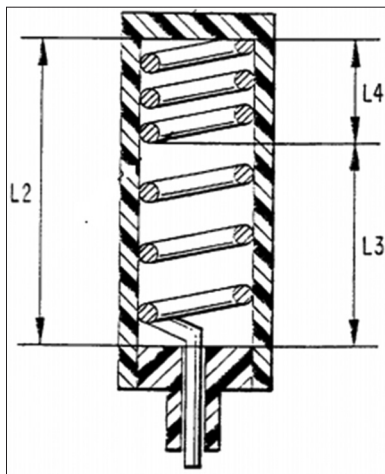

Figure 1: Non-uniform helical antenna

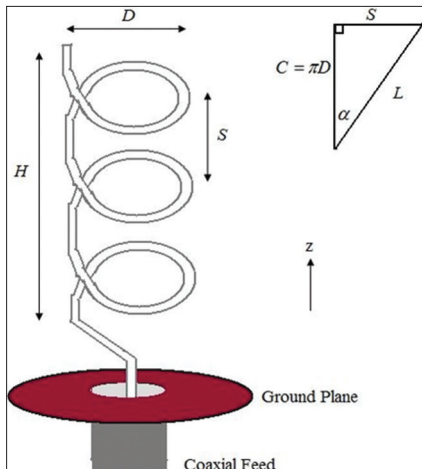

Figure 2: Main parameters of helical antenna

from this helix antenna are left hand circularly polarized). If the helix antenna wound in another way, it would be a right-handed helical antenna.

The radiation pattern will be maximum in the $+z$ direction (along the helical axis in Figure 1). The design of helical antenna primarily based on empirical results, and the fundamental equations represented here.

Helix antennas of at least 3 turns will have close to circular polarization in the $+z$ direction when the circumference C is close to a wavelength:

$$\frac{3\lambda}{4} \leq C \leq \frac{4\lambda}{3} \quad (4)$$

Once the circumference C chosen, the inequalities above roughly determine the operating bandwidth (BW) of the helix antenna.^[2,5]

For instance, if $C = 0.5$ m, then the highest frequency of operation will be given by the smallest wavelength that fits into the above equation, or

$$\lambda = 0.75 C = 0.375 \text{ m} \quad (5)$$

which corresponds to a frequency of 850 MHz, the lowest frequency of operation will be given by the largest wavelength that fits into the above equation, or

$$\lambda = 1.33 C = 0.667 \text{ m} \quad (6)$$

which corresponds to a frequency of 450 MHz. Hence, the fractional BW is 56%, which is true of axial helical antennas in general.^[6]

Input Impedance

The helix antenna is a traveling wave antenna, which means the current travels along with the antenna and the phase varies continuously. In addition, the input impedance is primarily real and can be approximate in ohms^[7] by

$$Z_{in} = 140 \frac{C}{\lambda} \quad (7)$$

Radiation pattern of the helical antenna

The helix antenna functions well for pitch angles (α) between 12° and 14° . Typically, the pitch angle taken as 13° .

The normalized radiation pattern for the E-field components given by:

$$E_\theta \propto E_\phi \propto \sin \frac{\pi}{2N} \cos \theta \frac{\sin \frac{N\Omega}{2}}{\sin \frac{\Omega}{2}} \quad (8)$$

$$\Omega = KS(\cos \theta - 1) - \pi \left(2 + \frac{1}{N} \right) \quad (9)$$

For circular polarization, the orthogonal components of the E-field must be 90° out of phase. This occurs in directions near the axis (z -axis in Figure 2) of the helix.^[5]

The axial ratio for helix antennas decreases as the number of loops (N) added and can be approximated by:

$$AR = \frac{2N + 1}{2N} \tag{10}$$

Where, AR is axial ratio.

Gain of the Antenna

The gain of the helix antenna can be approximated by,

$$G = \frac{6.2C^2NS}{\lambda^3} = \frac{6.2C^2NFS^3}{C^3} \tag{11}$$

N the above, C is the speed of light. Note that for a given helix geometry (specified in terms of C, S, and N), the gain increases with frequency. For an N = 10 turns helix that has a 0.5 m circumference as above, and a pitch angle of 13° (giving S = 0.13 m), the gain is 8.3 (9.2 dB).^[8]

For the same example helix antenna, the pattern is shown in Figure 3.

The half-power beamwidth for helical antennas can be approximate (in degrees)^[3] by:

$$HPBW = \frac{65\lambda}{C\sqrt{NS/\lambda}} \tag{12}$$

POLARIZATION

Linear polarization occurs when electromagnetic waves broadcast on a single plane (either vertical or horizontal). Compared to linear polarized antennas of the same gain, circular polarized antennas will have a shorter read range because they lose about 3 dB splitting their power across two separate planes.^[9,10]

DESIGN SPECIFICATIONS

It is considered the helical antenna design specifications which are as follows:

- Frequency range: 450–850 MHz
- Gain: 10 dBi ± 0.5 dB
- Axial ratio: <1.5.

Using online antenna calculator program to calculate the parameters that are required to the helical antenna design as shown in Figures 4 and 5, respectively.^[11]

The main factors of helical antenna were entire such as wavelength, number of turns, and the space between each coil to calculate the antenna gain and wire diameter, half-power beamwidth, beamwidth first nulls, and effective aperture. Table 1 shows the important factor for implemented the non-uniform helical antenna.

Table 1: Main parameters of non-uniform antenna designed

Parameters	At 850 MHz	At 450 MHz
Number of turns	3	5
Spacing between coils	8.82 cm	16.7 cm
D (Diameter)	11.2 cm	21.2 cm
G (Antenna gain)	9.55 dBi	11.8 dBi
Z (Characteristic impedance)	150 Ω	150 Ω

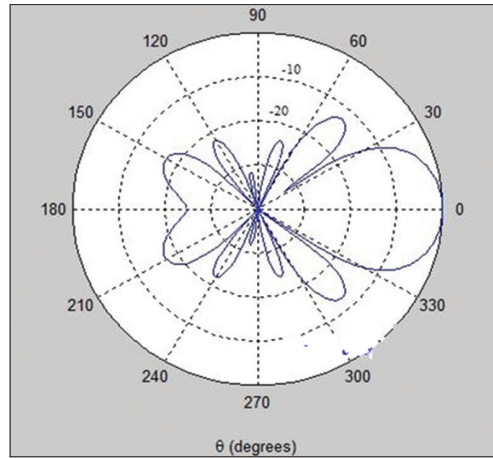

Figure 3: Normalized radiation pattern for helical antenna (dB)

Input:	
lambda (wavelength), OR f (frequency)	0.667 (m) OR 450 (MHz)
N (Number of Turns)	5
S (Spacing between coils)	0.25 (wavelengths)
Compute	
G (Antenna Gain)	11.8 (dBi) Relative to an isotropic antenna
Z (Characteristic Impedance)	150 (Ohms)
D (Diameter)	21.2 (cm)
S (Spacing between coils)	16.7 (cm)
L (Length of wire)	356 (cm)
HPBW (Half Power BW)	46.5 (degrees)
BWFN (BW first nulls)	103 (degrees)
Ae (Effective Apperture)	0.532 m ²

Figure 4: Helical antenna design with 450 MHz

Input:	
lambda (wavelength), OR f (frequency)	0.353 (m) OR 850 (MHz)
N (Number of Turns)	3
S (Spacing between coils)	0.25 (wavelengths)
Compute	
G (Antenna Gain)	9.55 (dBi) Relative to an isotropic antenna
Z (Characteristic Impedance)	150 (Ohms)
D (Diameter)	11.2 (cm)
S (Spacing between coils)	8.82 (cm)
L (Length of wire)	130 (cm)
HPBW (Half Power BW)	60.0 (degrees)
BWFN (BW first nulls)	133 (degrees)
Ae (Effective Apperture)	0.0894 m ²

Figure 5: Helical antenna design with 850 MHz

THE IMPLEMENTATION OF NON-HELICAL ANTENNA

Figure 6 shows the antenna which is designed using helical antenna calculator according to equations then implemented from 5 turns for 450 MHz and 3 turns for 850 MHz with circular



Figure 6: Non-uniform helical antenna manufactured

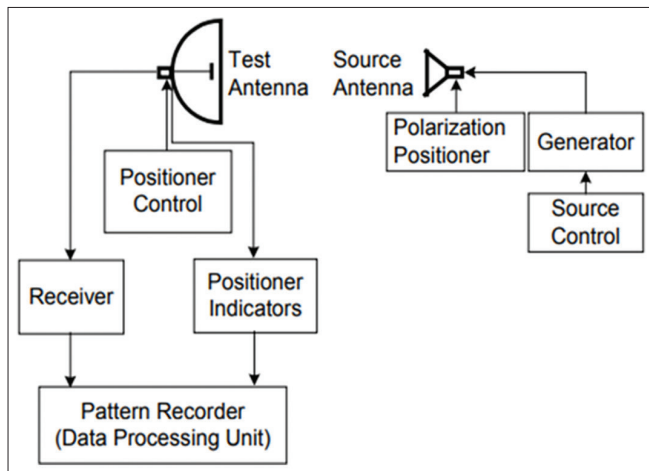

Figure 7: Set of antenna test^[2]



Figure 8: Implemented non-uniform helical antenna under test

plate ground and other parameters as shown in Table 1 to cover ultra-high-frequency band for TV application then tested in the laboratory of antenna and microwave/communication and computer department/Cihan University – Erbil.

MEASUREMENTS METHOD

The far-field patterns measured on the surface of a sphere of constant radius. Any position on the sphere identified by the directional angles θ and ϕ of the spherical coordinate system. A principal plane must contain the direction of maximum radiation. A simplified block diagram of a pattern measurement system is given in Figure 7. The method used a commercial

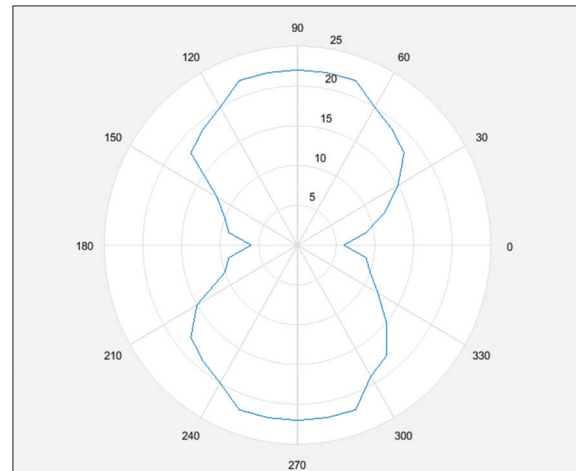

Figure 9: Commercial loop antenna radiation pattern

Table 2: Measurements of commercial loop antenna

Step no.	Angle (Degree)	Power (dBm)	Step no.	Angle (Degree)	Power (dBm)
1	-180	-16	20	10	-19
2	-170	-19	21	20	-20
3	-160	-22	22	30	-22
4	-150	-25	23	40	-28
5	-140	-28	24	50	-29
6	-130	-29	25	60	-30
7	-120	-30	26	70	-32
8	-110	-31	27	80	-32
9	-100	-32	28	90	-32
10	-90	-32	29	100	-32
11	-80	-32	30	110	-31
12	-70	-32	31	120	-30
13	-60	-30	32	130	-29
14	-50	-29	33	140	-28
15	-40	-28	34	150	-25
16	-30	-22	35	160	-22
17	-20	-20	36	170	-19
18	-10	-19	37	180	-16
19	0	-16			

Table 3: Measurements of non-uniform helical antenna implemented

Step no.	Angle (Degree)	Power (dBm)	Step no.	Angle (Degree)	Power (dBm)
1	-180	-22	20	10	-9
2	-170	-21	21	20	-10
3	-160	-20	22	30	-12
4	-150	-19	23	40	-15
5	-140	-18	24	50	-17
6	-130	-15	25	60	-18
7	-120	-18	26	70	-19
8	-110	-20	27	80	-20
9	-100	-22	28	90	-21
10	-90	-21	29	100	-22
11	-80	-20	30	110	-20
12	-70	-19	31	120	-18
13	-60	-18	32	130	-15
14	-50	-17	33	140	-18
15	-40	-15	34	150	-19
16	-30	-12	35	160	-20
17	-20	-10	36	170	-21
18	-10	-9	37	180	-22
19	0	-6			

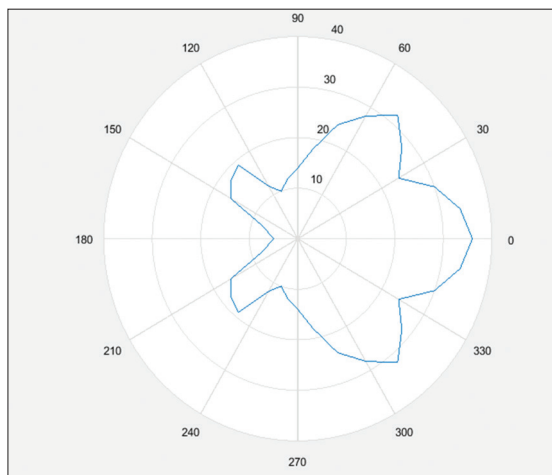

Figure 10: Non-uniform helical antenna radiation pattern

loop antenna used in local market and implemented non-uniform helical antenna; Figure 8 shows implemented non-uniform helical antenna under test. Tables 2 and 3 show the radiation pattern of loop antenna and measurements of

radiation pattern of non-uniform helical antenna under test, respectively, these results show the deferent received power about 10–12 dB more with non-uniform helical antenna gain.

The results of measurements applied in Matlab program to draw the pattern of the antenna; Figure 9 shows loop antenna radiation pattern and Figure 10 shows non-uniform helical antenna radiation pattern, respectively.

CONCLUSION

In this paper, designed and implemented a non-uniform helical antenna by using helical antenna calculator and equations then tested with frequency range 450 to 850 MHz for TV receiver and compare the gain measurements with commercial loop antenna in local market. The results of measurement show the deferent received power about 10–12 dB more with non-uniform helical antenna gain but with circular polarization that meaning the antenna will lost 3 dB because the TV broadcasting transmitted linear polarization; still, the gain of antenna manufactured improved about 8 dB.

REFERENCES

1. A. C. Balanis. "Antenna Theory Analysis and Design". 3rd ed. Hoboken, New Jersey: John Wiley and Sons, Inc., 2005.
2. F. R. Connor. "Antennas: Introductory Topics in Electronics and Telecommunication". 2nd ed. London: Edward Arnold, 1989.
3. J. D. Kraus. The helical antenna. In: "Antennas". Ch. 7. New York, USA: McGraw-Hill, 1988, p. 265-339.
4. Available from: <https://www.patentimages.storage.googleapis.com/US6112102>. 2019.
5. W. L. Stutzman. "Antenna Theory and Design". 3rd ed. New York: McGraw-Hill, 1998.
6. E. P. Ogherohwo and B. Barnabas. "Design, construction and performance analysis of helical antenna operating at 5.8ghz". *International Journal of Advanced Research in Physical Science*, Vol. 2, no. 11, pp. 29-38, Nov 2015.
7. M. M. Ilić, S. V. Savić and P. Djondović. "Internal Matching of UHF Helical Antenna Exciters for Magnetic Resonance Imaging". API 1.1. *Proceeding of 3rd International Conference on Electrical, Electronic and Computing Engineering*, Zlatibor, Serbia, 2016, pp. 1-5.
8. Y. Liang, J. Zhang, Q. Liu, and X. Li. "High power dual branch helical antenna". *IEEE Antennas and Wireless Propagation Letters*, vol. 17, no. 3, pp. 472-475, 2018.
9. J. L. Dinkić, D. I. Olćan, A. G. Zajić and A. R. Djordjević. "Comparison of Optimization Approaches for Designing Non Uniform Helical Antennas," in 2018 IEEE International Symposium on Antennas and Propagation and USNC/URSI National Radio Science Meeting, Boston, MA, USA, 2018, pp. 1581-1582.
10. Available from: <https://www.blog.atlasrfidstore.com/circular-polarization-vs-linear-polarization>. 2018.
11. Available from: <http://www.daycounter.com/Calculators/Helical-Antenna-Design-Calculator.phtml>. 2018.