

A Study on Variable Speed Constant Frequency AC Double-Fed Exciting Wind Power Generation System and Its Control Technology

Xuan Zhu, Mao Lin

Department of Mechanical Engineering, Hainan University, Hainan 570228, China
 xuanzhu@163.com

As a green and recycling energy, wind energy has attracted more and more attention of the people. Relevant utilization techniques are also becoming more and more deep and mature. Compared with traditional wind power technology, variable speed constant frequency AC double-fed exciting wind power generation technology has more advantages, such as small volume, light weight and high efficiency. For grid-side converter used in the wind power generation system, a mathematic model under synchronous coordinate system is established and a vector control strategy of grid-side converter based on grid voltage orientation is obtained through detailed derivation accordingly. It mainly describes the grid connection methods of variable speed constant frequency AC double-fed exciting motor: no-load grid connection, direct grid connection and load carrying grid connection. Based on above theoretical analysis, this paper establishes a set of simulation platform and test bed with rated power 4kW and gives its structure charts.

1. Introduction

As is known to all, there are limited fossil energies to be developed and used by human beings on earth, and they are non-renewable. With gradual improvement and speeding of global industrialization process, global countries have a rising demand for energies. But, common coal, petroleum and natural gas are gradually exhausting. In other words, if without controlling, fossil energies stored on earth for several hundred million years can be consumed by the human in the following two hundred years (Han et al., 2017). Meanwhile, fossil energies widely used also seriously damage the geocological environment. For example, carbon dioxide and oxygenated sulphide emitted by burning of fossil fuels can directly cause greenhouse effect and acid rain. Faced with the challenge of sustainable development of society and economy, that how to solve the increasingly urgent energy crisis and relieve the environmental degradation is the major task for social development of human beings (Kim et al., 2017). Currently, global countries have reached an agreement on energy crisis and environmental degradation, i.e. seeking and developing renewable energy sources. On this basis, relevant preferential policies should be prepared to support wide application of new energies. During development and application of multiple renewable energy and new technology, wind energy, one of major members, is paid to many attentions (Liu et al., 2016). This paper mainly studies the variable speed constant frequency AC double-fed exciting wind power generation system.

2. Grid-side converter model

In the variable speed constant frequency AC double-fed exciting wind power generation system, possible running conditions of grid-side converter and rotor-side converter are shown in Figure 1 and Figure 2: diagram for running conditions of wind power generation system under secondary-synchronous and super-synchronous speed (Okedu, 2017). When the secondary-synchronous power generation is neglected, the slip s is more than 0; the grid-side converter is operated in the rectification conditions; rotor-side converter flows through slip power and is operated in the contravariant conditions; in the super-synchronous power generation conditions, the slip s is less than 0 and rotor-side converter is operated in the contravariant conditions and only flows through slip power; the grid-side converter is operated in the feedback status (Wang et al., 2016).

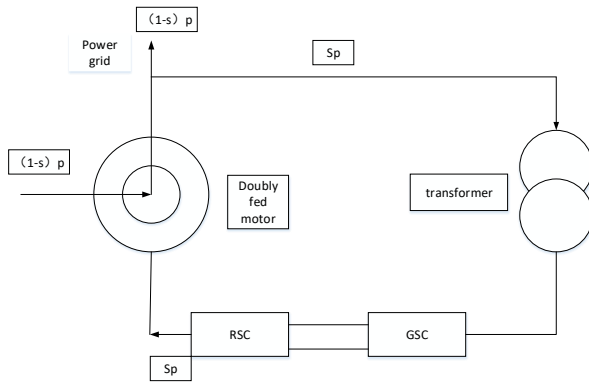

Figure 1: Time - to - back converter power flow

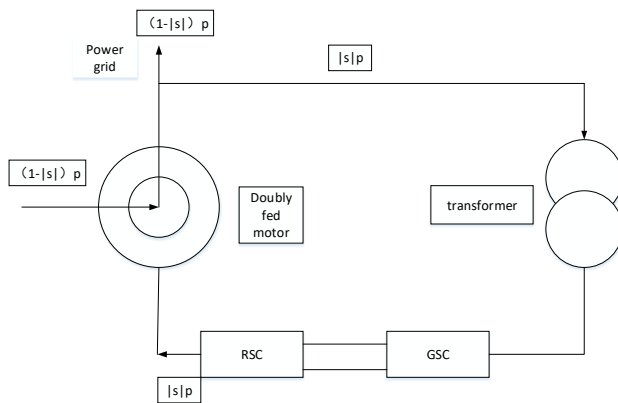

Figure 2: Super-synchronous power generation power system back - to - back converter power flow

3. Control strategy of grid-side converter

If the frequency for synchronously rotating dq reference coordinate system to same as grid frequency, transfer function of current control loop can be directly obtained through the equation and grid-side converter object model:

$$\frac{\dot{v}_d}{\dot{i}_d} = \frac{\dot{v}_q}{\dot{i}_q} = R + sL \tag{1}$$

Grid voltage synthesis vector is fixed at d axis of synchronous rotation system, then $\begin{cases} v_d = const \\ v_q = 0 \end{cases}$

It's further simplified according to the converter object model, i.e. requirements for v_{d1} and v_{q1} output by bridge arm should be:

$$\begin{cases} v_{d1}^* = -\dot{v}_d + \omega L \dot{i}_q + v_d \\ v_{q1}^* = -\dot{v}_q - \omega L \dot{i}_d \end{cases} \tag{2}$$

There is current coupling among two voltage loops Ingrid-side converter model with conversion of dq rotary coordinate system, i.e. change of current component i_q at q axis may cause i_d change through coupling item $\omega L i_q$. Similarly, change of current component i_d at d axis may cause i_q change through coupling item $\omega L i_d$. Such coupling relationship is unbeneficial for design of voltage and current controller. So, grid voltage feedforward compensation and converter AC-side current cross decoupling are introduced herein (Xu, et al, 2017).

Through simplified block diagram for current inner loop of grid-side converter after adding grid voltage feedforward and decoupling control, it can be seen that the coupling effect is eliminated and vector below AC-side current dq axis forms two independent loops without mutual influence. They are linear system with single input and single output and independent controller. Below synchronously rotated dq reference coordinate, active power and reactive power absorbed by the system from grid side can be expressed as:

$$\begin{aligned} P &= v_d \dot{i}_d + v_q \dot{i}_q = v_d \dot{i}_d \\ Q &= v_q \dot{i}_d - v_d \dot{i}_q = -v_d \dot{i}_q \end{aligned} \quad (3)$$

If active power is positive, it means that energy flows from grid to converter. If reactive power is positive, it means that converter is inductive to the grid and absorbs the inductively reactive current. It can be seen from circuit structure that if AC-side active power of the converter is more than active power required by the load, excessive power can be used to improve DC capacitor voltage. If AC-side active power is less than active power required by the load, the capacitance discharges the energy and the voltage is reduced (Yao Y., 2016). As current component is in direct proportion to active power, the voltage can be controlled to get the command value of active current component.

Generally speaking, grid-side converter is operated in the rectifier or feedback condition of unit power factor, so command value of reactive current component is set to 0. Voltage loop is controlled to get reference command of shaft current component, which is directly preset. Then, it's subtracted by actual current component to get the error, which should be input into the controller. Control results, cross decoupling item and grid voltage feedforward compensation are used to get reference voltage need to be input at AC side of the converter. Through inverse transformation, reference voltage of rotary coordinate system can be changed to a stationary coordinate (Ye, et al, 2016). Voltage in the coordinate can be used to produce drive signals of switch tube of grid-side converter controlled by SVPWM. Then, it's necessary to get the control system of above grid-side converter.

4. Direct grid connection, No-load grid connection and Load carrying grid connection

As shown in Figure 3, motor rotor should be firstly disconnected with converters, i.e. switch k2 is disconnected and switch k1 is connected. Stator-side of double-fed motor is directly connected to the grid. At this time, it is equivalent that large inductive load is connected to the grid and main stator current is exciting current with small impact. The DC motor is started for non-load operation. When its rotating speed is increased to the preset slip range ± 0.5 , it's necessary to connect the switch k2 and start the rotor-side converter and input exciting power. In this way, the system is directly operated under generation without switching the control strategy.

As shown in Figure 4, rotor-side converter is directly connected to the rotor side of double-fed motor and stator side is connected to the grid through bidirectional thyristor. Control method: DC motor is adjusted to reach a certain speed, i.e. fixed slip ratio. Before connection of switch k1, i.e. grid connection, rotor-side converter should be controlled to achieve that inductive voltage at stator side should have same amplitude, same frequency and same phase as grid-side voltage. Then, bidirectional thyristor k1 is triggered to realize grid connection.

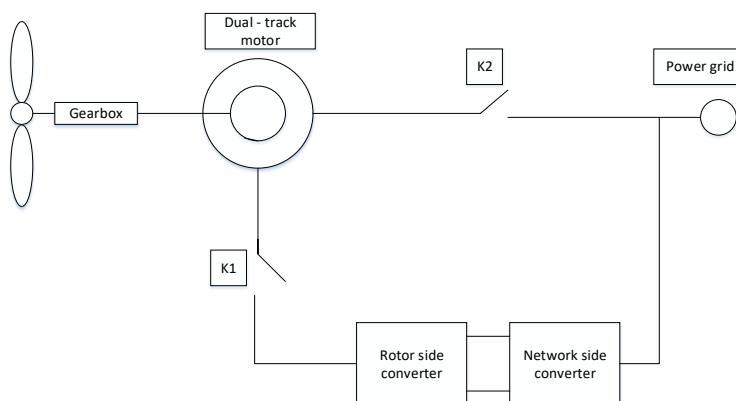

Figure 3: Variable speed constant frequency AC excitation doubly-fed wind power generation system direct and grid diagram

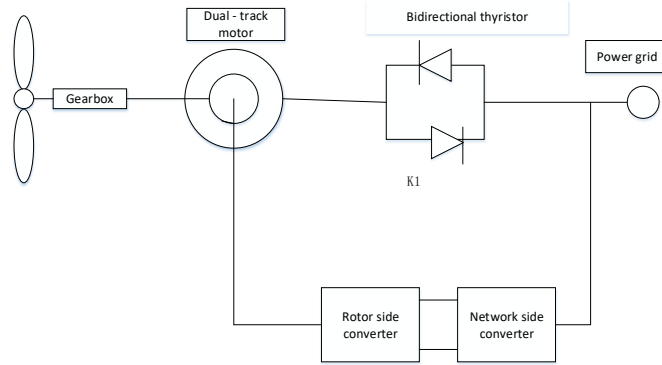

Figure 4: Wind power generation system without load and network diagram

As shown in Figure 5, detailed description on disconnection of switch k1 is not described here again. When the system is operated independently with load, the control mode has been stated in the chapter 3. When output voltage at stator side of double-fed motor reaches the grid connection requirements, it's necessary to give trigger signals to bi-directional non-thyristor switch to trigger connection and grid connection operation.

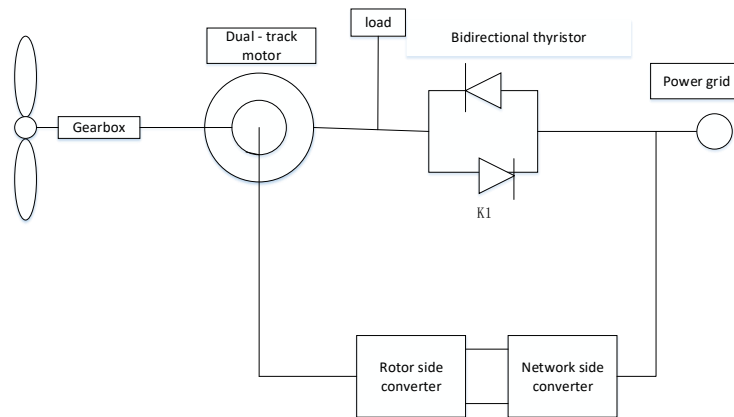

Figure 5: Schematic diagram of wind power generation system with load

5. Characteristics of these grid connection modes

During no-load grid connection, voltage at output rotor side modulated by SVPWM after startup of rotor-side converter includes sub-superior frequency switching harmonics. As stator side is disconnected and not connected with filter capacitor, it means that high-frequency harmonics generated by rotor-side converter can be transferred from rotor side to stator side. Therefore, in order to get a quality side voltage of stator, filter capacitor should be added to the stator side or between output inductance at rotor side and rotor (filtering high frequency harmonic voltage entering the rotor, inductive voltage at stator side should have no high frequency harmonics). Filter capacitor connected in the stator side, rotor leakage inductance and stator leakage inductance are used to form an output low-pass filter. Filter capacitor connected in the rotor side, output capacitor in the rotor side, rotor leakage capacitor of the motor and stator leakage capacitor are used to form a LCL filter. Resonant frequency is generally obtained at the place with switch frequency more than 10 times of output voltage frequency and less than one tenth. In addition, filter capacitor connected in the stator side shouldn't be used to excessively compensate for reactive power of the power generator. Otherwise, the system may be excessively excited, especially during non-load, and become instable.

Load carrying grid connection and no-load grid connection have same control objective and strategy before and after grid connection. The only difference is that current in the stator side is not 0 after loading and current in the stator side should be collected for controlling. In extreme conditions, i.e. large load impedance, current in the stator side of the motor is very small. At this time, there are no obvious different. During actual application, rotor-side converter and motor should also provide active power for resistive load. At this time, the power is only determined by the load. Matters to be noticed should be it's prohibited to select too small load.

Because, large power consumed by small load may greatly increase the active power sent by the motor under rated conditions.

6. Results

Motor parameters: Model is Z2-52; rated power is 7.5kw; rated voltage is 220V; rated current is 41A.

Wind power generation system in the simulation and experimental is composed of two subsystems, i.e. grid-side converter subsystem and rotor-side sub-converter system. Grid-side converter and rotor-side converter on the test bed are centered on TMS320LF240. Power device is provided with two units of IGBT modules, which are respectively provided with sampling, PWM pulse generation, display and protection control panel. There are no communication device equipment between two converters. Independent control system can be used for completing their respective functions.

Among them, parameters for subsystem of grid-side converter: AC-side filter inductance is 2.6mH and designed rated current is 14A. Capacitance on the DC bus is 4700 μ F and bus buffer is RCD. AC-side of grid-side converter is not directly connected to three-phase network, but connected with power grid through three-phase transformer with rated capacity 2.5kVA and ratio of transformation 380V/110V. Wiring mode of the transformer is Δ/Y .

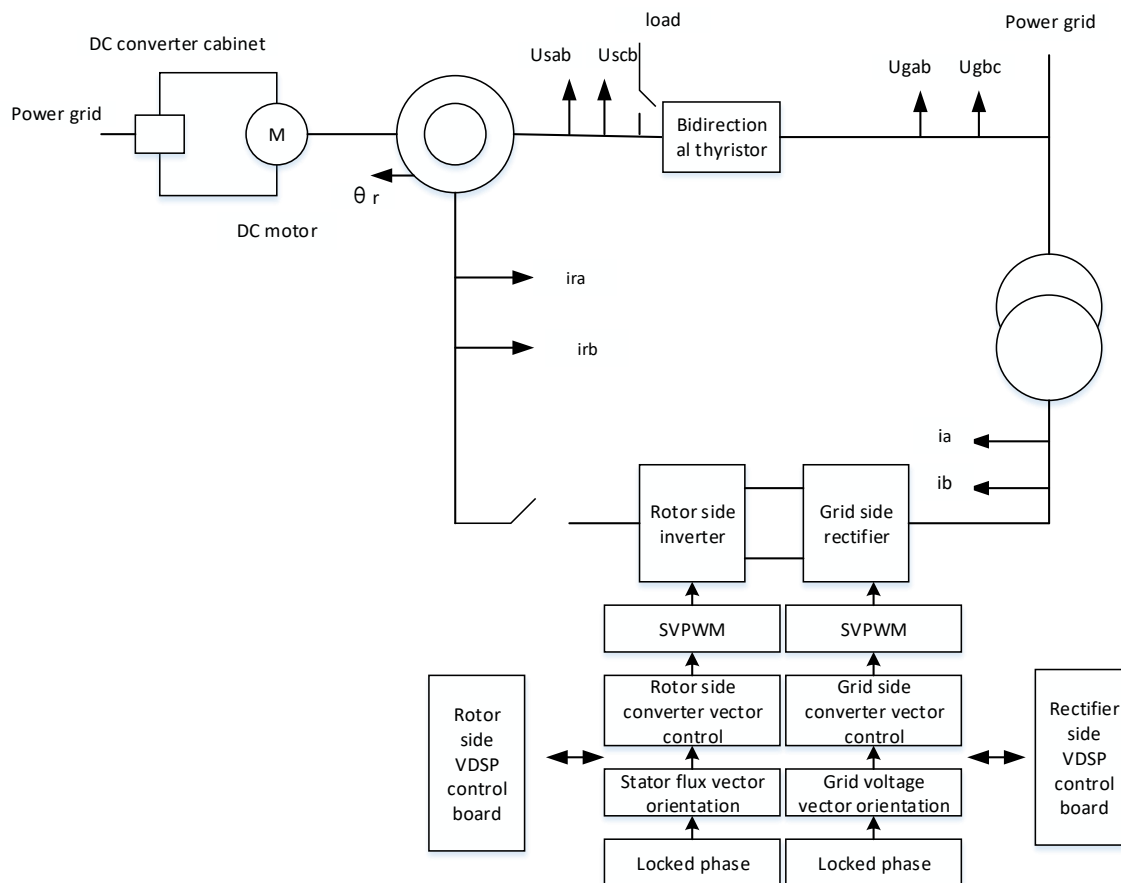

Figure 6: Wind Power Grid - Connected System Simulation and Experimental

All simulation results should be obtained through sampling, calculation and controlling of the program. As the switch frequency is 5400KHz, i.e. wave data is 1/5400s per point. During simulation, the rotating speed is set to 700r/min. Unless otherwise specified, the horizontal axis should be time axis with unit second in the following simulation results. If it's a voltage diagram, the unit of vertical coordinate should be volt. If current diagram, it should be Ampere. If active power diagram, it should be watt. If reactive power diagram, it should be volt-ampere. System structure of simulation framework platform is shown in Figure 6.

7. Conclusion

Through study of variable speed constant frequency AC wind power generation system under independent operation, non-load operation, direct grid connection and load carrying grid connection and other conditions, results show that simulation waveform and test data are basically same as the theoretical analysis, which achieves the expected effects.

Reference

- Han P., Cheng M., Chen Z., 2017, Dual-Electrical-Port Control of Cascaded Doubly-Fed Induction Machine for EV/HEV Applications, *IEEE Transactions on Industry Applications*, 53, 1390-1398, DOI: 10.1109/TIA.2016.2625770
- Kim Y., Kang M., Muljadi E., Park J.W., Kang Y.C., 2017, Power Smoothing of a Variable-Speed Wind Turbine Generator in Association With the Rotor-Speed-Dependent Gain, *IEEE Transactions on Sustainable Energy*, 8, 990-999, DOI: 10.1109/TSTE.2016.2637907
- Liu Y., Niu S., Fu W., 2016, Design of an Electrical Continuously Variable Transmission Based Wind Energy Conversion System, *IEEE Transactions on Industrial Electronics*, 63, 6745-6755, DOI: 10.1109/TIE.2016.2590383
- Okedu K.E., 2017, Effect of ECS low-pass filter timing on grid frequency dynamics of a power network considering wind energy penetration, *IET Renewable Power Generation*, 11, 1194-1199, DOI: 10.1049/iet-rpg.2016.0855
- Wang Y., Niu S., Fu W.N., Ho S.L., 2016, Design and Optimization of Electric Continuous Variable Transmission System for Wind Power Generation, *IEEE Transactions on Magnetics*, 52, 1-4, DOI: 10.1109/TMAG.2015.2487995
- Xu F., Cheng M., Zhang J., 2017, Multi-objective control of direct-driven wind power generation system with frequency separation, *Chinese Journal of Electrical Engineering*, 3, 42-50, DOI: 10.23919/CJEE.2017.7961321
- Yao Y., Cosic A., Sadarangani C., 2016, Power Factor Improvement and Dynamic Performance of an Induction Machine with a Novel Concept of a Converter-Fed Rotor, *IEEE Transactions on Energy Conversion*, 31, 769-775, DOI: 10.1109/TEC.2015.2505082
- Ye H., Pei W., Qi Z., 2016, Analytical Modeling of Inertial and Droop Responses from a Wind Farm for Short-Term Frequency Regulation in Power Systems, *IEEE Transactions on Power Systems*, 31, 3414-3423, DOI: 10.1109/TPWRS.2015.2490342