

Application of Path Selection Gateway Algorithm in Chemical Industry

Yongwu Yu

College of Computer Science, Neijiang Normal University, Neijiang 641000, China
 yyw7467@163.com

In order to solve the disadvantages such as dispersed monitoring points, problems in wiring and poor real-time capability etc. in existing environment monitoring, the remote real-time monitoring system based on wireless sensor network is designed in this paper for the air environment in chemical industry zone. The optimal method is adopted to balance the load on the basis of clustered control technology, so that the energy consumption speed of the node can be reduced; and in the meanwhile, the gateway algorithm called optimized cluster distribution and based on maximum energy-path selection among multiple paths is also proposed. Finally, the software and hardware system of monitoring system network used in chemical environment is researched, and a set of low energy-consumption system is designed based on demands; the hardware aspect includes the function and structure circuit design of the system; and the software aspect includes the MAC layer design and upper layer system. The experiment result indicates that this system is of strong operability and flexibility, which can be used to adjust the power usage of the node effectively and improve the service life of the wireless sensor network, thus the chemical factory can be under the monitoring status continuously, due to which the instantaneity and continuity of the monitoring data as well as human and property safety can be guaranteed.

1. Introduction

The occurrence of chemical industry production is the symbol for the society development, scientific and technical development and human civilization improvement (Zhioua et al., 2015), which is the important field of modern production, and also the important embodiment of modern industry (Zeng et al., 2016). With the rapid growth of Chinese economy, the chemical industry is also under rapid development; however, the occurrence frequency of chemical accidents is also increasing, which has resulted in a large number of casualties and serious economic loss, even the undesirable political influence (Yuan, 2017). On one hand, the chemical industry drives the improvement and promotion of our society, economy and people's living standard; on the other hand, it is also a great threat to people's life and property safety (Wu et al., 2017). As for the hidden dangers and disadvantages of the monitoring system in chemical industry zone, the modernized, safe, reliable, high-effective and economical research and development of air environment monitoring system is imperative (Wu et al., 2017). The environment monitoring system used in chemical industry zone based on wireless sensor network can be applied to solve the problems in environment monitoring in chemical industry zone effectively; the effective data can be detected promptly, and the monitoring method is safe, simple and reliable; in the meanwhile, the environment monitoring personnel do not have to go to the chemical industry zone for monitoring; many reasons form the objective of our R & D on environment monitoring system; the R & D of this monitoring system will be more and more important in the environment monitoring in chemical industry zone (Wang et al., 2017).

The wireless sensor network has been explored and researched widely in the world. The primary technology is to collect the site information through the effective cooperation and coordination of various sensors, and then the information will be processed by the system in the network; finally, the induced and collected information will be transmitted to the user in the form of random Ad-Hoc Network (Sironi et al., 2016). The wireless sensor network consisting of a large number of wireless sensor network nodes is widely used in many fields, such as the environment monitoring, mobile health, exploration position, military industry and

urban transportation etc (Shojaeilangari et al., 2015). Especially in the environment monitoring of chemical industry, in order to protect people's life and property and achieve the scientific prevention before the occurrence of accidents in chemical industry zone and the scientific processing after the accident, it is of great significance to reduce casualties and loss of economy and property to the maximum, and reduce the occurrence of accidents in chemical industry zone (Rodriguez, 2002). Therefore, the system which can execute the environment supervision by replacing workers in case of sudden air pollutes leakage or severe environment, and in the meanwhile, the accurate and real-time data etc. can be obtained is urgent and essential (Reh et al., 2013).

2. Hardware design

2.1 Relationship between sensing node and network power consumption

The main body of the wireless sensor network is the node; the effective sue duration of the network is directly related to the power consumption of each node (Park, 2016). The sensor node consists of four parts in total: sensor part (data collection), singlechip processor part, wireless communication part and power supply part (generally the battery is used for power supply) (Niu, 2016). Most part of the node energy is used in the idle state, and in the meanwhile, the energy required in compression data is also higher than the power consumption in transmission; in order to reduce the power consumption of the node, the power should be reduced firstly; then the node without data should be closed for temporary (Niedzinski et al., 2002). However, the power consumption of wireless node in the conversion of collected simulation signal is very small, which can be even ignored (Menzel et al., 2015). As for the power supply part, the battery module is a vital part to the sensor node, and it is not suitable in replacement; then the performance and storage of the battery may affect the node. The wireless sensor network include a large number of sensor nodes executing the monitoring task. The data is collected by each sensor in surrounding area through the remote sensing, and such data is transmitted to the receiver (McLoughlin et al., 2015). The battery used by a large number of sensor nodes is the main bottleneck for the unavailability of re-supply after the energy consumption in the wireless sensor network (Maji, 2010). Therefore, the economic and frugal management is the main approach to solve the short service life of the network. The wireless sensor network is better than networks of other types in saving battery power (Levy, 2010). The constitution and structure of the sensor node is shown in Figure 1.

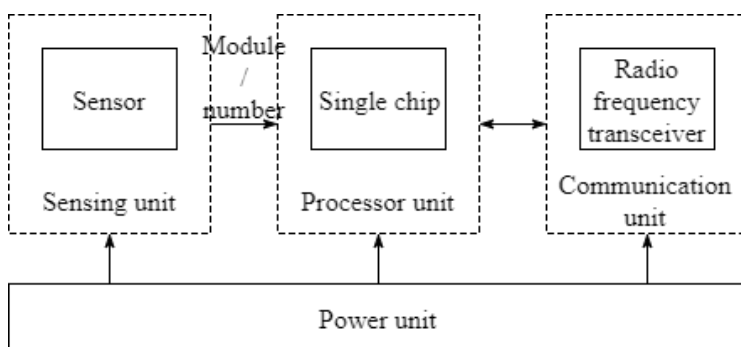

Figure 1: Constitution and Structure of Sensor Node

2.2 Function and structure of environment monitoring system in chemical factories

The sensor node in environment monitoring system of chemical industry is the basic component to the wireless sensor network. The main function of the sensor node is to collect the concentration, humidity and temperature information etc. of emissions in the environment of chemical industry zone periodically, and such information is converted into digital signal through the A/D converter and sent to the gateway node; such data is sent to the base station monitoring finally so as to ensure the real-time monitoring and data statistics (Huang et al., 2011). In the meanwhile, this node is also used to receive the command sent by the gateway node in the base station monitoring, so that the data collection can be achieved in relevant node; the information collected shall be sent to the monitoring centre in the original way. The selection of master chip in the interior is mainly made by referring to the transmitting power, power under idle state and dormancy period etc.; the design is implemented by selecting one chip with good comprehensive power and small power consumption. The wireless sensor network node in this design consists of MKL02Z8VFG4, CC2530+CC2592,

serial-port conversion chip RS232, temperature & humidity sensor chip HTU21D and power supply part etc.; see the composite frame in Figure 2.

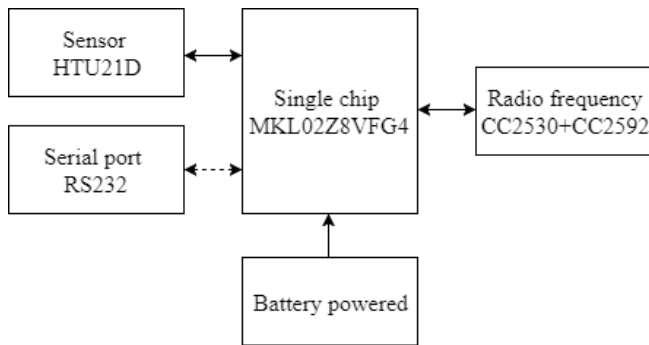

Figure 2: Composition and Structure of Node in Wireless Sensing System

3. Software design

3.1 MAC layer design

Some rules of data-link layer protocol in the wireless sensing network are directly related to the power saving capability of node and the distribution of data transmission channels (Cheng et al., 2011). When the signal transmission is required for node, then the data is transmitted through the appropriate channel, and this process is supported with the competition protocol. The network power of S_MAC is saved with timing mechanism, which means that the Sleep mode is started by setting certain period time. However, once the network loading data of such mode is less, as the empty frame should be monitored periodically, the real power saving is not achieved; and in case of periodic Sleep mode, the data block of transmission link may be caused, which may increase the delay. The basic communication figure of S_MAC between node 1 and node 2 is shown in Figure 3.

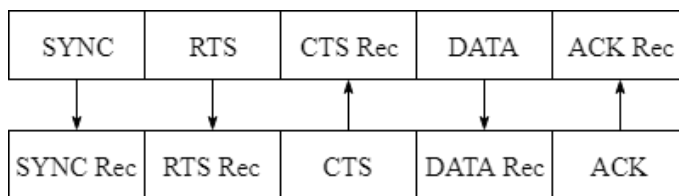

Figure 3: S_MAC Basic Communication

The S_MAC protocol is adopted in this system; the sub-frame is added into the original frame; each frame includes two states: monitoring and sleep, as shown in Figure 4.

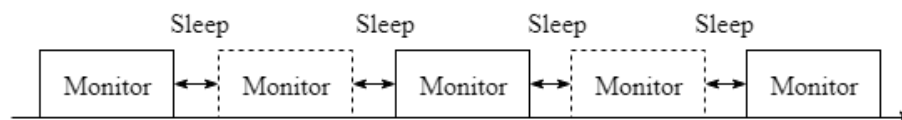

Figure 4: Schematic Diagram for Duty Ratio of Node Dynamic Condition

3.2 Node workflow

Before the node label is powered on for operation, the detection is implemented to the master chip MKL02Z8VFG4; in case such detection is not passed, the error warning will be initiated. In case the detection is passed, the internal program of the chip may reset the external elements connected (Bauer et al., 2007), then the node will enter into the working mode truly: send and transmit the data etc. How to determine the level and function is controlled and realized with algorithm. See the specific design flow in Figure 5.

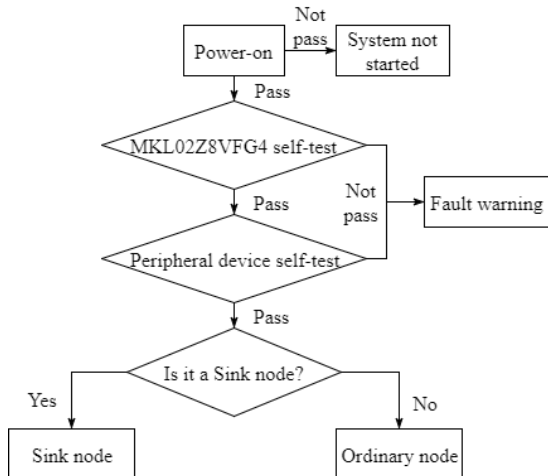

Figure 5: Flow Chart for Node Starting

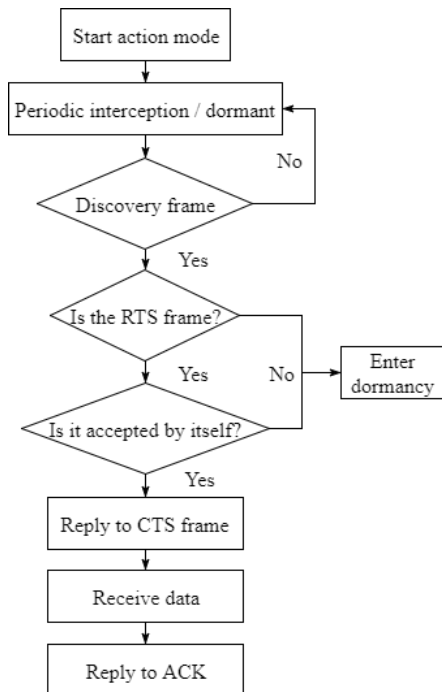

Figure 6: Data Receiving Process

In case the node of the sensing network is started up, the periodic Monitor/Dormant will be started. When the frame is received by the node label, then it should be decided that if it is the RTF message; in case it is the RTF message, then correspondence to itself should be judged; if the correspondence is achieved, the data will be received automatically, and a CTF message will be sent to the node of the previous level; then the data will be received, and the token packet will be returned to the node of the previous level after the reception, which also means the completion of the token reception. Then the RTF is transmitted to the relay node, and will be transmitted upward level by level. See the specific flow chart in Figure 6.

4. Simulation result analysis

As for the design of environment monitoring system of chemical industry production, the MATLAB6.0 simulation environment is used to simulate the power usage of node deployed in the chemical factory. Table 1 is the setting of simulation value, and Table 2 is the data generated in simulation.

Table 1: Simulation Parameters

Related parameters	Value
Number of network sensor nodes	120
Sensor node initial energy	250mAh
Network coverage area	150
Node coverage	90%
Node sleep time	15min
The maximum communication distance of the node	25m
Transceiver speed	11400bps

Table 2: Simulation Result

Related parameters	Value
Number of hop nodes	131
Maximum hops	22
Coverage rate	90%
Survival node occupancy	6.3%
Network life cycle	25 months

According to two tables above, when the maximum communication distance of the node deployed in the chemical factory is 25m, and the sending and receiving speed is 11400bps, the network can be maintained for 25 months for operation; when the normal working mode of the network is ineffective, the node living in the network is only in the proportion of 6.3%; the power of each node in the network is nearly used balanced, which can ensure the instantaneity of data in the area monitored and the long-time operation of the network .

5. Conclusion

The demands and design thought of the environment monitoring system in chemical industry is described in the beginning of this paper. Then the system structure design is introduced in the aspect of hardware design and software design; the hardware aspect is mainly introduced from the function and structure of the system as well as the circuit design; the software aspect mainly includes the MAC layer and node workflow. Based on the simulation of environment monitoring of chemical industry, the it is verified that the wireless sensing scheme designed can be used to distribute the power of node in the network averagely, and the normal operation duration of the network can be extended, thus the real-time presentation of the environment conditions in chemical industry and the human safety can be ensured.

Reference

- Bauer M., Cox J.W., Caveness M.H., Downs J.J., Thornhill N.F., 2007, Finding the Direction of Disturbance Propagation in a Chemical Process Using Transfer Entropy, *IEEE Transactions on Control Systems Technology*, 15, 12-21, DOI: 10.1109/TCST.2006.883234.
- Cheng H., Tikkala V.M., Zakharov A., Myller T., Jamsa-Jounela S.L., 2011, Application of the Enhanced Dynamic Causal Digraph Method on a Three-Layer Board Machine, *IEEE Transactions on Control Systems Technology*, 19, 644-655, DOI: 10.1109/TCST.2010.2051441.
- Huang X.L., Wang G., Hu F., Kumar S., 2011, Stability-Capacity-Adaptive Routing for High-Mobility Multihop Cognitive Radio Networks, *IEEE Transactions on Vehicular Technology*, 60, 2714-2729, DOI: 10.1109/TVT.2011.2153885.
- Levy D., Diken E.G., 2010, Field Identification of Unknown Gases and Vapors Via IR Spectroscopy for Homeland Security and Defense, *IEEE Sensors Journal*, 10, 564-571, DOI: 10.1109/JSEN.2009.2038540.
- Maji P., Paul S., 2010, Rough Sets for Selection of Molecular Descriptors to Predict Biological Activity of Molecules, Part C (Applications and Reviews) *IEEE Transactions on Systems, Man, and Cybernetics*, 40, 639-648, DOI: 10.1109/TSMCC.2010.2047943.
- McLoughlin I., Zhang H., Xie Z., Song Y., Xiao W., 2015, Robust Sound Event Classification Using Deep Neural Networks, and Language Processing *IEEE/ACM Transactions on Audio, Speech*, 23, 540-552, DOI: 10.1109/TASLP.2015.2389618.

- Menzel M., Ranjan R., Wang L., Khan S.U., Chen J., 2015, CloudGenius: A Hybrid Decision Support Method for Automating the Migration of Web Application Clusters to Public Clouds, *IEEE Transactions on Computers*, 64, 1336-1348, DOI: 10.1109/TC.2014.2317188.
- Niedzinski C., Miekina A., Morawski R.Z., 2002, Algorithms for estimation of concentrations in spectrophotometric analysis of multicomponent substances, *IEEE Transactions on Instrumentation and Measurement*, 51, 1068-1072, DOI: 10.1109/TIM.2002.806015.
- Niu Y., Su L., Gao C., Li Y., Jin D., Han Z., 2016, Exploiting Device-to-Device Communications to Enhance Spatial Reuse for Popular Content Downloading in Directional mmWave Small Cells, *IEEE Transactions on Vehicular Technology*, 65, 5538-5550, DOI: 10.1109/TVT.2015.2466656.
- Park Y., Kweon I.S., 2016, Ambiguous Surface Defect Image Classification of AMOLED Displays in Smartphones, *IEEE Transactions on Industrial Informatics*, 12, 597-607, DOI: 10.1109/TII.2016.2522191.
- Reh A., Gusenbauer C., Kastner J., Gröller M.E., Heinzl C., 2013, MObjects--A Novel Method for the Visualization and Interactive Exploration of Defects in Industrial XCT Data, *IEEE Transactions on Visualization and Computer Graphics*, 19, 2906-2915, DOI: 10.1109/TVCG.2013.177.
- Rodriguez P., Biersack E.W., 2002, Dynamic parallel access to replicated content in the Internet, *IEEE/ACM Transactions on Networking*, 10, 455-465, DOI: 10.1109/TNET.2002.801413.
- Shojaeilangari S., Yau W.Y., Nandakumar K., Li J., Teoh E.K., 2015, Robust Representation and Recognition of Facial Emotions Using Extreme Sparse Learning, *IEEE Transactions on Image Processing*, 24, 2140-2152, DOI: 10.1109/TIP.2015.2416634.
- Sironi A., Türetken E., Lepetit V., Fua P., 2016, Multiscale Centerline Detection, *IEEE Transactions on Pattern Analysis and Machine Intelligence*, 38, 1327-1341, DOI: 10.1109/TPAMI.2015.2462363.
- Wang J., Barback C.V., Ta C.N., Weeks J., Gude N., Mattrey R.F., Blair S.L., Trogler W.C., Lee H., Kummel A.C., 2017, Extended Lifetime In Vivo Pulse Stimulated Ultrasound Imaging, *IEEE Transactions on Medical Imaging*, 1, DOI: 10.1109/TMI.2017.2740784.
- Wu F., Wen C., Guo Y., Wang J., Yu Y., Wang C., Li J., 2017, Rapid Localization and Extraction of Street Light Poles in Mobile LiDAR Point Clouds: A Supervoxel-Based Approach, *IEEE Transactions on Intelligent Transportation Systems*, 18, 292-305, DOI: 10.1109/TITS.2016.2565698.
- Wu J., Ye C., Sheng V.S., Zhang J., Zhao P., Cui Z., 2017, Active learning with label correlation exploration for multi-label image classification, *IET Computer Vision*, 11, 577-584, DOI: 10.1049/iet-cvi.2016.0243.
- Yuan J., 2017, Learning Building Extraction in Aerial Scenes with Convolutional Networks, *IEEE Transactions on Pattern Analysis and Machine Intelligence*, 1, DOI: 10.1109/TPAMI.2017.2750680.
- Zeng J., Chu W.S., la Torre F.D., Cohn J.F., Xiong Z., 2016, Confidence Preserving Machine for Facial Action Unit Detection, *IEEE Transactions on Image Processing*, 25, 4753-4767, DOI: 10.1109/TIP.2016.2594486.
- Zhioua G., Tabbane N., Labiod H., Tabbane S., 2015, A Fuzzy Multi-Metric QoS-Balancing Gateway Selection Algorithm in a Clustered VANET to LTE Advanced Hybrid Cellular Network, *IEEE Transactions on Vehicular Technology*, 64, 804-817, DOI: 10.1109/TVT.2014.2323693.