

# Research on the Ionized Water Decontamination and Disinfection Device Based on Single Chip Microcomputer Control

Yi Yang

Guangdong Songshan Polytechnic, Shaoguan, Guangdong 512126, China

wyuyy@163.com

In this paper, it takes ionator HOM as prototype, and puts forward innovative to research and develop a kind of ionized water decontamination and disinfection device based on single chip microcomputer control to replace the chemical detergent and disinfectant used in daily life. In system design, it adopts modular design program, takes single chip microcomputer as the core of control, and determines the schematic diagram of control of function module. In software system design, it gives independent software design to the function module according to the functional requirements realized by software, provides the block diagram of program flow, and conducts debugging and performance test by replacing the circuit board in ionator HOM with the designed circuit board of control system. It is indicated by the debugging that circuit board can work well and control generation of the needed electric signal. Simultaneously, it is known from performance test that the designed circuit board can control ionator HOM effectively and has certain germ killing efficacy.

## 1. Introduction

Traditional chemical disinfectant kills germs mainly by utilizing active chlorine and other high oxide molecules, and there are three main types of active chlorine, namely Cl<sub>2</sub> (chlorine), HOCl (hypochlorous acid) and OCl<sup>-</sup> (hypochlorous acid ion) (Squizzato et al., 2015). When adopting chemical disinfection and decontamination, it shall be easy to cause chemical contamination to the environment, and it shall have greater influence on the people and livestock. In recent years, the people attaches more and more importance to the ionized water gradually and gives extensive researches (Ji, 2014), namely that electrolysis is used in generating acidic ionized water and the acidic ionized water is used as disinfectant. However, as the traditional electrolysed water can generate negative potential alkaline ionized water and positive potential acidic ionized water simultaneously in the electrolytic process (Wang et al., 2013), while only the part of acidic water is used in disinfection, and the certain proportion of alkaline water needs to be drained, waste of the water resource shall be caused thereof (Shangguan and Li, 2013); in this way, the water consumption is great to generate the effective component – acidic ionized water, and the production efficiency is relatively lower. As the water consumption is great, it shall be needed to connect with tap water, thus the equipment is heavy and expensive, and it is inconvenient for movement (Sun, 2014). By aiming at these technical issues, US Tennant Company researches and develops the domestic portable disinfectant ionator HOM. In this paper, it gives research by aiming at the domestic portable disinfectant researched and developed by US Tennant Company, with purpose of realizing its localization and developing a portable ionized water decontamination and disinfection device based on single chip microcomputer control and available for the use of the aged and children in such occasions as family, school and office (Liu et al., 2016).

## 2. Ionized Water Preparation Principle

Ionized water is a kind of functional water, commonly known as electrolysed water, and it refers to alkaline ionized water and acidic ionized water collectively (Narayanaswamy, 2014). The preparation principle is as follows: the tap water in daily use (containing a little of NaCl) is loaded in diaphragm electrolytic cell, and water

molecules are dispersed, become smaller and are realigned in function of DC electric field via the positive and negative electrodes in electrolytic cell, thus oxidation reduction potential (ORP) of a part of water shall be in positive value (Qu et al., 2013), and that of another part of water shall be in negative value, finally acidic ionized water and alkaline ionized water could be obtained by adopting membrane separation technology (Cho et al., 2014). The ionized water generated in anode chamber contains  $H^+$  and is acidic ionized water, and there is  $Cl_2$  generated simultaneously, so it is appropriate for disinfection and beauty. The ionized water generated in cathode chamber contains  $OH^-$  and is alkaline ionized water, so it is appropriate for drinking water. Simultaneously, movement of such metal ions as  $Ca^{2+}$ ,  $Mg^{2+}$  and  $Na^{2+}$  in water towards cathode can increase the content in alkaline ionized water, and the hazardous substances dissolved in water can be eliminated by reduction, thus water quality can be promoted.

### 3. Overall Composition of the Device

#### 3.1 Characteristics of ionized water

As ionized water decontamination and disinfection device is researched and developed by taking ionator HOM as prototype, so main components of the device are same as ionator HOM and include water storage tank, electrolytic cell, water suction pump, high voltage electric field terminal, atomizing nozzle, control circuit board and power supply, etc. Block diagram of overall structure of the device is as shown in Figure 1, and various new portable equipment can be produced by giving design to overall appearance of the device.

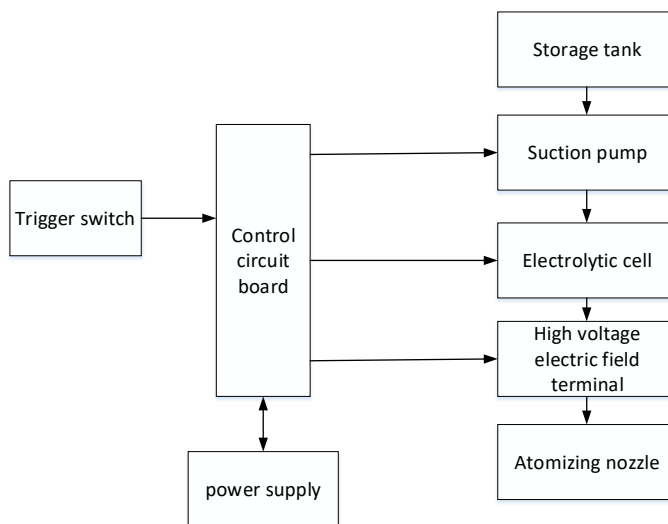

Figure 1: The overall structure of the device block diagram

#### 3.2 Main components of the device

Electrolytic cell is composed of cell body, anode and cathode, anode chamber and cathode chamber are mainly separated by diaphragm, and schematic diagram of the structure is as shown in Figure 2. Electrolytic cell can be divided into the three types of aqueous solution electrolytic cell, molten salt electrolytic cell and non-aqueous solution electrolytic cell according to the different electrolyte solutions. When applying direct current to electrolytic cell, oxidation reaction shall take place in the interface of anode and solution, and reduction reaction shall take place in the interface of cathode and solution, so as to produce the product needed.

To achieve favourable electrolytic efficiency and obtain high-quality ionized water, one needs to consider not only influence factors of the electrolytic cell itself but also electrode and diaphragm during the time of selecting electrolytic cell. It is known from research that: firstly, the different material of electrode determines the different quality of ionized water (as shown in Table 1) and the life of electrolytic cell; secondly, the larger the area of the same electrode plate is, the better the quality of the ionized water generated is (as shown in Figure 3), and the longer the electrode life is. However, the larger electrode area is not better, for the too large electrode area may increase cost on the one hand and increase volumes of cell body and engine body on the other hand.

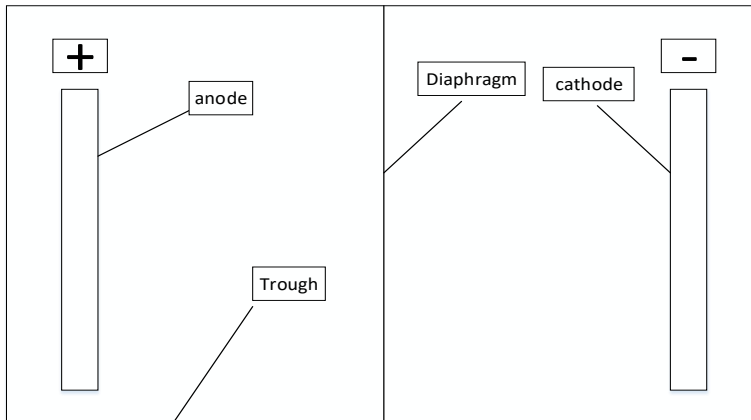

Figure 2: Schematic diagram of electrolytic cell structure

Table 1: Effect of Electrode on Ion Water Quality

Titanium electrode	Alkaline ionized water		Acid ion water	
	PH	ORP/mV	PH	ORP/mV
Imported platinum	9.3~9.4	-820	3.0~3.1	220
Domestic precious metal coating	9.0~9.1	-350	3.4~3.5	260
Homemade RIT coating	9.6~9.7	-830	3.2~3.3	250

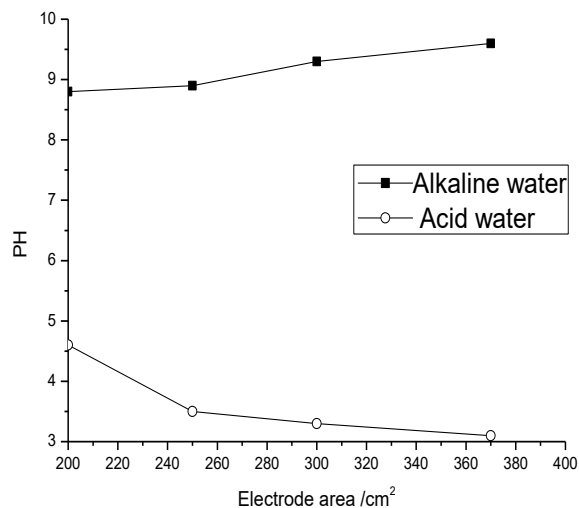

Figure 3: Effect of electrode area on pH of ionized water

### 3.3 Modular Design Program

According to overall composition of device and anti-interference problem of system, modular design is given to the control system, the principle of proximity is adopted, it is divided into the two modules of main control board module and high pressure generation board module, and one single chip microcomputer is used as core of each module. Main control board module takes charge of voltage driving of electrolytic cell, on-off of water suction pump, automatic charging of nickel-hydrogen battery pack and working state indication, etc; high pressure generation board module mainly takes charge of the generation of high pressure signal, effect on the high voltage electric field terminal, and circuit failure detection, etc. The two modules are in mutual independence, they have no data exchange, the main control board module provides the high pressure generation board module with working voltage, and functional block diagram of the concrete control system is as shown in Figure 4.

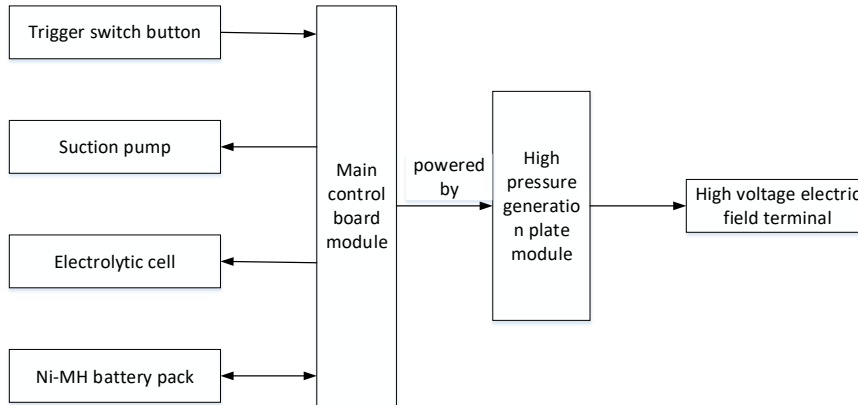

Figure 4: A block diagram of the control system

### 3.4 Selection of the Single Chip Microcomputer

The single chip microcomputer is control core of the overall system. When selecting the single chip microcomputer, one shall adhere to the general principles that functions of CPU chip should be greater than design demands slightly, design demands should be completed with hip as far as possible, and peripheral devices should be used as few as possible. Moreover, considerable investment is needed in hardware, software and personnel training for the use of processor in the majority of projects, so hardly any company should have the ability of selecting different chip for each project. Conversely, the companies are generally inclined to give specialized research on single or few serial processors. Thus, 8051 serial processor is adopted in the research of this design, and the single chip microcomputer selected by this module is the low-voltage high-performance CMOS8-bit single chip microcomputer AT89C2051 produced by ATMEL Company, the low power consumption is fit for characteristics of the battery-powered control system and can satisfy design requirements of this paper, and characteristics of the chip are as follows: working voltage 2.7V-6V; 2k-byte re-erasable flash memory, 1,000-times erasing cycle; full static operation, working frequency 0Hz-24MHz; two-stage encryption program memory, 128X8-byte internal RAM; fifteen programmable I/O port lines, two 16-bit timers/counters, six interrupt sources, programmable serial UART channel; one built-in analog comparator; low power consumption idle and power failure model.

### 3.5 Overall Program Design of the System

Analysis on the functions realized by software: functions realized by software of the control system of ionized water decontamination and disinfection device are as follows: (1) After powering on, the single chip microcomputer outputs high level signal, and water suction pump gives work. (2) It can realize output pulse control signal of the single chip microcomputer by programming according to the established model, overturn the electrolytic cell selectively and drive polarity of voltage, achieve self inverse-pole model to give power supply to the electrolytic cell, give real-time monitoring to working state of the electrolytic cell, and lighten the corresponding state indicator lamp. (3) The single chip microcomputer can output the PWM signal with working frequency 1 KHz and give effect on DC/DC converter to adjust the output electrolytic voltage, can give comparison according to the feedback voltage monitored, and can change electrolytic voltage of electrolytic cell by changing duty ratio of PWM signal and maintain the stability of electrolytic current. (4) It can realize output control signal of the single chip microcomputer by programming and synchronize the pulse signal to the switching power supply controller TPS68000 to generate the high-voltage sine-wave signal needed, give real-time monitoring to fault pin state of controller, lighten the corresponding LED indicator light, and indicate working state of the high pressure generation circuit board. (5) When voltage of the battery pack is used up, the single chip microcomputer could automatically monitor the external interrupt generated, and it might stop works of such items as water suction pump and electrolytic cell, lighten LED indicator light and remind the user of charging.

## 4. Results

Main program module is program entry, and it can initialize and mobilize various function modules. Flow block diagram of the main program module is as shown in Figure 5.

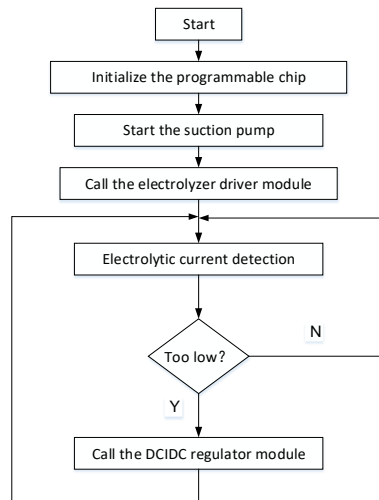

Figure 5: Main program module block diagram

It is known from hardware circuit design of the high pressure generation board module that: the single chip microcomputer STC15F100 only needs three pins to control pins SYNC, EN and FAULT of the power supply controller TPS68000 respectively, to generate sine-wave signal needed and give real-time monitoring to failure (overvoltage and overcurrent) of the whole inverter circuit. Functions realized by software design of this module are as follows: inputting the synchronous pulse signal with frequency 30KHz to SYNC pin, using EN pin in controlling the work of TPS68000, giving real-time monitoring to state of the fault pin FAULT of controller, lightening the corresponding LED indicator light, and indicating working state of the high pressure generation circuit board. Program flow block diagram of the software design of high pressure generation board module is as shown in Figure 6.

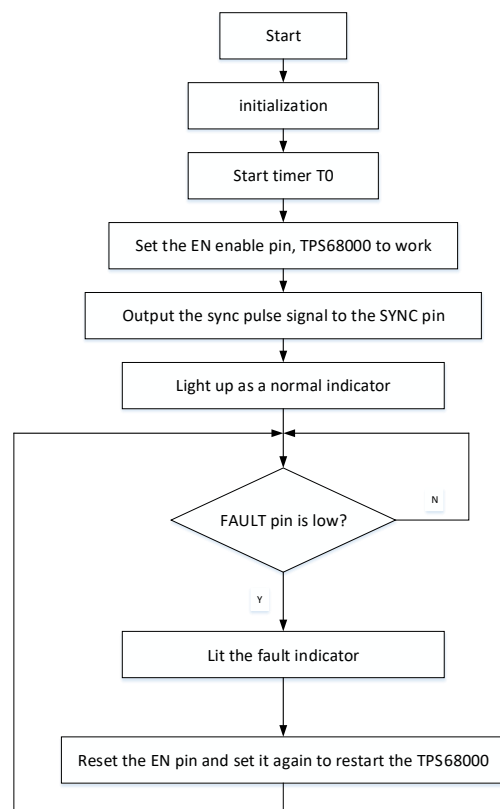

Figure 6: High pressure generation board program flow chart

To further verify the control system designed in this paper and make the ionized water decontamination and disinfection device reaching the disinfection effect with disinfection rate above 99%, the designed circuit board shall be used in replacing the cleaning disinfectant ionator HOM, and performance test shall be conducted on performance verification platform. The test results indicate that the disinfection rate could reach 90% at 6s after giving spraying treatment to *Escherichia coli* DH52 and *Staphylococcus aureus* BY4743.

## 5. Conclusion

The control system design in this paper can realize the favourable disinfection effect of control device, while the overall performance is not as good as the control system of the cleaning disinfectant ionator HOM, so circuit of the control system of this device needs to be improved and optimized further.

## Reference

- Cho K., Qu Y., Kwon D., Zhang H., Cid C.A., Aryanfar A., Hoffmann M.R., 2014, Effects of anodic potential and chloride ion on overall reactivity in electrochemical reactors designed for solar-powered wastewater treatment, *Environmental science & technology*, 48, 4, 2377-2384, DOI: 10.1021/es404137u
- Ji L., 2014, Control System Design Based on MSP430 Microcontroller, *Advanced Materials Research*, Trans Tech Publications, 1030, 1438-1441, DOI: 10.4028/www.scientific.net/amr.1030-1032.1438
- Liu B., Su H., Wang S., Zhang Z., Liang Y., Yuan D., Ma J., 2016, Automated determination of nitrite in aqueous samples with an improved integrated flow loop analyzer, *Sensors and Actuators B: Chemical*, 237, 710-714, DOI: 10.1016/j.snb.2016.07.002
- Narayanaswamy V., 2014, A review of thermal and humidity management needs and feasible solutions for next generation subsea electric systems, *Underwater Technology*, 32(2), 129-143, DOI: 10.3723/ut.32.129
- Qu Y., Aryanfar A., Cid C., Zhang H., Hoffmann M.R., 2013, A Self-Contained, PV-Powered Toilet and Domestic Waste Water Disinfection System, *Proceedings of the Water Environment Federation*, 2013, 2, 257-262, DOI: 10.2175/193864713813503701
- Shangguan E., Li Q., 2013, A pre-anodized inlaying ultrathin carbon paste electrode for simultaneous determination of uric acid and folic acid, *Electrochimica Acta*, 89, 600-606, DOI: 10.1016/j.electacta.2012.11.073
- Squizzato A.L., Fernandes D.M., Sousa R.M., Cunha R.R., Serqueira D.S., Richter E M., Muñoz R A., 2015, Eucalyptus pulp as an adsorbent for biodiesel purification, *Cellulose*, 22, 2, 1263-1274, DOI: 10.1007/s10570-015-0557-7
- Sun X.Y., 2014, The Design of Automatic Control System for Greenhouse Based on Microcontroller, *Applied Mechanics and Materials*, Trans Tech Publications, 446, 1188-1192, DOI: 10.4028/www.scientific.net/amm.446-447.1188
- Wang J., Li J., Shangguan E., Li Q., 2013, Simultaneous determination of ascorbic acid and acetaminophen at the pre-anodized inlaying ultrathin carbon paste electrode, *Analytical Methods*, 5(16), 4119-4125, DOI: 10.1039/c3ay40813b