

Charge transport and electrochemical reaction in porous composite electrodes for solid oxide fuel cells

Antonio Bertei¹, Nicolaos Vatisas¹, Antonio Barbucci², Massimo Viviani³,
Cristiano Nicolella^{1*}

¹Dipartimento di Ingegneria Chimica, Chimica Industriale e Scienza dei Materiali,
Università di Pisa, Via Diotisalvi 2, 56100 Pisa, Italy.

²Dipartimento di Ingegneria Chimica e Processo, Università di Genova, P.le J.F.
Kennedy, 16129 Genova, Italy.

³Istituto per l'Energetica e le Interfasi, CNR, Via De Marini, 6, 16149, Genova, Italy.
*c.nicolella@ing.unipi.it

This paper presents a mathematical model of mass and charge transport and electrochemical reaction in porous composite cathodes for application in solid oxide fuel cells. The model describes a porous composite cathode as a continuum, and characterises charge and mass transfer and electrochemical kinetics using effective parameters (i.e. conductivity, diffusivity, exchange current) related to morphology and material properties by percolation theory.

The model accounts for the distribution of morphological properties (i.e. porosity, tortuosity, density of contacts among particles) along cathode thickness, as experimentally observed on scanning electron microscope images of LSM/YSZ cathodes of varying thickness. This feature allows the model to reproduce the dependence of polarisation resistance on thickness, as determined by impedance spectroscopy on LSM/YSZ cathodes of varying thickness. Polarisation resistance in these cathodes is almost constant for thin cathodes (up to 10 μm thickness), it sharply decreases for intermediate thickness, to reach a minimum value for about 50 μm thickness, then it slightly increases in thicker cathodes.

The model is validated using experimental data, with a single adjustable parameter (compression factor) related to estimated tortuosity of ion-conducting paths in the cathode. Model simulations are used to define a design parameter, which allows a rough estimate of minimum polarisation resistance as a function of cathode design (thickness), material properties (density of active contacts, effective resistivity), kinetic parameters (exchange current) and operating conditions (temperature).

1. Introduction

Most of the energy losses in a hydrogen SOFC occur in the cathode, a random porous structure composed of electron-conducting particles (e.g. strontium-doped lanthanum manganite, LSM) and ion-conducting particles (e.g. yttria-stabilised zirconia, YSZ) (Kenjo et al., 1991). Oxygen reduction by electron transfer from the electrocatalyst to

form oxygen ions is the electrochemical process which takes place in a SOFC cathode. Porous composite cathodes have a complex morphology. Even if all relevant transport and kinetic parameters of elementary transport and electrochemical reaction events at the boundaries between two particles were known, predicting how the interplay of material properties and geometry (i.e. porosity, particle size, electrode thickness) affects cathode performance is often a demanding task. Recently, several aspects of property-performance relationships have been theoretically discussed at different levels of sophistication (Fleig, 2003). Despite crude simplifications, the continuum electrode approach - which models the porous composite structure of SOFC electrodes as a continuum phase characterised by effective transport and kinetic parameters (i.e. electronic conductivity, ionic conductivity, electrochemical reaction constants, gas diffusivity) - yields valuable results. This approach has been employed in several simulation studies of composite electrodes (Costamagna et al., 1998; Kenney and Karan, 2007). The crucial task in modelling porous composite structures as continuum phases is to relate effective transport and kinetic parameters to geometrical and structural parameters. Effective conductivities of electron-conducting and ion-conducting phases are proportional to conductivities of the materials used in the composite and depend on the exact shape of the network formed by conducting particles. Percolation theory can be employed to determine the corresponding proportionality factor (Schneider et al., 2007).

In addition to the microstructure, electrode thickness also affects the pathway taken by species participating in the electrochemical reaction. Polarisation resistance in porous composite cathodes is reported to decrease with increasing cathode thickness (Kenjo et al., 1991; Juhl et al., 1996), because of the increased number of available active reaction sites, until ohmic losses become dominant and limit the overall process rate, due to the increasing length of conduction pathways. In LSM/YSZ porous composite cathodes experimentally characterised in a recent paper over a wide range of operating temperatures (800-900 °C) (Barbucci et al., 2009), polarisation resistance is almost constant in thin cathodes (with less than 10 μm thickness), it decreases in the intermediate range of thickness up to a minimum value observed at around 50 μm , then increases for thicker cathodes. This behaviour cannot be predicted using assumptions commonly adopted for modelling porous composite cathodes. To give insight to the results reported by Barbucci et al. (2009), this paper reports on theoretical investigations based on i) experimental observations on the distribution of morphological properties along the thickness of porous composite cathodes, and ii) a continuum approach to model SOFC porous composite cathodes accounting for variations of morphological properties along cathode thickness.

2. Mathematical modelling

A porous composite cathode is made of electron-conducting particles and ion-conducting particles, randomly distributed and sintered to give enough porosity for molecular oxygen diffusion (see Figure 1). Electrochemical oxygen reduction occurs close to the contact surface between electron-conducting particles and ion-conducting particles, where electrons can be dispatched from the electronic collector through the electron-conducting phase, transferred to oxygen to produce ions, which are constantly

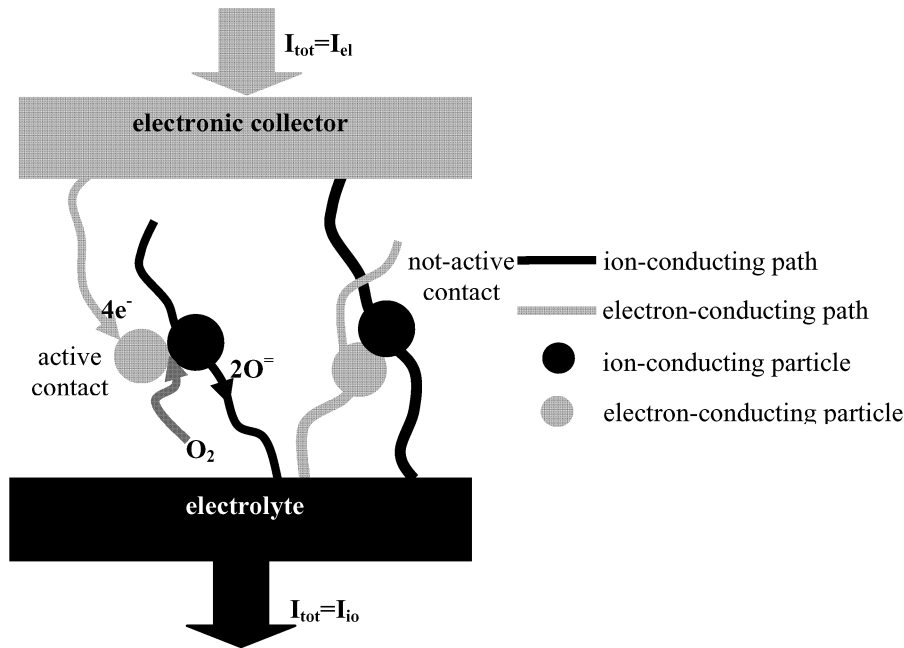

Figure 1 - Schematic view of a porous composite.

carried away along the ion-conducting phase to the electrolyte (see Figure 1). The electrochemical reaction (i.e. the electron transfer from the electron-conducting phase to oxygen) can be hosted at any point of contact between an electron-conducting particle and an ion-conducting-particle, provided that the gas phase surrounds the contact point, and that the three phases (electron-conducting, ion-conducting and gas phase) are connected either with external sources of reactants (i.e. molecular oxygen from air and electrons from the electronic collector) or with sinks of products (i.e. oxygen ions to the electrolyte). During migration and transfer along the mixed percolative paths of connected electron-conducting particles and ion-conducting particles, electrical charges are subject to three types of resistance:

- ohmic resistance along the electronic paths, determined by both structural properties (i.e. density and tortuosity of electron-conducting paths) and material properties (i.e. resistivity of the electron-conducting phase);
- activation resistance to electron transfer, determined by both structural properties (i.e. density of active contacts between electron-conducting particles and ion-conducting particles), and electrochemical reaction mechanisms and kinetics;
- ohmic resistance along the ionic paths, determined by both structural properties (density and tortuosity of the ion-conducting paths) and material properties (resistivity of the ion-conducting phase).

In addition, the overall process of charge migration and transfer may be retarded by molecular oxygen diffusion in the pores. Each of these four resistances contributes to determining the overall polarisation resistance of a SOFC cathode.

Variations of polarisation resistance experimentally observed for different cathode thicknesses cannot be predicted when assuming uniform morphological properties of cathode materials (Barbucci et al., 2009). The mathematical model presented in this work to give insight into these experimental results is based on several assumptions, as detailed in a recent paper (Nicoletta et al., 2009).

Under these assumptions, charge transport and electrochemical reaction in a composite cathode can be described through the set of model equations summarised in Table 1.

Table 1 - Model equations

Charge continuity	$\frac{di_{el}}{dz} = -n_v j_{tr}$	$\frac{di_{io}}{dz} = n_v j_{tr}$
Ohm law	$\frac{dV_{el}}{dz} = -\rho_{el} \tau_{el}^r i_{el}$	$\frac{dV_{io}}{dz} = -\rho_{io} \tau_{io}^r i_{io}$
Kinetics	$j_{tr} = j_0 \left(\exp\left(\alpha \frac{F}{R_g T} \eta\right) - \exp\left(- (1-\alpha) \frac{F}{R_g T} \eta\right) \right)$	
Overpotential	$\eta = [V_{el}(z) - V_{io}(z)] - [V_{el}^{eq} - V_{io}^{eq}]$	
Polarisation resistance	$\eta_c = [V_{el}(0) - V_{io}(\delta)] - [V_{el}^{eq} - V_{io}^{eq}]$	$R_p = \frac{\eta_c}{i_{tot}}$
Boundary conditions	$z = 0 \rightarrow i_{el} = i_{tot} ; i_{io} = 0$	$z = \delta \rightarrow i_{el} = 0 ; i_{io} = i_{tot}$

3. Results and discussion

The mathematical model of a porous composite cathode developed in this work was tested using experimental data presented in a companion paper (Barbucci et al., 2009) on polarisation resistance obtained by impedance spectroscopy on cathodes of different thicknesses operated at temperatures within 600 – 850 °C range. Experimental results are compared with model simulations in Figure 2, where calculated and measured polarisation resistance is plotted as a function of cathode thickness for operating temperatures of 600, 700 and 800 °C. As can be observed in this figure, the model accurately reproduces the behaviour observed in the experiments over a wide range of operating conditions. In particular, the model predicts higher polarisation resistance for cathodes with thickness greater than the one corresponding to minimum resistance. This behaviour cannot be described when the whole cathode volume is assumed to have uniform morphological properties. The proposed model can reproduce the experimental results on the dependence of polarisation resistance on cathode thickness, because it takes non-uniform morphological properties into account.

Cathodic processes in SOFCs discussed above can be quantitatively described using model simulations. Figure 3 shows the overpotential calculated as a function of axial position in three cathodes of 11, 26 and 51 µm, respectively. The overpotential is distributed over the whole thickness of the cathodes thinner than 26 µm, which are

therefore active for electrochemical reaction throughout their volume, while part of the thickest cathode (51 μm) is not used for electrochemical reaction.

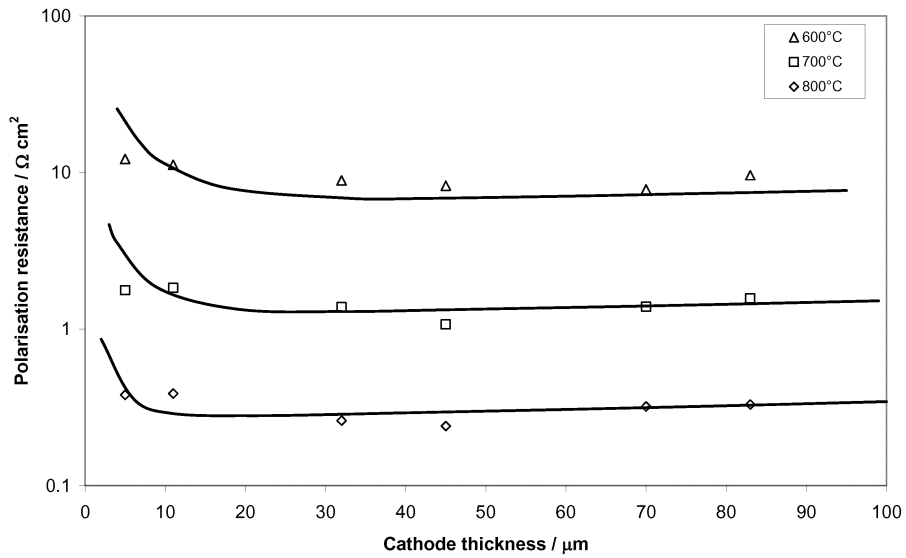

Figure 2 - Model validation with experimental data on polarisation resistance in cathodes of different thicknesses.

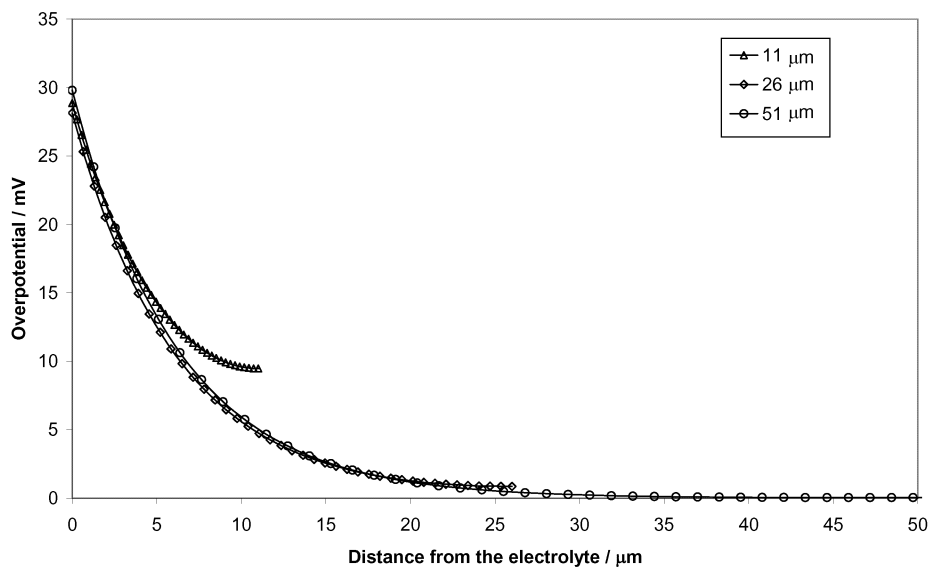

Figure 3 - Overpotential distribution in cathodes of different thicknesses.

The overpotential in this cathode is similar to that in the thinner cathode (26 μm), confirming that the active volume is the same in both cases. The unused part of the thicker cathode only serves as a bridge for the delivery of electrons to the active volume. The thinnest cathode (11 μm) has a higher overpotential than the other cathodes. This is because of the limited number of active reaction sites in the former, compared to the latter, which results in higher current per single contact for any imposed overall current. As a consequence, according to the Butler-Volmer kinetics, a higher overpotential between the electron-conducting phase and the ion-conducting phase is required for electron transfer.

4. Conclusions

A mathematical model of electrochemical reaction and charge transport in porous composite cathodes for SOFCs was developed to give insight into experimental data on polarisation resistance in cathodes of different thicknesses. The model takes account of variations of cathode morphological properties, as observed on SEM pictures of cathodes with different thicknesses. The model is validated using experimental data, with a single adjustable parameter (compression factor) related to estimated tortuosity of ion-conducting paths in the cathode. Model simulations are used to define a design parameter, which allows a rough estimate of minimum polarisation resistance as a function of cathode design (thickness), material properties (density of active contacts, effective resistivity), kinetic parameters (exchange current) and operating conditions (temperature).

References

- Barbucci A., Carpanese P., Viviani M., Vatistas. N. and Nicoletta C., 2009, *J. Appl. Electroch.* 39, 513-521.
- Costamagna P., Costa P. and Antonucci V., 1998, *Electrochimica Acta* 43, 375-394.
- Fleig J., 2003, *Annu. Rev. Mater. Res.* 33, 361-382.
- Juhl M., Primdahl S., Manon C. and Mogensen M., 1996, *J. Power Sources* 61, 173-181.
- Kenjo T., Osawa S. and Fujikawa K., 1991, *J. Electrochem. Soc.* 138, 349-355.
- Kenney B. and Karan K., 2007, *Solid State Ionics* 178, 297-306.
- Nicoletta C., Bertei A., Viviani M. and Barbucci A., 2009, *J. Appl. Electroch.* 39, 503-511.
- Schneider L.C.R., Martin C.L., Bultel Y., Dessemond L. and Bouvard D., 2007, *Electrochim. Acta* 52, 3190-3198.