

Rigorous Optimisation of Refinery Hydrogen Networks

Nan Jia, Matthew Loughrey, Nan Zhang*

Centre for Process Integration, School of Chemical Engineering and Analytical Science,
The University of Manchester, Manchester, M60 1QD, UK
Nan.Zhang@manchester.ac.uk

Heavier crude oil, tighter environmental regulations and increased heavy-end upgrading in the petroleum industry are leading to the increased demand for hydrogen in oil refineries. Hence, Hydrotreating and Hydrocracking processes now play increasingly important roles in modern refineries. Refinery hydrogen networks are becoming more and more complicated as well. Therefore, optimisation of overall hydrogen networks is required to improve the hydrogen utilisation in oil refineries. Previous work over hydrogen management has developed methodologies for H₂ network optimisation. However there are considerable limitations affecting the quality of optimisation. To overcome the drawbacks in previous work, a new rigorous modelling and optimisation approach has been developed. Light-hydrocarbon production and integrated flash calculation have been incorporated into a hydrogen consumer model. NLP and SA optimisation methods are tested. A case study is carried out to demonstrate the effectiveness of the developed approach.

1. Introduction

Hydrogen is vital for oil refiners to face the trends caused by the clean fuel regulations, increased processing of heavier sour crude and heavy end upgrading. Hydrogen demand is increasing in the refinery as more hydrogen is needed for the deeper hydrodesulphurisation to reduce the sulphur content in fuels and more hydrotreating is needed to achieve high cetane diesel. Hydrocracking can play an important role in heavy end conversion because of its considerable flexibility and high quality of the products. This indicates that more hydrogen is needed to satisfy the requirement. The overall hydrogen network management is then required in order to make best use of hydrogen resources to meet new demands and improve profitability.

Various methodologies have been developed over the years to improve the hydrogen utilization in oil refineries. Alves (1999) developed a graphical approach named as hydrogen pinch analysis, which can effectively identify minimum hydrogen consumption with limited network information. Based on the target set by the hydrogen pinch analysis, Liu (2002, 2005) developed an automated design method using mathematical programming. Then Zhang, et. al. (2008) developed an iterative approach to consider the impact of impurities in the system, such as light hydrocarbons. As we

are moving towards more detailed modelling and optimisation of refinery hydrogen networks, more accurate modelling and faster solution methods need to be developed.

2. Rigorous hydrogen network modelling

With concerns of impurities and integrated flash calculation, a rigorous hydrogen consumer model is built, based on which the overall hydrogen network modelling is accomplished as well.

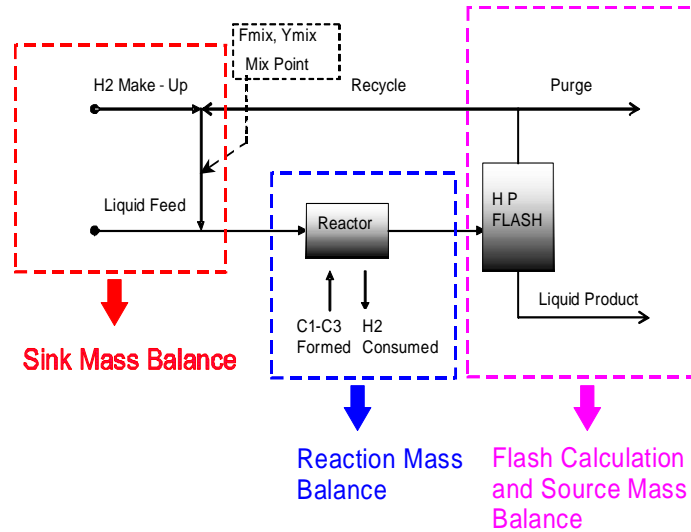

Figure 1 Hydrogen consumer model

Hydrogen flow and composition at the mix point are fixed to maintain the H2/Oil ratio and partial pressure at the reactor inlet.

2.1 Multi-components consideration

The improved model was constructed based on rigorous multi-component concern with the consideration of all impurities within each stream including light hydrogen carbon yield.

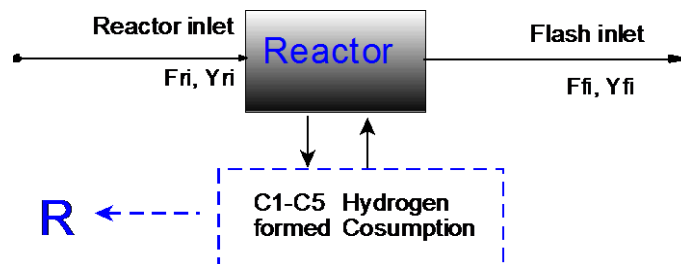

Figure 2 Reactor model

- Reactor inlet mass balance: $F_{fi} = F_{mix} + F_{feed}$
 $F_{fi} * Y_{fi} = F_{mix} * Y_{mix} + F_{feed} * Y_{feed}$
- Reaction Modelling: $F_{fi} = F_{ri} - R$

Where R is defined as the quantities of the light hydrocarbon formed and hydrogen consumed, F and Y stands for flowrate and purity, and mix means Flowrate or purity at mix point. The outlet of the reactor is also the inlet of the flash.

Light hydrocarbon (mostly C1 to C5) production in hydroprocessing reaction is typically 1 wt% to 4 wt% and this will definitely affect the purity of hydrogen recycle and purge within a hydrogen consumer unit. However the light hydrocarbon production was neglected in previous work. Therefore the improved hydrogen consumer model has taken into account it to improve accuracy of the modelling to get more realistic and convinced hydrogen consumer model.

2.2 Integrated flash calculation

The flash calculation is also integrated into the optimisation step. This is mainly because that optimisation alone without flash calculation cannot generate realistic solutions, In addition, Iterative procedure by Singh (2006) is difficult to converge and extremely time consuming. Hence the integrated flash calculation is then introduced. Vapour liquid equilibrium constants, known as K-values, are also assumed as constants during iterations to speed up the calculations without affecting the quality of the optimisation.

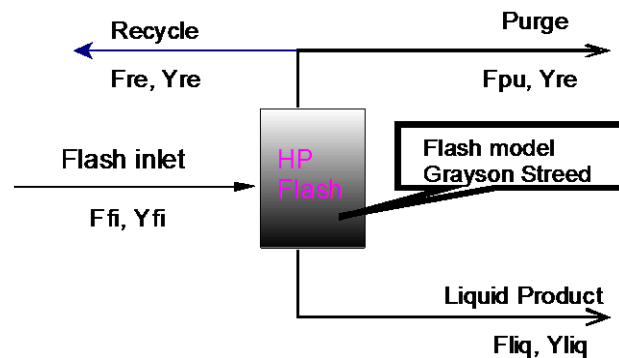

Figure 3 Flash model

- Flash mass balance: $F_{fi} = F_{re} + F_{pu} + F_{liq}$
 $F_{fi} \cdot Y_{fi} = F_{re} \cdot Y_{re} + F_{pu} \cdot Y_{re} + F_{liq} \cdot Y_{liq}$
- Reaction Modelling: $Y_{re} = Y_{liq} \cdot K\text{-value}$

A key assumption for this model is that constant K-values are used in each optimisation step. The K-values are initially set from rigorous correlations then it will be checked by using simulation when optimisation is obtained.

3. Hydrogen network optimisation framework

Step 1: Hydrogen pinch analysis for base case

Check for possibility and scope for improvement for optimising the network using hydrogen surplus diagram

Step 2: Integrated hydrogen network optimisation

NLP or SA methodology will be chosen as the optimisation engine Multi-component consideration is applied all over the network.

Step 3: Solution simulation

The optimised hydrogen network will be simulated to check for material balance. Constant K-values will also be checked.

Step 4: Feasibility check

The hydrogen consumers in the optimised hydrogen distribution network should have a hydrogen-to-oil ratio, hydrogen partial pressure kept within acceptable ranges.

4. Case study

4.1 Base case and hydrogen pinch analysis

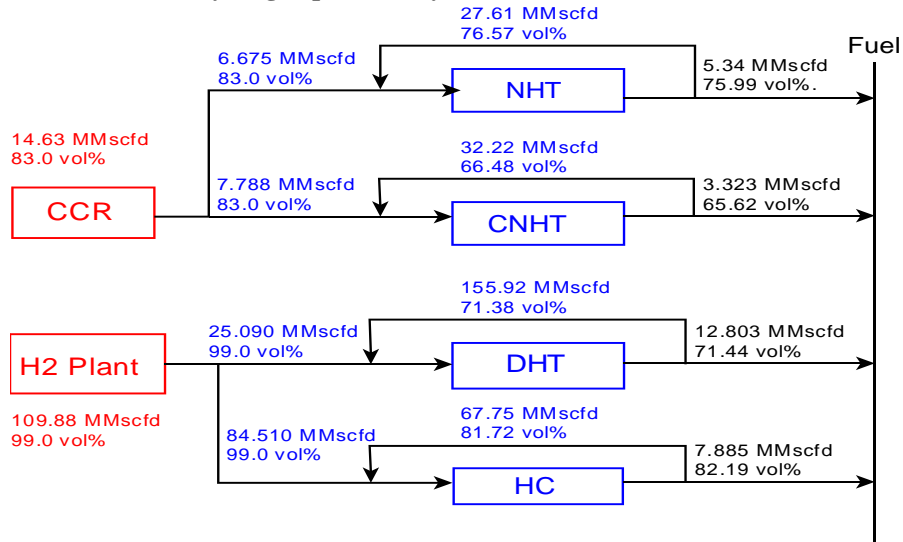

Figure 4 Hydrogen network base case

Before applying optimisation, it is required to scope for the current network potentials beforehand so hydrogen pinch analysis would be the first step of the whole optimisation work.

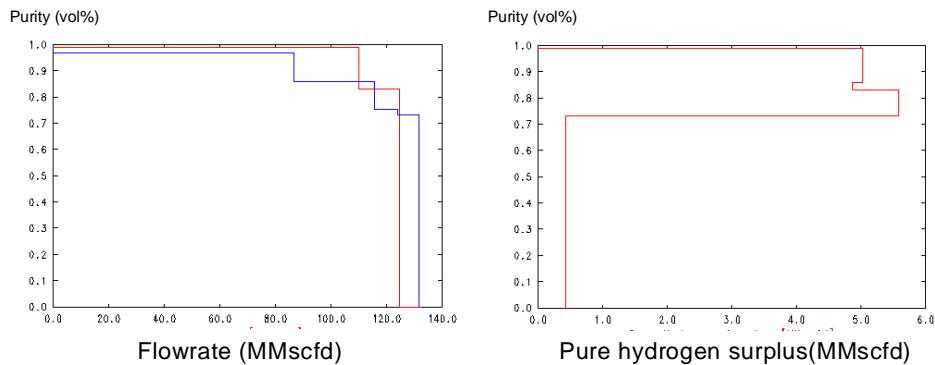

Figure 5 Hydrogen Composite Curve and Surplus Curve

4.2 NLP H2 network optimisation

- Variables: Flowrates and purities of H2 streams around the hydrogen network (the H2 flowrate and purity at the mix point are fixed to maintain the reactor inlet condition)
- Parameters: liquid feed stream flowrates and purities
- Objective: minimum hydrogen plant production

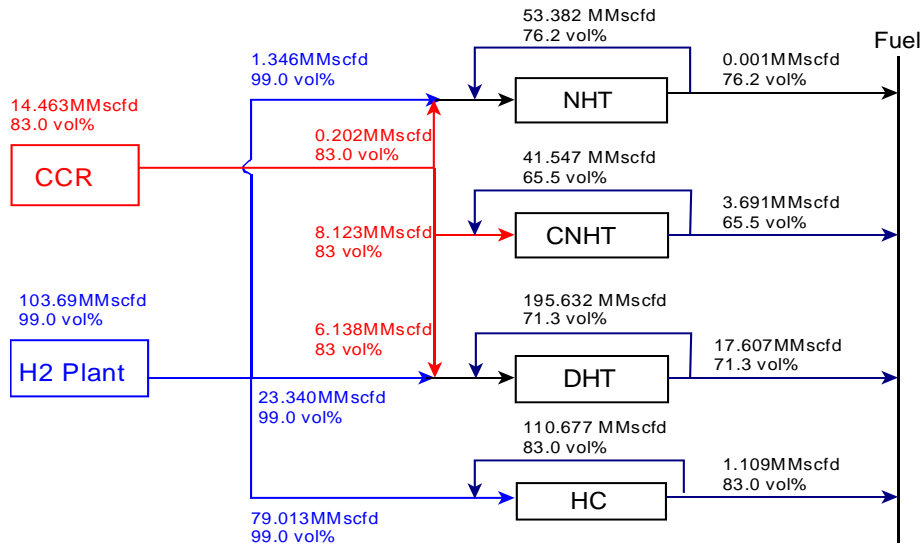

Figure 6 Optimised hydrogen network using NLP

The optimum solution shows that the Hydrogen production of hydrogen plant has been reduced from 109.88 MMscfd down to 103.69 MMscfd. The optimisation saved 6.19 MMscfd of hydrogen.

4.3 Simulated annealing H2 network optimisation

The SA moves for hydrogen network optimisation can be flow changes including recycle and flow between units and these moves will allow the exploration of convergence on an optimal solution through increasing or decreasing the changes of the probabilities of the two types of flow changes.

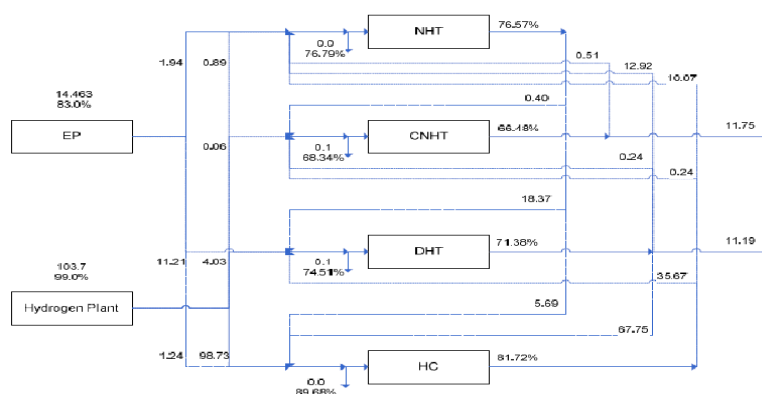

Figure 7 Optimised hydrogen network using SA

The SA optimum solution shows 6.18MMscfd hydrogen saving from H2 plant. The minimum hydrogen plant requirement was reduced from 109.88 MMscfd to 103.7 MMscfd which is the same as GAMS.

4.4 Methodology comparison

Table 1 Methodology comparison

Methodology	NLP using GAMS	Simulated annealing
Minimum hydrogen generated	103.69	103.7
New connections introduced	2	11
CPU run time	10-20 s	10-11 h
Solution complexity	easy	Difficult
Extension mixed integer problems	limited	Flexible

The two methods both performed well and with almost the same optimum output. GAMS introduced 2 new connections while SA used 11 new connections bringing complexity to the new design which may affect the quality of the retrofit. GAMS has huge advantage over cpu run time, a few seconds compared with 10 h by SA. However SA would be more flexible than GAMS and is more adaptable to different types of problem.

5. Conclusions

SA and NLP using GAMS both work well with the multi-component cases and generate good results. GAMS optimisation is fast in speed but with limited ability to cope with complicated problems, for example MINLP problems. Simulated annealing is much lower however with great flexibility Methodology selection would be depending on the type of problem after all.

References:

- Alves, J., 1999, Analysis and design of refinery hydrogen distribution systems, PhD thesis, Department of Process Integration, UMIST, Manchester, UK
- Cassidy, B. and Pandit, H., 2001, Hydrogen: Under New Management. Hydrocarbon Engineering, 2001, 1-3.
- Hallale, N. and Liu, F., 2001, Refinery hydrogen management for clean fuels production, Advances in Environmental Research, 6, 81-98
- Liu, F., 2002, Hydrogen integration in oil refineries, PhD thesis, Department of Process Integration, UMIST, Manchester, UK.
- Singh, B.B., 2006, Bi-linear data reconciliation and Rigorous optimisation of refinery hydrogen network with hydrogen plant, 21st Process Integration Research Consortium, The University of Manchester, UK.
- Zhang, N., Singh, B.B. and Liu, F., 2008, Rigorous simulation and optimisation for refinery hydrogen management, 11th Conference on Process Integration, Modelling and Optimisation for Energy Saving and Pollution Reduction PRES 2008, Prague, Czech Republic