

Dynamic Modeling and Parameter Estimation of a Cu/Ni Roasting Section

Mirnes Alic¹, Tor Anders Hauge^{2,3}, Bernt Lie*¹

¹Telemark University College
N-3918 Porsgrunn, Norway, Bernt.Lie@hit.no

²Xstrata Nikkelverk
N-4606 Kristiansand, Norway

³University of Agder
N-4898 Grimstad, Norway

As one of the most important part of a pyrometallurgical process line, the roasting section represents a challenging section to optimize and control. The present work focuses on the development of the model that is describing a transient behavior of the roasting section which consists of the following sequentially connected components: roasters, cyclones, electrostatic precipitators and fans. The roasting section is modeled from the first principles, setting up the conservation laws for mass, momentum and energy. To complete the model, parameter estimation based on the least squares estimates is performed. Important variables of the process such as concentration, pressure and temperature are extracted from the model and compared with the measurements in the roasting section of Xstrata Nikkelverk Kristiansand. The model is intended for use in an operator training simulator and for control purposes.

1. Introduction

Roasting often represents an initial phase in a pyrometallurgical process, and in the same time the most complex one. Several authors have been interested in the problem of modeling the process of nickel smelting and off-gas treatment from the electric furnaces (Kirschen et al., 2006). Significant work has been done on modeling of the pressure behavior of an industrial roaster off-gas system with the aim of providing insights into pressure control and gas leakage minimization (Shang et al., 2007). Similar work has been done to investigate the effects of pressure and temperature on concentrations of SO₂ of a smelter furnace and converter off-gas system (Shang et al., 2008). In order to analyze and optimize the control of the complete off-gas system of a smelter process (C.B. de Araujo, 2009), it is important to have a representable model of the same. This paper focuses on the modeling of roasting section of Xstrata Nikkelverk Kristiansand, where the gases and metal fumes are produced in the process of roasting metal ores in fluidized bed roasters. Important variables of the system at hand are pressure, temperature and concentration of oxygen. Modeling the transient behavior of these variables is the main objective of this work. Dynamic behavior of the system is described by mechanistic models of units based on the conservation laws of mass, momentum and energy. The developed model is intended for use in operator training simulator and for control purposes.

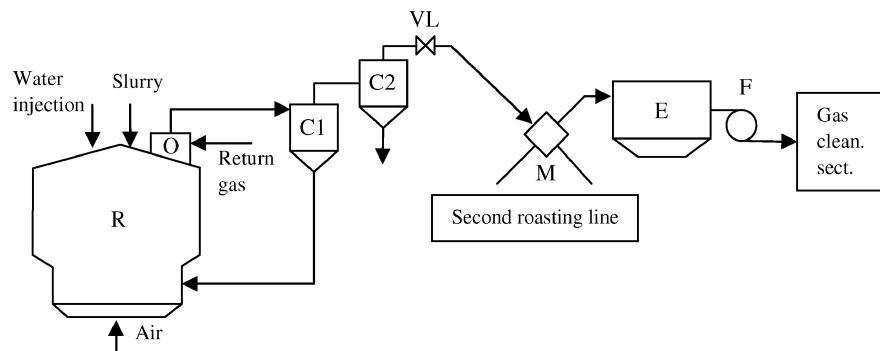

Figure 1: Roasting section

2. Process description

An intermediate product from the Ni production at Xstrata Nickelverk is slurry consisting of metal sulfides. The processing of this intermediate copper/nickel product begins with the roasting of the metal sulfides in fluidized bed roasters (R) (see Fig. 1). In a series of reactions inside the roaster, metal sulfides are converted to metal oxides accompanied by a substantial release of gases and dust which need to be treated. The resulting gas stream is rich in sulphur dioxide and it is used in later stages for sulphuric acid production. For a gas to be suitable for the sulphuric acid production, it needs to be cleaned from all dust particles, moisture content and metal fumes. The gas stream coming out of the roaster (ca. 880°C) is mixed with a certain amount of cold gas from a cleaning section in order to reduce the gas stream temperature and protect the downstream equipment. This takes place in the upper part of the roaster (O). Cooled dust-laden gas enters a series of cyclones (C1 and C2) where by gravitational and rotational forces, separation of coarse solids and gas takes place. Separated solids from the first cyclone are recycled back into the roaster. In the real process to insure continuous production and higher capacity, it is common to have two parallel roasting lines. In this paper, only one line is considered assuming that the same modeling approach can be applied for the other one. After the cyclones and the control valve (VL), the two gas stream lines meet in a pipeline intersection denoted as the manifold (M). Here, an exchange in mass and heat between two gas lines happens rather quickly. The most important function of the manifold is to provide a way to balance the pressures in the system as well as to provide the means of bypassing one or the other line for the purpose of maintenance (for example a discharge of accumulated dust in subsequent equipment). After the manifold, the gas stream enters a unit for fine particles removal i.e. the electrostatic precipitator (E). In the electrostatic precipitator, fine particles are removed in such a way that as they flow with the gas in between a set of electrodes, they are being electrostatically charged and transported by a negative electric

field towards the grounded plates. There, fines accumulate and are later discharged. The driving force for the fluid movement through the equipment is a negative pressure provided by the induced fans (F). After the fans, the gas stream ideally is free of coarse and fine particles and contains only metallic fumes, water vapor and gas components. At the end of the roasting section, the gas enters the cleaning section for further treatment, and finally ends in the production plant of sulphuric acid.

3. Model development

To develop a nonlinear dynamic model of the system, the first principles of mass, momentum and energy conservation are used. Developing a mechanistic model has some advantages over other types of models; an important one being maintaining physical meaning of its variables and parameters.

3.1 Assumptions

In order to simplify the modeling process, the following assumptions are introduced: potential energy is neglected as we consider gas medium at low height difference, shock effects in the pipes are not considered as well the kinetic energy of the gas, the pipes cross-sections are considered constant, and the equipment is not considered in the spatial terms. The properties of the gas are approximated by the ideal gas law.

3.2 Model equations

From the energy balance of a closed volume, one obtains an expression for the dynamic temperature change as given in Eq. (1):

$$\frac{p_i V_i}{T_i} \left(\frac{c_{p,i}}{R_m} - 1 \right) \frac{dT_i}{dt} = \dot{m}_{i-1} c_{p,i} (T_{i-1} - T_i) + R_m T_i (\dot{m}_{i-1} - \dot{m}_i) - \dot{Q}_i \quad (1)$$

where: p is pressure, T is temperature, V is volume, R_m is gas constant, c_p is specific heat capacity, \dot{m} is mass flow, \dot{Q}_i is heat exchanged with the surroundings. From the ideal gas law and Eq. (1), one can deduce following expression (Eq. (2)) for the pressure change in the closed volume:

$$V_i \left(\frac{c_{p,i}}{R_m} - 1 \right) \frac{dp_i}{dt} = \dot{m}_{i-1} c_{p,i} T_{i-1} - \dot{m}_i c_{p,i} T_i - \dot{Q}_i \quad (2)$$

Mass flow change for each unit is deduced from the momentum balance of the unit taking into consideration downstream flow resistance due to friction in the pipes and local flow resistance, and it is given by Eq. (3):

$$L_{i+1} \frac{d\dot{m}_i}{dt} = (p_i - p_{i+1}) a_{i+1} - k_{i+1} \dot{m}_i^n \quad (3)$$

where: k is coefficient of frictional resistance, a is cross-sectional area, L is pipe length, and exponent $n = \{1, 2\}$. For the equipment that has relatively small volume, the model for pressure drop takes static form as given by Eq. (4):

$$p_i = p_{i+1} + \frac{k_{i+1} \dot{m}_i^n}{a_{i+1}} \quad (4)$$

with a negligible change in temperature ($T_i = T_{i-1}$) and mass flow ($m_i = m_{i-1}$). Equations (1), (2) and (3) are used to describe transient behaviour of the following units: O, C1, C2 and E, while Eq. (4) is used for VL and M. The index i refers to the sequence of units presented on Fig. 1 from left to right. The model of the roaster (R) is somewhat more complicated. The roaster is split into two volumes: freeboard (F) and bed (B). The equations for the pressure, temperature and concentration of the roaster follow below. The roaster bed temperature is given by Eq. (5):

$$\begin{aligned} \epsilon_{ib} m_b c_{p,b} \frac{dT_b}{dt} = & \dot{m}_{sl}^s c_{p,s} (T_{sl} - T_b) + \dot{m}_a^s c_{p,a} (T_a - T_b) \\ & + \alpha \dot{m}_{sl}^w [c_{p,sl} (T_{sl} - T_{bo}) - H_{vap} + c_{p,wg} (T_{bo} - T_b)] + \eta_r \dot{m}_{sl}^s H_r \end{aligned} \quad (5)$$

where: m_b is bed mass, H_r is heat of reaction, H_{vap} is heat of vaporization, a , sl , bo , s , g , l , w stand for air, slurry, boiling point, solid, gas, liquid, and water, respectively. Pressure and temperature in the freeboard follow the same principle as shown in Eq. (1) and (2). Pressure is given by Eq. (6):

$$\begin{aligned} V_f \left(\frac{c_{p,g}}{R_m} - 1 \right) \frac{dp_f}{dt} = & \dot{m}_a c_{p,a} T_b + \dot{m}_{sl}^w c_{p,wg} T_f - \dot{m}_f c_{p,f} T_f \\ & + (1 - \alpha) \dot{m}_{sl}^w [c_{p,sl} (T_{sl} - T_{bo}) - H_{vap} + c_{p,wg} (T_{bo} - T_f)] \end{aligned} \quad (6)$$

Temperature in the freeboard is given by Eq. (7):

$$\begin{aligned} \frac{p_f V_f}{T_f} \left(\frac{c_{p,g}}{R_m} - 1 \right) \frac{dT_f}{dt} = & \dot{m}_a c_{p,a} (T_b - T_f) + R_m T_f (\dot{m}_a + \dot{m}_{sl}^w - \dot{m}_f) \\ & + (1 - \alpha) \dot{m}_{sl}^w [c_{p,sl} (T_{sl} - T_{bo}) - H_{vap} + c_{p,wg} (T_{bo} - T_f)] \end{aligned} \quad (7)$$

Finally, the concentration of oxygen in the freeboard of the roaster is given by Eq. (8):

$$\frac{dc_{O_2}}{dt} = \frac{u_0 A_i}{V_f} c_{O_2, in} - \frac{u_0 A_i}{V_f} c_{O_2} - K_r c_{O_2} \quad (8)$$

where: c is concentration, u_0 is superficial velocity, A_i area, V_f volume, K_r rate of reaction. The model is now complete and system of equations consists of 16 ordinary differential equations and 6 steady state equations for VL and M. For the completion of the system of equations, it is necessary to estimate the frictional resistance coefficients. This is made by finding the steady states of the system and performing the least square estimation.

4. Simulation and validation

To confirm the validity of the model, steady state overall system pressure distribution is presented in Fig. 2 where one can observe the gradual pressure increase from the electrostatic precipitator towards the roaster. On the right side of Fig. 2 concentration of

oxygen in the freeboard is presented as the result of metal sulfides conversion in the bed and partially in the freeboard of the roaster. Figure 3 shows the predicted temperatures in the roaster bed and the cyclone 1 compared with the measurements. From the Fig. 3 (left) the difficulty of attaining the exact match is evident and the reasons for such behaviour could be various. The inaccuracies in the roaster model have effect on the model predictions of the equipment that comes next downstream (Fig. 3 (right)). One of the reasons that could cause such fluctuations in the roaster is the composition of feed slurry. Here, we primarily think of water amount in the slurry and added water for control purpose. Simple sensitivity analysis has shown that the model is very sensitive to changes in the slurry water percent.

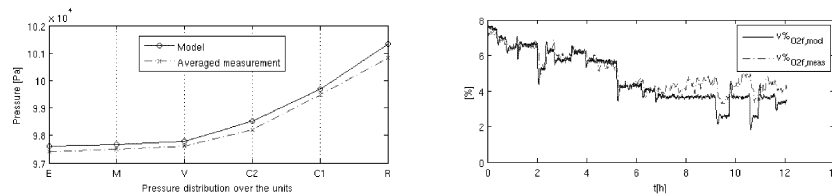

Figure 2: Pressure distribution over the system (left); Concentration of oxygen in the freeboard (right)

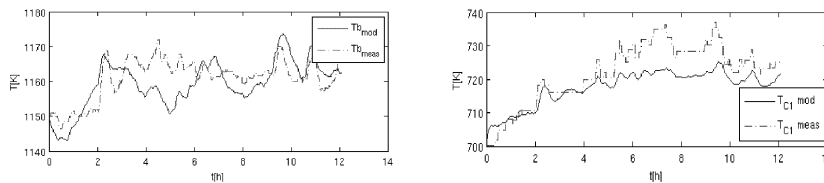

Figure 3: Temperature evolution in the bed of the roaster (left); Temperature evolution in the cyclone 1 (right)

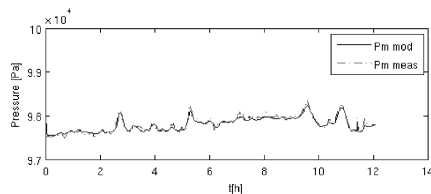

Figure 4: Pressure evolution in the manifold

As for the pressure of individual units in the system, Fig. 4 shows a rather good match of the model prediction and the measurement in the junction of the two gas streams (M).

5. Conclusions

In this paper a nonlinear dynamic model of roaster section is presented. The model has been developed based on the first principles of mass, momentum and energy conservation. To validate and analyze the model, several comparisons have been given. The comparisons have shown a good fit of the model to the measurements at this particular regime of work. It should be noted that the model for the roaster is rather sensitive to the composition of the slurry with regards to the heat of reaction. The model will be further studied and improved for training simulator and control purposes.

6. Acknowledgement

The authors gratefully acknowledge financial support of Xstrata Nikkelverk and appreciate professional support from Ole Morten Dotterud, Øyvind Ommundsen and Finn Stålesen from Xstrata Nikkelverk.

References

- C.B. de Araujo A., Brito P.R. and Shang H., 2009, Mitigation of energy intensity of an industrial off-gas cleaning system using process engineering solutions, *Journal of Cleaner Production*, 17, 1512-1525
- Kirschen M., Velikorodov V. and Pfeifer H., 2006, Mathematical modelling of heat transfer in dedusting plants and comparison to off-gas measurements at electric arc furnaces, *Energy*, 31, 2590
- Shang H., Dillabough M., Nelson, P., and Salt, B., 2008, Dynamic modelling of an industrial smelter furnace and converter off-gas system, *American Journal of Environmental Sciences*, 4, 22-30
- Shang H., Mehta B., Thwaites P., Ryan L. and Nelson P., 2007, Dynamic modeling of an industrial roaster off-gas system in a Nickel smelter, *Industrial and Engineering Chemistry Research*, 46, 5371-5379