



Integrated Bioethanol Separation and Dehydration in a Novel Extractive DWC

Radu M. Ignat^{a,b}, Anton A. Kiss^{*a}

^a AkzoNobel – Research, Development & Innovation, Process Technology ECG, Zutphenseweg 10, 7418 AJ, Deventer, The Netherlands,

^b University “Politehnica” of Bucharest, Dpt of Chemical Engineering, Polizu 1-7, 011061 Bucharest, Romania. tony.kiss@akzonobel.com

This study proposes an innovative distillation setup – based on a novel extractive dividing-wall column (E-DWC) – that is able to concentrate and dehydrate bioethanol in a single step, by integrating all units of the conventional sequence into only one distillation column. In this work, a mixture of 10 %wt ethanol (100 ktpy plant) is concentrated and dehydrated using ethylene glycol as mass separating agent. Rigorous simulations were carried out in Aspen Plus, and for a fair comparison all alternatives were optimized using the reliable sequential quadratic programming (SQP) method. The results show that energy savings of 17 % and a similar decrease in CapEx, are possible for the novel E-DWC alternative, while using a significantly reduced footprint as compared to the conventional separation process.

1. Introduction

Bioethanol is one of the most promising and sustainable biofuel alternatives to fossil fuels, being readily usable in the existing car engines and conveniently distributed within the current infrastructure. The present industrial scale bioethanol production relies on several processes, such as: corn-to-bioethanol, sugarcane-to-bioethanol, basic and integrated lignocellulosic biomass to ethanol (Balat et al., 2008). All these processes have one common feature, namely the production of diluted bioethanol – in the range of 5-12 %wt bioethanol – that needs to be further concentrated up to 99-99.8 %wt according to the current international standards (ASTM D 4806 and EN 15376). Due to the presence of the binary azeotrope ethanol-water (95.63 %wt ethanol), several steps are required in order to reach the purity target. Typically, the first step involves the bioethanol pre-concentration from 5-12 % up to 92.4-94 %wt, while in the second step the bioethanol is dehydrated up to higher concentrations – above the composition of the binary azeotrope – by using a mass separating agent (MSA) or solvent. These steps are carried out in a conventional sequence of three distillation columns (Figure 1 left) – pre-concentration distillation column (PDC), extractive distillation column (EDC) and solvent recovery column (SRC) – with high energy penalties and large investment cost. A solution to overcome the high energy demands of conventional distillation is using advanced process intensification and integration techniques, such as thermally coupled distillation columns or dividing-wall columns (DWC). Notably, DWC is one of the best examples of proven process intensification technology in distillation, as it allows significantly lower investment and operating costs while also reducing the equipment and carbon footprint. Remarkable, the DWC technology is not limited to ternary separations alone, but it can be used also in azeotropic separations (Kiss and Suszwalak, 2012; Sun et al., 2011), extractive distillation (Bravo-Bravo et al., 2010), and even reactive distillation (Mueller and Kenig, 2007; Kiss et al., 2009; Hernandez et al., 2009; Kiss et al., 2012; Kiss and Suszwalak, 2012).

Please cite this article as: Ignat R. M. and Kiss A. A., (2012), Integrated bioethanol separation and dehydration in a novel extractive DWC, Chemical Engineering Transactions, 29, 619-624

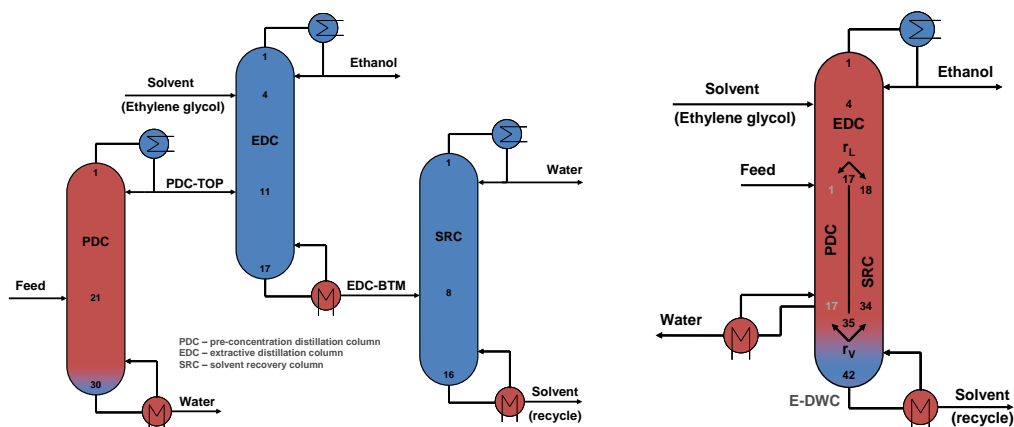

Figure 1. Conventional sequence (left) and E-DWC alternative (right) for the bioethanol pre-concentration and dehydration by extractive distillation.

Recent studies proposed the use of DWC for azeotropic and extractive distillation of ethanol (Kiss and Suszwalak, 2012; Sun et al., 2011), but they were limited only to the dehydration step, leaving out the pre-concentration stage of the process, which is in fact the most energy intensive. This study proposes an innovative distillation setup (Figure 1 right) – based on a novel extractive DWC – that is able to concentrate and dehydrate bioethanol in a single step, by integrating all units of the conventional sequence into only one distillation column. Rigorous simulations were carried out in Aspen Plus. Both alternatives considered here were optimized using the sequential quadratic programming (SQP) method in terms of minimum energy requirements with constraints on products purities and recovery.

2. Problem statement

For the use as fuel or additive, bioethanol must have a purity of min. 99-99.8 %wt, according to the current international standards (EN 15376, ASTM D 4806). Due to the presence of the binary azeotrope ethanol-water (95.63 %wt ethanol), several steps are required in order to reach the purity target, which implies very high energy penalties and large investment costs. Considering the high demand of bioethanol, novel improved alternatives are needed to reduce these costs. To solve this problem, we propose here a novel extractive dividing-wall column (E-DWC) that is able to perform all separation and dehydration steps in only one distillation unit. This integrated unit allows significant energy savings and reduction of investment costs, while using a much reduced footprint as compared to the conventional separation process.

3. Results and discussion

Aspen Plus simulations were performed using the rigorous RADFRAC unit with RateSep (rate-based) model. NRTL property method was used due to the presence of a non-ideal mixture containing polar components (Black and Ditsler, 1974; Kotai et al., 2007). The feed stream considered here is the diluted ethanol stream (10 %wt) obtained by fermentation. The production rate is 100 ktpy bioethanol. Both conventional and E-DWC alternatives described hereafter were optimized in terms of minimal energy demand using the state of the art sequential quadratic programming (SQP) method available in Aspen Plus (Bartholomew-Biggs, 2008, Boggs and Tolle, 1995).

3.1 Conventional distillation sequence

The conventional sequence presented in Figure 1 (left) consists of three distillation units: pre-concentration distillation column (PDC), extractive distillation column (EDC) and solvent recovery column (SRC) – 3 column shells, 3 condensers and 3 reboilers in total. The first column (PDC) in the sequence has the function to separate water as bottom stream and a near-azeotropic composition mixture as distillate – sent afterward to the second column (EDC).

Table 1. Design parameters of an optimal conventional sequence for bioethanol separation.

Design parameters	PDC	EDC	SRC	Unit
Total number of stages	30	17	16	–
Feed stage number	21	11	8	–
Feed stage of extractive solvent	–	4	–	–
Column diameter	3.4	1.5	0.9	m
Operating pressure	1	1	1	bar
Feed composition (mass fraction)				
Ethanol : water	0.1 : 0.9	0.935 : 0.065	–	kg/kg
Water : solvent	–	–	0.039 : 0.961	kg/kg
Reflux ratio	2.9	0.17	0.6	kg/kg
Reboiler duty	23,882	5,574	1,454	kW
Condenser duty	-13,626	-3,440	-865	kW
Ethanol recovery	–	99.94	–	%
Solvent (EG) recovery	–	–	99.91	%
Purity of bioethanol product	–	99.80	–	%wt
Purity of water by-product	99.99	–	98.6	%wt
Purity of ethylene glycol recycle	–	–	99.99	%wt

In the EDC unit, ethylene glycol – used as a high boiling solvent – is added on a stage higher than the feed stage of the ethanol-water mixture. Due to the presence of the EG solvent the relative volatility of ethanol-water is changed such that their separation becomes possible. Pure bioethanol is collected as top distillate product of the EDC, while the bottom product contains only solvent and water. The solvent is then completely recovered in the bottom of the third column (SRC), cooled and then recycled back to the extractive distillation column. An additional water stream is obtained as distillate of the SRC unit. Table 1 lists the key design and process parameters of the optimized conventional flowsheet. Figure 2 presents the temperature and composition profiles along the three distillation columns.

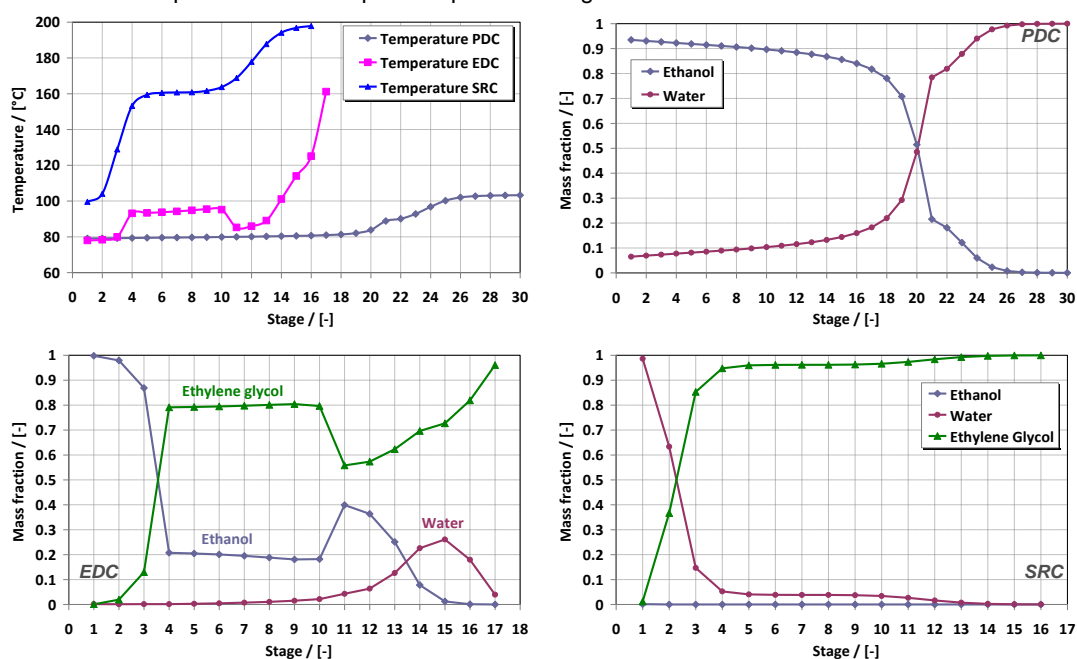

Figure 2. Temperature and composition profiles along the distillation columns (PDC, EDC and SRC) of the conventional sequence

3.2 Extractive dividing-wall column

Since all the distillation columns of the conventional separation sequence (Figure 1 left) operate at atmospheric pressure, the use of a DWC was explored as an attractive alternative. Figure 1 (right) shows the conceptual design of the proposed E-DWC that combines three distillation units into just one column. In this column, the feed side (prefractionator) acts as the PDC unit of the conventional sequence. Water is removed as liquid side stream, but an additional side reboiler is required in order to return the required amount of water vapors to the column. The liquid feed stream is fed on top of the prefractionator side, thus serving as a reflux to the PDC section. The vapor leaving the feed side of the E-DWC has a near azeotropic composition. Solvent is added at the top of the E-DWC, this section acting in fact as the EDC unit of the conventional sequence. Ethanol is separated here as high purity top distillate, and removed as the main product. The liquid flowing down the top section (EDC) is collected and distributed only to the (SRC) side opposite to the feed side (prefractionator) and further down the bottom of the E-DWC. This complete redistribution of the liquid flow is required in order to avoid the presence and loss of solvent on the feed side (PDC section). In the SRC section, the solvent is separated as bottom product and then recycled in the process.

It is worth noting that the vapor coming from the bottom of the E-DWC to the bottom of the dividing-wall consists mainly of water. However, this amount is not sufficient for the PDC section, thus the requirement for an additional side reboiler. The key parameters of the optimal design are presented in Table 2. In contrast to the well-known DWC configuration (Dejanović et al., 2010; Yildirim et al., 2011), the side stream is collected here from the same (feed) side of the column, not the opposite. Figure 3 plots the temperature as well as the liquid composition profiles in the E-DWC. Remarkable, the temperature difference between the two sides of the wall is very low (less than 20 °C) – such conditions being easily implemented in the practical application (Dejanović et al., 2010). It is also worth noting that the diameter of the E-DWC unit is only slightly lower than the diameter of the PDC unit of the conventional sequence, although it does require some additional stages. In practice, this means that the revamping of existing plants is possible by re-using the existing PDC unit (i.e. add more stages by extending the height of the column or by using a more efficient structured packing).

Table 2. Design and process parameters of an optimal optimized E-DWC

Design parameters	Value	Unit
Total number of stages	42	–
Number of stages pre-fractionator side	17	–
Feed stage on pre-fractionator side	1	–
Feed stage of extractive solvent (main column side)	4	–
Side stream withdrawal stage	17	–
Wall position (from - to stage)	18-34	–
Column diameter	3.35	m
Operating pressure	1	bar
Feed stream flowrate (mass)	125000	kg/hr
Solvent flow rate (mass)	20793	kg/hr
Feed composition (mass fraction)		
Ethanol : water	0.1 : 0.9	kg/kg
Feed stream temperature	30	°C
Reflux ratio	3.4	kg / kg
Liquid split ratio (r_L)	0 : 1	kg / kg
Vapor split ratio (r_V)	0.4 : 0.6	kg / kg
Total reboiler duty (side reboiler and bottom reboiler)	25775	kW
Condenser duty	-12964	kW
Ethanol recovery	99.81	%
Water recovery	99.99	%
Purity of bioethanol product	99.81/ 99.60	%wt / %mol
Purity of water by-product	99.80/ 99.90	%wt / %mol
Purity of ethylene glycol recycle	99.99/ 99.99	%wt / %mol

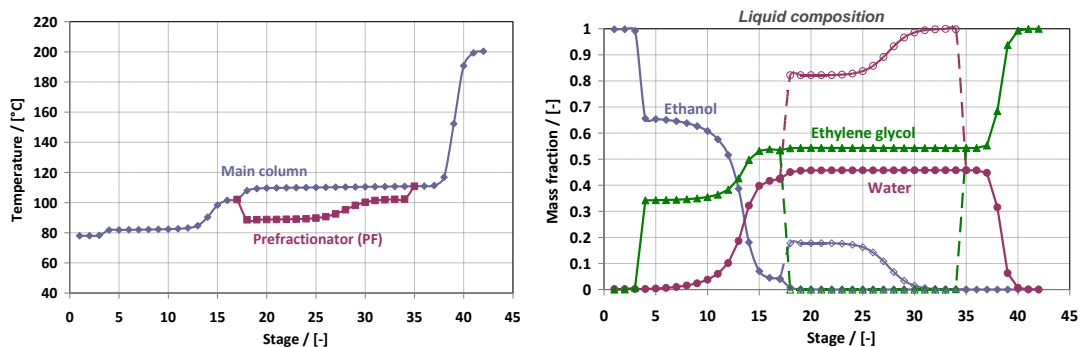

Figure 3. Temperature and composition profiles in the E-DWC (dotted line means the prefractionator or the feed section of the column)

3.3 Process comparison

The total investment costs (TIC), total operating costs (TOC) and total annual costs (TAC) were calculated in order to perform a fair comparison of the two process alternatives. The equipment costs are estimated using correlations, as described by Dejanović et al. (2011). Table 3 provides a head-to-head comparison of the key performance economic indicators, while Figure 4 conveniently illustrates the costs of the two processes considered. Remarkable, the E-DWC alternative is the most efficient in terms of energy requirements allowing energy savings of 17% while also being the least expensive in terms of capital investment and operating costs, leading to 17% lower total annual costs.

The emissions of carbon dioxide – industrially relevant to the carbon credits – were calculated here according to previously reported methods (Kiss and Suszwalak, 2012). Table 3 also lists the specific amount of CO₂ emissions per ton of bioethanol. As these emissions are closely linked to the amount of energy required, the E-DWC alternative is again in pole position with the lowest carbon footprint.

Table 3. Head-to-head comparison of the conventional sequence vs E-DWC alternative

Key performance indicators	Conventional	E-DWC alternative	Savings
Total investment cost (TIC)	k\$ 4,410	k\$ 3,626	17.8 %
Total operating costs (TOC)	k\$ 6,446	k\$ 5,355	16.9 %
Total annual costs (TAC)	k\$ 6,887	k\$ 5,718	17.0 %
Energy requirements (kW·h/ton bioethanol)	2470	2070	16.5 %
CO ₂ emissions (kg CO ₂ /h·ton bioethanol)	345.77	288.31	16.6 %

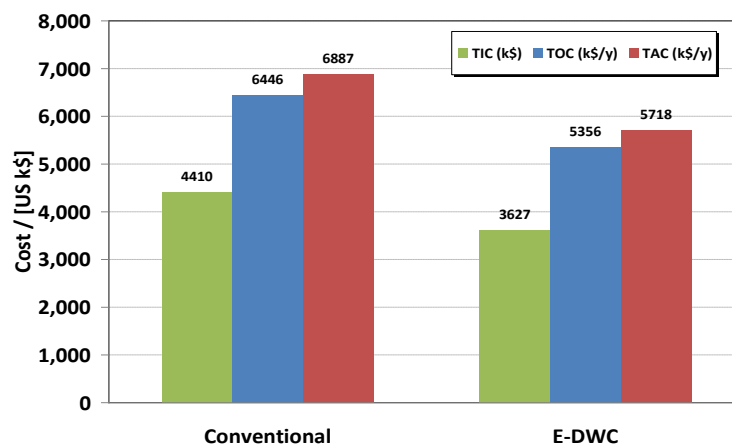

Figure 4. Comparison of conventional and DWC alternatives in terms of key performance indicators: total investment, operating and annual costs

4. Conclusions

The novel extractive DWC configuration proposed in this study combines in an efficient way all columns of a conventional separation sequence (pre-concentration column, extractive distillation column and solvent recovery column) into only one distillation unit allowing the separation of high purity bioethanol fuel – over 99.8 %wt, thus matching all international standards (EN 15376, ASTM D 4806). Remarkable, only one column shell is used in combination with one condenser and two reboilers, thus sparing also one reboiler and two condensers, as compared to the conventional separation configuration. The innovative extractive DWC distillation setup is not only technically feasible but also very attractive economically, leading to significant overall energy savings of 17%, and a similar reduction of the total investment and total annual costs. Considering the innovative results of this study, the use of an extractive DWC unit for ethanol concentration and dehydration is particularly interesting in case of building new large scale bioethanol plants. Nevertheless, the revamping of existing plants is also possible by re-using existing pre-concentration distillation columns of similar diameter (e.g. adding more stages by extending the height of the column or by using a more efficient structured packing).

Acknowledgments

The support given by AkzoNobel to Radu Ignat (Politehnica University of Bucharest) during his PhD internship, as well as the financial support from the Sector Operational Program Human Resources Development 2007-2013 of the Romanian Ministry of Labor, Family and Social Protection through the Financial Agreement POSDRU/88/1.5/S/61178 are gratefully acknowledged.

References

- Balat M., Balat H., Oz C., 2008, Progress in bioethanol processing, *Progress in Energy and Combustion Science*, 34, 551-573.
- Bartholomew-Biggs M., 2008, *Nonlinear optimization with engineering applications*, Springer Optimization and Its Applications, 19, 1-14.
- Black C., Ditsler D.E., 1974, Dehydration of aqueous ethanol mixtures by extractive distillation, *Advances in Chemistry*, 115, 1-15.
- Boggs P. T., Tolle J. W., 1995, Sequential quadratic programming, *Acta Numerica*, 4, 1-51.
- Bravo-Bravo C., Segovia-Hernández J.G., Gutiérrez-Antonio C., Duran A.L., Bonilla-Petriciolet A., Briones-Ramírez A., 2010, Extractive dividing wall column: Design and optimization, *Industrial & Engineering Chemistry Research*, 49, 3672-3688.
- Dejanović I., Matijašević L., Olujić Ž., 2010, Dividing wall column - A breakthrough towards sustainable distilling, *Chemical Engineering and Processing*, 49, 559-580.
- Hernandez S., Sandoval-Vergara R., Barroso-Munoz F. O., Murrieta-Duenasa R., Hernandez-Escoto H., Segovia-Hernandez J. G., Rico-Ramirez V., 2009, Reactive dividing wall distillation columns: Simulation and implementation in a pilot plant, *Chemical Engineering & Processing*, 48, 250-258.
- Kiss A. A., Pragt H., van Strien C., 2009, Reactive Dividing-Wall Columns - How to get more with less resources?, *Chemical Engineering Communications*, 196, 1366-1374.
- Kiss A. A., Segovia-Hernandez J. G., Bildea C. S., Miranda-Galindo E. Y., Hernandez S., 2012, Reactive DWC leading the way to FAME and fortune, *Fuel*, 95, 352-359.
- Kiss A. A., Suszwalak D. J-P. C., 2012, Enhanced bioethanol dehydration by extractive and azeotropic distillation in dividing-wall columns, *Separation & Purification Technology*, 86, 70-78.
- Kotai B., Lang P., Modla G., 2007, Batch extractive distillation as a hybrid process: separation of minimum boiling azeotropes, *Chemical Engineering Science*, 62, 6816-6826.
- Mueller I., Kenig E. Y., 2007, Reactive distillation in a Dividing Wall Column – rate-based modeling and simulation, *Industrial & Engineering Chemistry Research*, 46, 3709-3719.
- Sun L. Y., Chang X. W., Qi C. X., Li Q. S., 2011, Implementation of ethanol dehydration using dividing-wall heterogeneous azeotropic distillation column, *Separation Science and Technology*, 46, 1365-1375.
- Yildirim O., Kiss A. A., Kenig E. Y., 2011, Dividing wall columns in chemical process industry: A review on current activities, *Separation and Purification Technology*, 80, 403-417.