



# New Examples for a Novel Approach for Including Multi Phase Flows into Pinch Analysis

Pekka Ruohonen

Pöyry Finland Oy, Performance and Measurement services, Tekniikantie 4 D, P.O.Box 2, FI-02151, Finland  
[pekka.ruohonen@poyry.com](mailto:pekka.ruohonen@poyry.com)

Traditionally, pinch analysis assumes a complete freedom of design when it comes to connecting different streams with each other. The characteristics of the streams, such as heat capacity flow and the start and target temperatures, are treated as constant, regardless of the chosen match. However, if the hot flows have a composition of different components, of which some have a condensation temperature on the range in question, this assumption does not always hold. For streams like this, the end temperature and the total enthalpy given by the stream are dependent on the stream on the other side of the heat exchanger and a simple temperature difference is not sufficient to describe the situation. Typical examples of streams of this kind are moist air and other mixtures of several gases.

In this paper, the previously presented novel approach for including multi phase flows into pinch analysis will be studied further using a set of new examples. The examples include a theoretical simplified analysis to highlight the significance of the novel approach, and a discussion of the importance of the findings in industrial examples.

The results show that the methodology gives new insight to the relevant possibilities for heat recovery from multi phase streams.

## 1. Introduction

The basic idea of pinch analysis is to investigate what is the theoretical minimum for utility consumption on a chosen minimum temperature difference ( $\Delta T_{\min}$ ) when all the heating and cooling demands of the plant are taken into consideration (Linnhoff et al., 1994). However, if the hot flows taken into the analysis have a composition of different components, of which some have a saturation temperature within the same range, the basic assumption of freedom to choose matches in the pinch analysis does not always hold. For streams like this, the end temperature and the total enthalpy given by the stream are dependent on the stream on the other side and a simple temperature difference is not sufficient to describe the situation. Typical examples of streams of this kind are moist air and other mixtures of several gases. In this paper we study the possibilities of a novel pinch-based approach for estimation of heat recovery possibilities (Ruohonen and Sivill, 2011) based on the use of advanced composite curves in combination with thermodynamic simulation.

### 1.1 Advanced composite curves

Advanced composite curves (Nordman and Berntsson, 2009a) are a pinch-based method that is developed especially for retrofit situations. The advanced curves take into account the existing heat exchanger network at the mill. Therefore, it is possible to estimate with good precision how costly it will be to improve the heat exchanger network. There are four curves above pinch and four curves below. The curves above are: Hot Utility Curve (HUC), Actual Heat Load Curve (AHL), Extreme Heat Load

Curve (EHLC), and Theoretical Heat Load Curve (THLC). The corresponding curves below pinch are: Cold Utility Curve (CUC), Actual Cooling load Curve (ACLC), Extreme Cooling Load Curve (ECLC), and Theoretical Cooling Load Curve (TCLC)

The EHLC and THLC show the limits for temperature levels of possible heat exchange in the heat exchanger network. Therefore AHLC should always be between them. If AHLC is close to THLC, it means that the design is originally poor, heaters are placed on low temperature levels and thus more heat exchanger area is installed than would be necessary. In a retrofit case this is usually beneficial because this area might be useful when located somewhere else, and replacing heaters placed low usually requires a smaller number of matches to be changed. Therefore AHLC lying close to THLC is an indication of a relatively cost-effective retrofit and AHLC lying close to EHLC is an indication of a relatively expensive retrofit. A more comprehensive description of the method can be found in (Nordman and Berntsson, 2009a). The methodology has been used in two case studies considering chemical pulping (Nordman and Berntsson 2009b) and in three articles considering mechanical pulping (Ruohonen and Ahtila, 2009; Ruohonen and Ahtila, 2010; Ruohonen et al., 2010).

### 1.2 Motivation

The importance of the approach is shown in Figure 1. The Figure presents a warm and moist air exhaust flow that can be used for heat recovery. The actual end temperature of the flow, and the amount of heat that can be recovered depend strongly on the inlet temperature (shown on the x-axis) of the flow on the other side of the heat exchanger. The difference between the low and high points of the thermal duty in the case in question is 35 %. It is clear that taking the flow into the analysis by simply guessing the final outlet temperature is not a satisfactory solution.

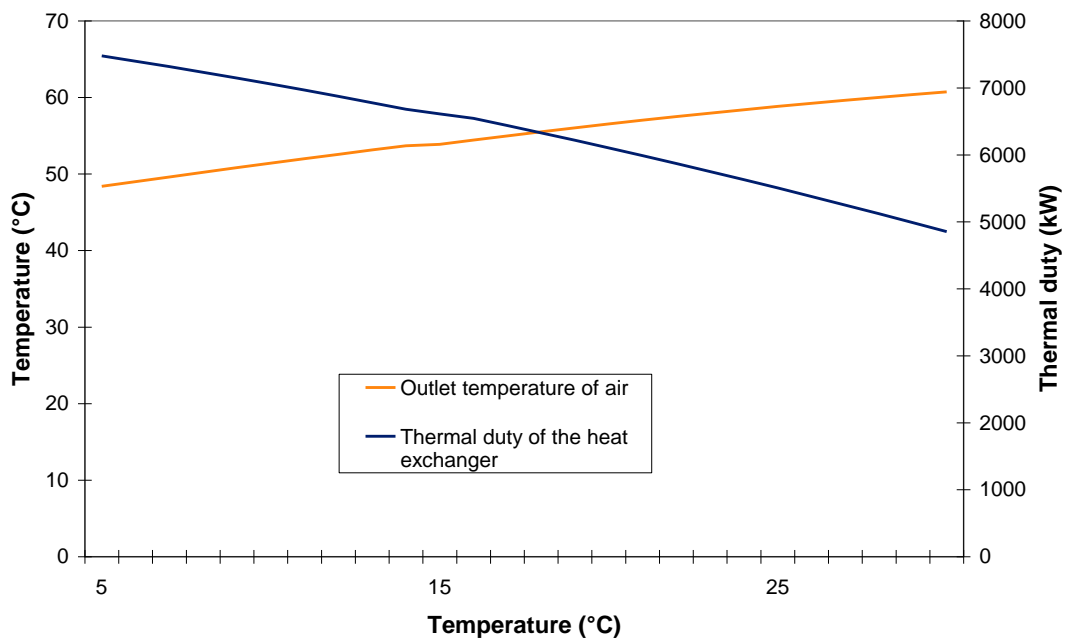

Figure 1: The effect of the temperature of incoming cold water to the outlet temperature of the exhaust air and to the thermal duty of the heat exchanger.

The problem can be tackled manually, such as in (Ruohonen and Ahtila, 2011), or it can be assumed that the heat recovery will stay unmodified, such as in (Ruohonen and Ahtila, 2011), or it can simply be guessed that the temperature of the exhaust stream will reach the temperature of the environment. None of these methods can be seen as very satisfactory and, therefore, a more systematic approach is needed.

## 2. Methodology

The methodology for estimating the possibilities for heat recovery from multi phase flows (Ruohonen and Sivill, 2011) takes into account the realistic possibilities how much heat can be recovered from the streams. The advanced composite curves present the upper and lower limits for the temperature levels where heat can be taken into the process, and therefore they can be used to define an upper and lower limit for the possibility of recovering heat from soft streams. This is achieved by combining the advanced composite curves with sophisticated humid air heat exchange simulation. The methodology is defined as follows:

1. Analysis of the plant using the advanced composite curves
2. Calculation of heat recovery possibilities in two cases:
  - a. The heat is taken to the streams that compose the Extreme Heat Load Curve
  - b. The heat is taken into the streams that compose the Theoretical Heat Load Curve
3. Presentation of the results in graphical way using two new curves

The current heat recovery of the mill is between the two extreme cases and can be shown in the AHLC. The heat recovery possibilities are calculated using a thermodynamic simulation program presented by Sivill et al. (2005). The program calculates heat transfer rate for any given heat recovery system that may include condensing streams and for which the state of the incoming streams (temperature, humidity and flow rate), structure and heat transfer surface area are known (validation in (Sivill et al., 2010)). The program is used to examine the impacts of retrofitting and changing the operation point of the studied heat exchanger network in cases 2a and 2b.

## 3. Simplified example

To highlight the approach presented earlier (Ruohonen and Sivill 2011), a simplified case with only two cold and two hot streams and one stream of exhaust air is presented. The stream data for the case is shown in Table 1.

Table 1: Stream data of the simplified case

Type of stream	Start temperature (°C)	Target temperature (°C)	Heat content (kW)	Description
Cold	30	70	8357	Water to process
Cold	10	25	12000	Raw water
Hot	80	60	12000	Hot filtrate
Hot	30	25	1000	Effluent
Soft	70	61 *	4850 *	Exhaust air

\* Original values that can be changed if found reasonable.

The case can be seen to represent a section of a typical paper mill, but most of the streams are left out of the analysis to achieve simplicity. For the same reason, round figures are used for heat and cooling demands outside the exhaust air flow itself. The original heat exchanger network is shown in Figure 2.

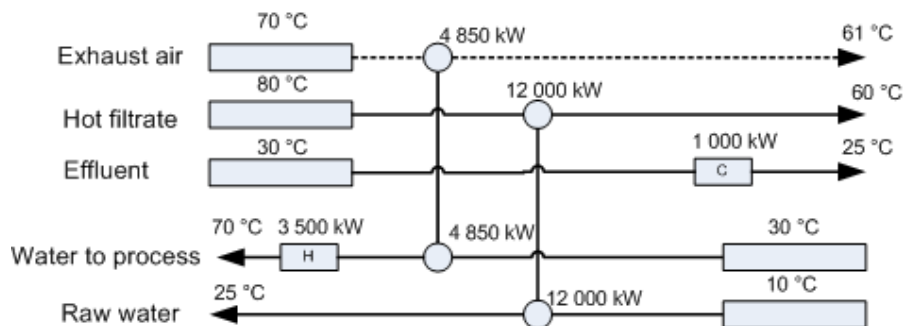

Figure 2: The original heat exchanger network

The exhaust air is used to heat the process water, the hot filtrate to heat the raw water and effluent is cooled before the treatment by river water. Currently, 3 500 kW is needed from the steam supply for the process water to reach the target temperature of 70 °C.

Advanced composite curves for the process are shown in Figure 3. A  $\Delta T_{\min}$  of 20 °C corresponds to the current utility consumption.

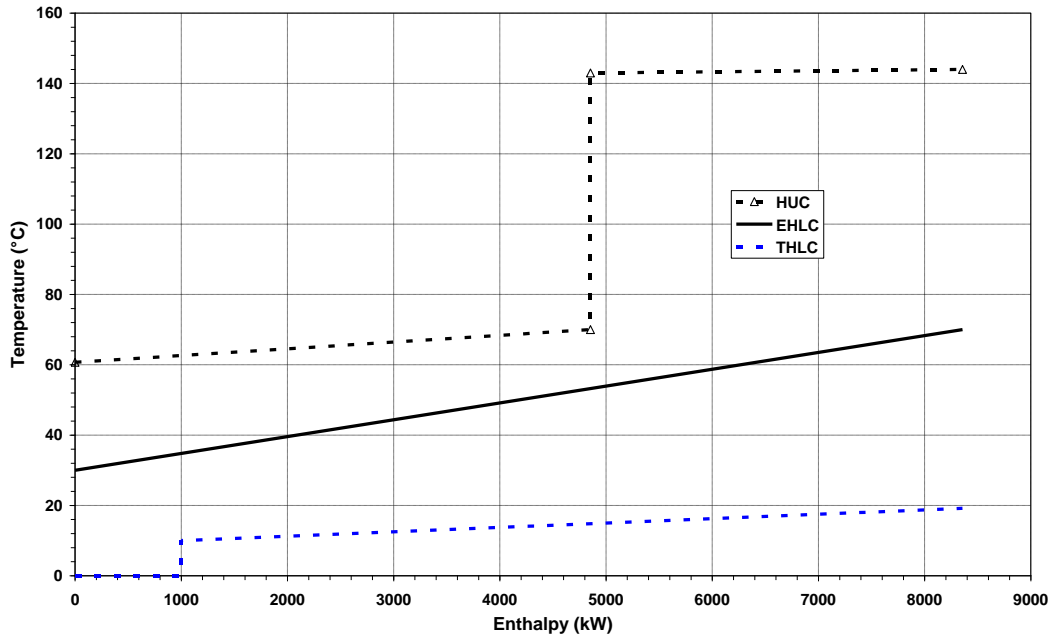

Figure 3: Advanced composite curves of the process

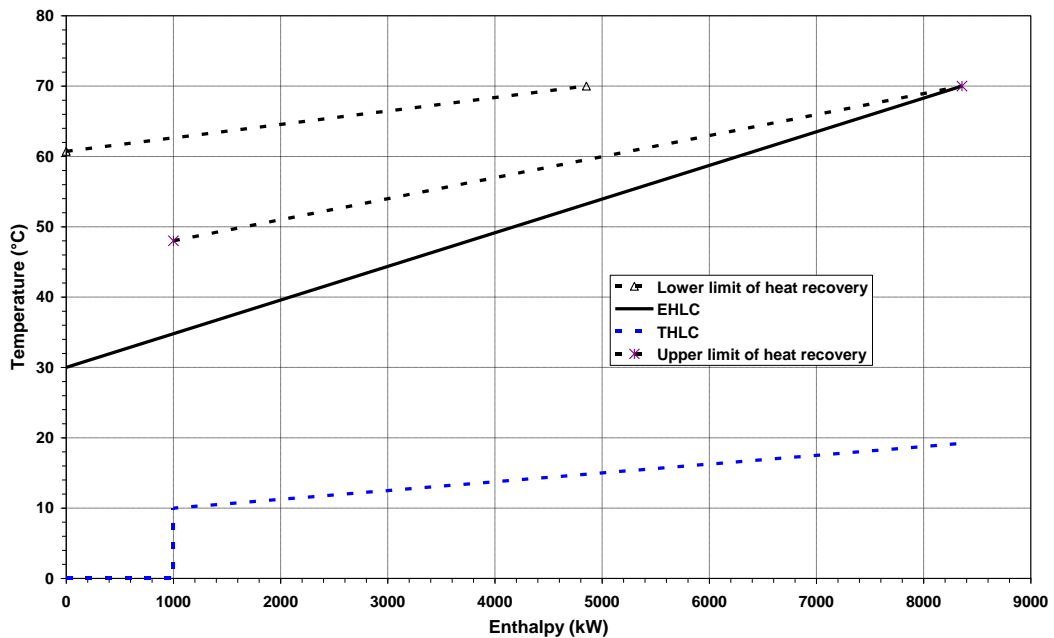

Figure 4: Upper and lower limits of heat recovery for the exhaust air

In this case, the AHLC overlaps with the EHLC and, therefore, it is not shown. The EHLC shows the highest temperature level on which heat can be taken to the process and the THLC shows the corresponding lowest temperature level. The two possibilities for heat recovery are shown in Figure 4. In this case, the lower limit corresponds to the original case and the upper limit can be reached if the array of the flows is changed so that the cold raw water flow is taken to the heat exchanger for the exhaust air instead of the process water. The process water will be heated by the hot filtrate instead of the exhaust air. The modified heat exchanger network is shown in Figure 5.

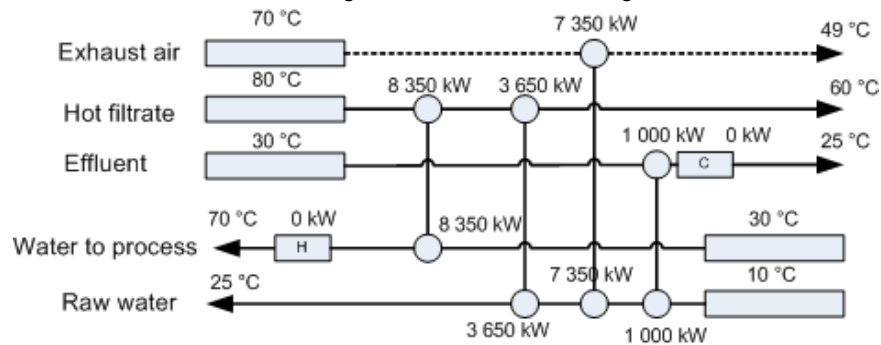

Figure 5: Modified heat exchanger network.

The Figure shows the theoretical solution obtained by pinch analysis. In reality, there is no idea to have an extra heat exchanger for the effluent, but more heat would have been taken from the exhaust air and the effluent would have been cooled as before.

#### 4. Conclusions

The method shown in this paper can be used to estimate the possibilities of heat recovery from moist air or similar streams with a two phase flow with a satisfactory precision. The use of simulation tools for the heat recovery give reliable values for the correct amount of heat that can be recovered.

In the case shown in this paper, all of the heat demands of the process can be covered by heat from the heat recovery, if the heat is taken into the stream with the lower temperature level instead of the original design.

It should be noted, that an approach where the larger amount of heat recovery would be locked in advance and treated as a hot stream, is not feasible when discussing multi phase flows and condensation. In this case, the amount of heat that is available is *dependent* of the network structure, and cannot be known beforehand.

The methodology presented in this paper gives a possibility to reliably estimate the possibilities of heat recovery also in larger problems, because the detailed simulations need to be performed only for two possibilities; the extreme heat load curve and the theoretical heat load curve. This assures that the extra effort needed for the estimation is only a small part of the overall pinch project. The traditional approach would require more work to achieve as reliable estimates, because all possibilities would have to be investigated one by one. The use of the advanced composite curves limits the detailed simulations to two runs.

Currently, the methodology uses modular heat exchanger packages in simulation to assure that the proposed solutions are possible to implement in an industrial case. The choice between the units is done manually, but in the future the selection of the packages could be automated to further simplify the use of the methodology.

#### References

- Linnhoff B., Townsend D.W., Boland D., Hewitt G.F., Thomas B.E.A., Guy A.R., Marsland R.H., 1994, A user guide on process integration for the efficient use of energy. The Institute of Chemical Engineers. ISBN 9780852953433, Rugby, UK.

- Nordman R., Berntsson T., 2009a, Use of advanced composite curves for assessing cost-effective HEN retrofit 1: Theory and concepts. *Applied Thermal Engineering*, 29(2-3), 275-281.
- Nordman R., Berntsson T., 2009b, Use of advanced composite curves for assessing cost-effective HEN retrofit 2: Case studies. *Applied Thermal Engineering*, 29(2-3), 282-289.
- Ruohonen P., Ahtila P., 2009, Analysis of a thermo mechanical pulp and paper mill using advanced composite curves, ECOS 2009 22<sup>nd</sup> International Conference on Efficiency, Cost, Optimization, Simulation and Environmental Impact of Energy Systems, Lecture 9.20, Foz do Iguassu, Brazil.
- Ruohonen P., Ahtila P., 2010, Analysis of a mechanical pulp and paper mill using advanced composite curves. *Applied Thermal Engineering*, 30(6-7), 649-657.
- Ruohonen P., Hakala J., Ahtila P., 2010, Analysis of an operating TMP mill using advanced composite curves and Heat Load Model for Pulp and Paper, PRES 2010, *Chemical Engineering Transactions*, 21, 541-546.
- Ruohonen P., Sivill L., 2011, A Novel Approach for Including Multi Phase Flows into Pinch Analysis – The Heat Exchange Limits Estimated by the Advanced Composite Curves, PRES 2011, *Chemical Engineering Transactions*, 25, 557-562
- Sivill L., Ahtila P., Taimisto M., 2005, Thermodynamic simulation of dryer section heat recovery in paper machines, *Applied Thermal Engineering*, 25(8-9), 1273-1292.
- Sivill L., Manninen J., Ahtila P., 2010, On-line energy efficiency monitoring for heat exchanger networks, *Computer Aided Chemical Engineering*, 28, 1757-1762.