

Modelling of the Electrolysers Cooling System for the Fluorine Production Operator Training Simulator

Olga V. Egorova*, Nina V. Liventsova, Sergei N. Liventsov, Alexandr I. Gozhimov

National Research Tomsk Polytechnic University, Lenin st. 2, 634050, Tomsk, Russian Federation
 nagaizeva@tpu.ru

Computer training is one of the most perspective training methods for chemical production operators. The key elements of any Operator Training Simulator (OTS) are models of technological processes and their control systems. Production of fluorine is electrochemical. The analysis of literature sources showed that the question of electrochemical production process simulation for computer training is not studied as well as in the processes of petroleum chemistry, petroleum refining and power industry. As electrochemical production is widely spread in different branches of industry, the problem solving of their simulation for computer training purposes is important today. The development results of a new mathematical model of the electrolysers cooling system for fluorine production operator training simulator are presented in the article. The suggested model consists of the modules of processes simulation, control system and abnormal situations initiate. It allows simulating the system operation in normal and some abnormal modes, excluding start up and shut down procedures. The mathematical description of the modules is based on well-known approaches and laws. However, the modules set up instruments for simulation of different operation modes of equipment simulated by them have some features of novelty. Such specific variables as "fault characteristics" present in the mathematical description of the modules of processes simulation and control system and which set up the module for simulation of the required operating mode, and the module of abnormal situations simulation setting the variables values relying on the probabilistic selection of the simulated mode refer to this novelty. The model working efficiency was initially tested by comparing the plant experimental data with the simulated experiment data and expert survey. The testing proved that simulation results meet the requirements to the model at the given development stage. Further it is planned to add the possibility to simulate the modes of start-up and shut down, electrolysers bypassing to the model, and its more complete verification.

1. Introduction

Technological processes of fluorine production are very hazardous for people and environment in views of the use of highly aggressive components (Groult et al., 2007). Also, significant energy consumption is needed in case of incorrect control or unscheduled shut down of the production because of operators' mistakes. In such conditions professional training level of the operators managing technological processes is of great importance. A computer simulator (CS) can be a very effective for the training purposes (Patle et al., 2014). The key element of the CS according to (Patle et al., 2014) is the model of engineering system intended for simulation of the processes occurring in processing plants, and the system of controlling them in normal and abnormal situations. Creation of such model is considered to be the primary task at the computer simulator development.

Fluorine production is an electrochemical production process. The analysis of literature sources showed that the question of electrochemical production process simulation for computer training is not studied as well as in the processes of petroleum chemistry, petroleum refining and power industry (Patle et al., 2014). Since electrochemical production is widely spread in different branches of industry, the problem solving of their simulation for computer training purposes is important today. To date the models of the processes occurring in fluorine-containing electrolysers, which allow getting energy potential distribution, concentration of components and temperature in the electrolyte volume, taking into account the hydrodynamics of two-phase flows, have been developed for fluorine production (Pretorius et al., 2015). The primary task of these models is to study engineering solutions for changing the construction and process management modes to increase electrolysers

efficiency. No other subsystems present in process flowsheets of this production have been found. The development results of a new mathematical model of the fluorine production electrolyzers cooling system for the training simulator are presented in the article.

2. The electrolyzers cooling system

The cooling systems (CS) considered in the work operates in the following way: cooling water is supplied from a water treatment section to a pipe header. Then water flows along parallelly branched lines of the pipeline to each electrolyser of the series through control valves which operate according to control algorithms based on the electrolyte temperature measuring channels data. After that water flows along electrolyzers exchanger tube-sheets removing heat released during electrolysis and flows back into the storage water tank via general unloading manifold. The operated variables of the system are electric current of the series, electrolyzers voltage, electrolyte temperature and rate of control valves opening. Cooling water flow and temperature are measured by the water supply position in the pipe header after the pump and are not observed by the operator. The main control task is electrolyte temperature maintenance in electrolyzers at the required level by changing the cooling water flow by control valves at the heat-exchanger inlet of each electrolyser. The main disturbing units influencing the electrolyte temperature are the series current and cooling water temperature at the electrolyzers heat-exchanger inlet.

3. The electrolyzers cooling system model

3.1 Requirements to the model

In accordance with the tasks of computer training the CS model should: describe the whole system operation; take into account existing connections between equipment units comprising the loop, and reflect interconnections between technological variables, which characterize the loop operation, and allow the trainee to evaluate the operating mode and the instructor – to develop training scenarios; provide adequate process simulation while disturbing and control inputs necessary for training are sent in the range of their values change, which correspond to operational and abnormal modes; simulate abnormal conditions described in Table 1; operate in real-time and fast-time scales.

Table 1: List of abnormal situations

Situation code	Situation	Reason code	Reason
1	Electrolyte temperature growth	1.1	Control valve in the cooling water supply line is closed
		1.2	Motor valve in the cooling water pipeline is closed
		1.3	Uncoupling with the controller
		1.4	Cooling water pressure is lower than normal
		1.5	Partial impenetrability of the heat-exchanger
2	Electrolyte temperature drop	2.1	Uncoupling with the controller
		2.2	Control valve in the cooling water supply line is opened or passes through
		2.3	Cooling water pressure is higher than normal
3	Electrolyte temperature drop to the low value of the scale	2.4	Defect of the electrolyte temperature measuring channel
		3.1	Defect of the electrolyte temperature measuring channel

3.2 Model structure

On the basis of analysis of the functioning principle of the CS, requirements to the model for computer training purposes the model structure of the CS presented in Figure 1 was developed. It consists of the modules of processes simulation (MPS), the module of control system simulation (MCSS) and the module of abnormal situations initiate (MASI). The module of process simulations (MPS) includes the models of cooling water supply subsystem (CWSS) and electrolyzers, the module of control system simulation (MCSS) – the models of measuring subsystem and electrolyte temperature control blocks. The model of CWSS includes the pump model taking into account pressure change at the inlet of the pipe header of the CS pipeline (P_{WH}) at the load change, and the water flow distribution model in the pipework, taking into account the pipeline configuration and control valves operation.

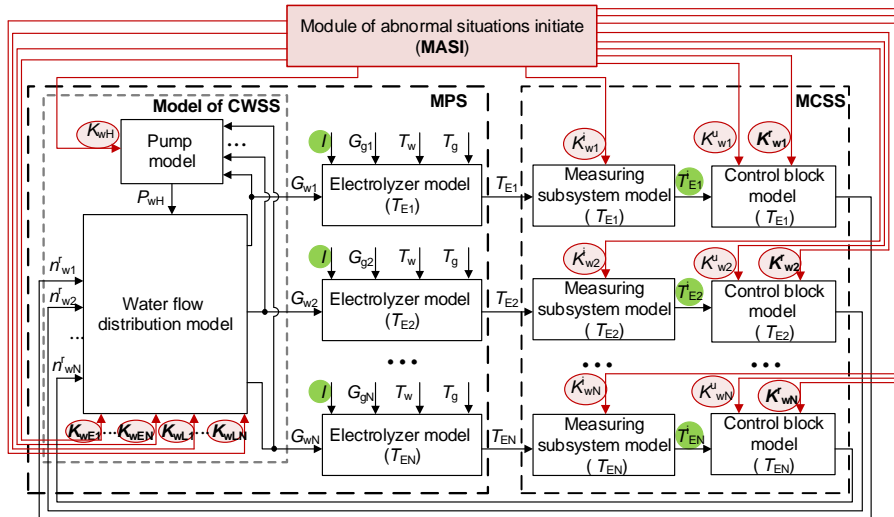

Figure 1: Structure of the electrolyzers cooling system model

The electrolyzers models are intended for calculating electrolyte temperatures (T_E) depending on series current change (I), flow (G_w) and cooling water temperature (T_w), flow (G_g) and temperature (T_g) of hydrogen fluoride (HF) supplied into equipment units. Measuring subsystem models are used for converting calculated electrolyte temperature values into the form of (T_E), represented on the operator panel screen. The models of control blocks describe operation of local automated control systems of electrolyte temperature according to the used control algorithms. Their main task is to maintain electrolyte temperature at the required level by changing the control valves opening rate (n_w). All models of the system have specific variables called “fault characteristics” (K), included into the model description in order to simulate the normal mode and abnormal situations presented in Table 1 in case of their values change.

3.2.1. Model of CWSS

CWSS comprises several similar parallel pipelines, valves and exchanger tube-sheets of electrolyzers connected with the general flow source. The pipelines with control valves and exchanger tube-sheets are called electrolyzers cooling lines. The simplified scheme of the subsystem is presented in Figure 2.

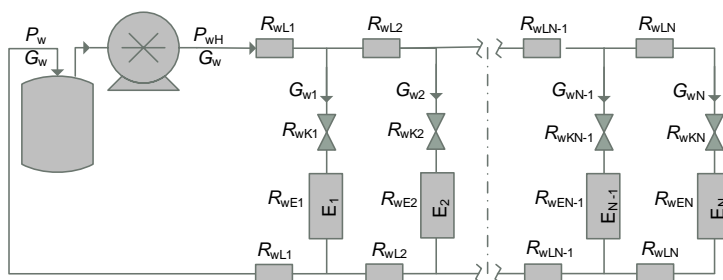

Figure 2: Simplified scheme of CWSS

The following designations are used in Figure 2: P_w , P_{wH} – static pressure in water conditioning tank and flow source pressure, Pa; G_w , $G_{w1, \dots, N}$ – mass water flow at the inlet of pipeline of CWSS and electrolyzers heat exchangers, kg/s; $R_{wL1, \dots, LN}$, $R_{wK1, \dots, N}$, $R_{wE1, \dots, N}$ – flow resistance of the general pipelines between electrolyzers, valves and electrolyzers exchanger tube-sheets, 1/kg·m; N – number of electrolyzers.

The pump model calculates pressure change (P_{wH}) at the inlet of the pipe header of CWSS by the relation:

$$P_{wH}(t) = K_{wH} \cdot f(t), \quad (1)$$

where $f(t)$ – corresponds to the linear section of the pipeline load characteristic of CWSS, which responsible for operating mode (its maintenance at the plant is provided by variable-frequency control of rotary pumps used for creating the flow). This section of the load characteristic is approximated by the following dependence:

$$f(t) = (813,212 \cdot G_w(t) + 76,170). \quad (2)$$

The total flow in the cooling system according to the simplified scheme (Figure 1) is:

$$G_w(t) = \sum_{z=1}^N G_{wz}(t). \quad (3)$$

To provide the simulation possibility of the general flow drop in the pipeline which is connected with the flow source defect the "fault characteristic" K_{wH} , which varies in the range of (0, 1] (1 – corresponds to normal mode, all other- to abnormal mode), was added to the relation (1).

The model of the water flow distribution calculates the values of cooling water mass flow in electrolyzers cooling lines. The use of this model in CS requires: dynamic calculation of the flow in points of the pipeline, consideration of the pipeline topology, guarantee convergence at any versions of control valves condition. Therefore, to develop the model the method based on the loop flow method and the equation of medium motion impulse change (Thomas,1999).

Accordingly, the pipeline is divided into independent loops the number of which is equal to the number of possible independent combinations of pipeline branches, the beginning and the end of which have constant values of static pressures. For the network of CWSS the number of such loops is equal to the number of electrolyzers cooling lines. An expression of the medium impulse change is written for each loop. The solution result of the system of equations are values of flow changes in each loop which in case of the simulated pipeline are equal to true values of mass flows of electrolyzers cooling lines.

In order to simplify the procedure of calculation the following assumptions are made: the medium occupies the whole cross section of the pipeline; cooling water temperature changes insignificantly while moving along the pipe header; the directions of process flows do not change; geometry of the pipelines in space is constant; pressure drop at hydraulic resistance is proportional to the square of the medium mass flow; cross section of all pipelines is equal; there is no level difference between the source and water drain; the same water level ($P_w = \text{const}$) in the water treatment tank is maintained.

In accordance with the method the pipeline network of CWSS is divided into N of independent loops, which start and end at the water treatment tank, including the flow source and the corresponding electrolyser cooling system. Equations of medium impulse change for each loop are given below:

$$\frac{dG_{wz}(t)}{dt} = \begin{cases} \frac{S_w}{l_{wz}} \cdot \left[P_{wH} - \left(2 \cdot \frac{R_{wLz}}{K_{wLz}} + R_{wz}(t) \right) \cdot G_{wz}^2(t) - 2 \cdot \frac{R_{wLz}}{K_{wLz}} \cdot \left(\sum_{i=z+1}^N G_{wi}(t) \right)^2 \right], & z = 1, \\ \frac{S_w}{l_{wz}} \cdot \left[P_{wH} - \left(2 \cdot \frac{R_{wLz}}{K_{wLz}} + R_{wz}(t) \right) \cdot G_{wz}^2(t) - \right. \\ \left. - 2 \cdot \frac{R_{wLz}}{K_{wLz}} \cdot \left(\sum_{i=z+1}^N G_{wi}(t) \right)^2 - 2 \cdot \sum_{j=z-1}^1 \left(\frac{R_{wLj}}{K_{wLj}} \cdot \left(\sum_{i=j}^N G_{wi}(t) \right)^2 \right) \right], & z > 1, \end{cases} \quad (4)$$

where $z = 1, \dots, N$; S_w – the cross section area, m^2 and l_{wz} – section length, m of the z-th line of the pipeline; $R_{wz} = R_{wEz} / K_{wEz} + R_{wKz}$.

Hydraulic resistances R_{wLz} and R_{wEz} depend on the length, diameter and quantity of bends of supply pipelines and exchanger tube-sheet. They were calculated by Idel'chik (2008). Hydraulic resistances R_{wKz} depend on position of the control valves and are calculated by the relation resulting from load and flow characteristics:

$$R_{wKz}(t) = \frac{12,362}{K_{V_w} \cdot \left(G_{w100} \cdot \frac{n_{wz}^r(t)}{100} + G_{wK0} \right)^2}, \quad (5)$$

where K_{V_w} – correction factor for adjusting the valve load characteristic; G_{wK0} – water leakage when the valve is closed, kg/s; G_{w100} – flow when the calve is completely open, kg/s.

In order to provide the simulation possibility of abnormal operation of the pipeline elements the ratios for calculating hydraulic resistances of the pipeline elements in (3) are added with the "fault characteristics" K_{wLz} , K_{wEz} (partial impenetrability of the pipeline is simulated by K_{wLz} , and of the heat exchanger – by K_{wEz}). The characteristics change in the range of (0, 1] (1 corresponds to normal mode, all other –to abnormal modes).

3.2.2. Electrolyser model

Electrolysers models have similar structure and differ by the values of parameters considering peculiarities of operation and obtained by them during operation process. In the description of the heat exchanging process the electrolyser is presented by the system receiving heat from electric current and supplied HF and giving up heat via exchanger tube-sheets, external case walls and with removed gases. The value of heat consumption from electrolyte evaporation and other factors is insignificant and is not considered. Mathematical description of the model was presented in the work Liventsova (2012).

3.2.3. Measuring subsystem model

The models of subsystems of the measurement convert calculated values of electrolyte temperatures into the form in which they are observed by the operator on the control panel screen. Also, they provide simulation of abnormal situations connected with defects of measuring channels elements. Since all measuring channels are the same, the subsystems models are described similarly:

$$X_{Ez}^i(t) = T_z^{low} + K_z^i \cdot (T_{Ez}(t) \cdot \alpha_z - \beta_z - T_z^{low}), \quad (6)$$

where T_z^{low} – the low bound of the sensing scale; α_z, β_z – scaling and displacement coefficients; K_z^i – “fault characteristics” for simulating equipment unit shutdown or breaking of the signal line ($K_z^i = 0$ – in case of the fault; $K_z^i = 1$ – in case when no faults occur). In this condition restrictions $T_z^{low} \leq T_{Ez}(t) \leq T_z^{up}$ are applied to the value of $T_{Ez}(t)$, where T_z^{up} – is the upper bound of the sensor scale.

The dynamics of the measurement is described by the following equation:

$$T_z^d \frac{dT_{Ez}^i(t)}{dt} + T_{Ez}^i(t) = X_{Ez}^i(t), \quad T_z^d - \text{time response of sensor, s.} \quad (7)$$

3.2.4. Control block model

The control block model consists of the control algorithms models (CAM) and control valve (CVM). The models of all control blocks have the same description. CAM simulates operation of the relay-type electrolyte temperature control algorithm with the possibility to switch to digital (by Pi-law with disturbance compensation) and switch to manual control mode. The model calculates the opening rate values ($n_{wz}^u(t)$) of the control valve of cooling water flow according to selected control algorithm by the values of T_{Ez} to maintain the electrolyte temperature at the required level. The “fault characteristic” K_{wz}^u , which gets the value of 1 in the normal mode and 0 - in case of the fault, is included into the ratios describing CAM for simulation of uncoupling with the controller by the control channel. CVM calculates real positions of control valves ($n_{wz}^r(t)$) of cooling water supply. As the pneumatic mechanism is used as executive and its response time is insignificant, it can be neglected in simulation of the control valve position change. The valve position $n_{wz}^r(t)$ is determined by $n_{wz}^u(t)$ from CAM taking into account possible “fault characteristics” $K_{wz}^{r0}, K_{wz}^r, K_{wz}^{rk}$. in accordance with the following ratio:

$$n_{wz}^r(t) = K_{wz}^{rk} \cdot K_{wz}^r \cdot n_{wz}^u(t) + 100 \cdot K_{wz}^{r0}. \quad (8)$$

Simulated abnormal situations: valve failure in “Open”, $K_{wz}^{r0}=1, K_{wz}^r=0, K_{wz}^{rk}=1$; valve failure in “Closed”, $K_{wz}^{r0}=0, K_{wz}^r=0, K_{wz}^{rk}=1$; $K_{wz}^{r0}=0, K_{wz}^r=0, K_{wz}^{rk}=1$; valve failure in current position (valve “sticking”): $K_{wz}^{r0}=-1, K_{wz}^r=0, K_{wz}^{rk}=1$ (при $K_{wz}^{r0}=-1, n_{wz}^r(t) = n_{wz}^u(t-1)$); normal operation: $K_{wz}^{r0}=0, K_{wz}^r=1, K_{wz}^{rk}=1$. In this case the restriction $0 \leq n_{wz}^r(t) \leq 100$ is applied to the value $n_{wz}^r(t)$.

3.2.5. Module of abnormal situations initiate

The module operation is based on the mechanism providing the probabilistic selection of the simulated condition and time of its duration. Each condition and reasons causing it are given unique numbers. Each combination of the condition number with the reasons number is associated with the combination of the “fault characteristics” values required for simulation of one or another condition. At the time moment t the probabilistic forming of the combination of the condition number with the reason number occurs. Accordingly, the required combination of the “fault characteristics” with necessary values is chosen.

4. Results of numerical experiments

Initial evaluation of the model efficiency was carried out by the experts by visual comparison of the graphs of simulated electrolyte temperature changes with the plant data. The experts considered the results satisfactory at this stage of the model development. In Figure 3 some of the results are presented. All calculations were made in MATLAB using built-in functions and differential equations solvers of the environment kernel (Moore,

2015). Figure 3a shows the simulated electrolyte temperature changes of the 15th and 30th electrolyzers of the system (T_{E15} , T_{E30}) at the series current change (I) and the control valves opening rate (n_{w15}^f , n_{w30}^f) in normal operation mode in comparison with the plant data. Figure 3b presents the result of abnormal situation simulation 1.2 (see Table 1) (from 0 to 500 s) taking into account available plant measurements.

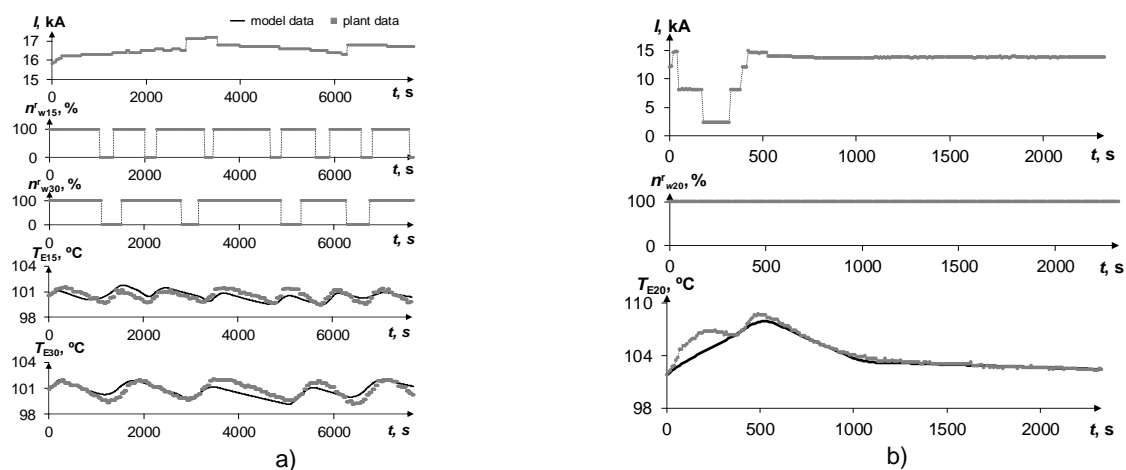

Figure 3: Results of numerical experiments

Further it is planned to add the possibility to simulate the modes of start-up and shut down, electrolyzers bypassing to the model, and to perform numerical evaluation of its adequacy at simulation of normal and stated abnormal mode.

5. Conclusions

The new mathematical model of the electrolyzers cooling system for fluorine production OTS consisting of the modules of processes simulation, control system simulation and abnormal situations initiate was developed. The first module calculates redistribution of cooling water mass flow in the pipeline net and electrolyzers electrolyte temperatures. The second module simulates operation of subsystems of measurement and automated control algorithms of electrolyzers electrolyte temperatures. The third module sets the model for simulation of normal and abnormal operation modes of the cooling system. Mathematical simulation of the modules is based on conventional approaches and laws. However, the presence of some instruments for simulation of different operation modes of equipment brings some features of novelty. Initial expert evaluation of the model efficiency by visual comparison of the graphs of simulated electrolyte temperature changes with the plant graphs proved to be satisfactory. It is further planned to complete the model with the possibility to simulate start-up and shut down procedures modes and electrolyzers bypassing, and to perform numerical evaluation of the model adequacy at simulation of normal and stated abnormal situations.

References

- Groult H., Lantelme F., Salanne M., Simon C., Belhomme C., Morel B., Nicolas F., 2007, Role of elemental fluorine in nuclear field, *J. Fluorine Chem.*, 128, 285–295.
- Idelchik I.E., 2007, *Handbook of Hydraulic Resistance*, 4th Revised ed., Begell House Inc., Redding, USA.
- Liventsova N.V., Egorova O.V., Liventsov S.N., Denisevich A.A., Belanin A.V., Sherengina A.A., 2012, Simulation module processes of electrolytic thermal circuit for a fluorine production operator of computer simulator, *Industrial Automatic Control Systems and Controllers*, 9, 35–42 (in Russian).
- Moore H., 2015, *MATLAB for Engineers*, Pearson Education Inc, Salt Lake City, USA.
- Patle, D.S.; Ahmad, Z.; Rangaiah, G.P., 2014, Operator training simulators in the chemical industry: Review, issues, and future directions, *Rev. Chem. Engineering*, 30, 199–216.
- Pretorius R., Crouse Philippus L., Hattingh C. J., 2015, A multiphysics simulation of a fluorine electrolysis cell, *S. Afr. J. Sci.*, 111, 7-8.
- Philip J.T., 1999, *Simulation of Industrial Processes for Control Engineers* (Chapter 19), Butterworth-Heinemann, Oxford, United Kingdom.