

# The Integrated Health Monitoring Design Using the Dynamic Flowgraph Methodology for Thermal Control Systems of Payloads

Jianming Shi\*, Gong Wang, Ying Liu Tiefeng Tong

<sup>a</sup>Technology and Engineering Center for Space Utilization, Chinese Academy of Sciences, NO.9 of South Dengzhuang Road, Haidian District, Beijing, China.  
[sjm@csu.ac.cn](mailto:sjm@csu.ac.cn)

The thermal control system (TCS) is an important constitution of payload racks. It takes away the waste heat generated by science experiments to maintain the temperature within the accepted range. TCSs consist of components like valves, fluid pipe lines, cold plates, pumps, controllers, and interfaces with Internal Active Thermal Control System (IATCS) of the space station. The payload temperature control is executed by automatic valve positioning and pump driving for flow via predefined command or crew laptop or ground workstation in real-time. The performance of a TCS, to a great extent, correlates to the health status of these components and the interactions between them. If one component falls in an abnormal condition, the TCS may fail to manage the payload thermal environment, causing a science experiment failure or even a safety incident. Therefore, it is significant to integrate the health monitoring capability into the TCS during the design process. Nevertheless, the failure mechanism of a TCS is complex due to that there exist dynamic interactions between system components, especially hardware (HW) and software (SW) interactions. It is reported insufficient to model such dynamic interactions using conventional reliability tools. Dynamic flowgraph methodology (DFM) is an advanced reliability modeling method, which can precisely describe the multi-valued component status and the dynamic interactions. TCS designer can get more accuracy of system failure modeling by using DFM. It can aid to the IHM design process in selecting test points, generating diagnosis strategy, events reporting etc. This paper firstly illustrates the TCS of payloads, which is followed by a brief introduction of the DFM technique. And then the TCS is modeled and analyzed, thus the DFM model and analytical results are applied in the integrated health monitoring (IHM) system design for TCS.

## 1. Introduction

The space station, as a long period habitation for human beings, provides extraordinary different conditions compared with ground laboratories for scientific research and experiments. There exist two independent loops in the laboratory module of the space station, which are low temperature loop (LTL) and moderate temperature loop (MTL) respectively. MTL nominally operates at 17 °C and provides most of the cooling for system equipment and payload experiments.

The rack is the supporting platform for payload experiments, providing the capabilities of power management, thermal control, and data processing and so forth. The thermal control system (TCS) of the payload rack draws the cooling water into the rack through the interface with MTL, and distributes the water by the pipelines, cold plates and heat exchangers so as to take away the waste heat produced by the rack electronics and payload experiments. The TCS mainly consists of pipelines, valves, cooling water, heat exchangers, fans, sensors and controllers. The start/shut, loop reconfiguration, valve controlling and temperature monitoring of the TCS are executed by controllers. The information about the TCS (e.g. temperature, flow, pressure) is displayed in the rack indicators, or transferred to laptops as needed.

The TCS malfunction can disturb the scientific experiment directly, or even impose hazards on the space station and the crew. Therefore, the performance of the TCS must be monitored in real time. It is

significant to integrate fault diagnosis and health monitoring capability in the TCS design, involving sensors, data acquisition card, on-line emergency processor, failure alarming device and health information downward transmitter. In flight emergency needs to be handled immediately, as an example of the cooling water leakage and abnormal high temperature. As soon as one abnormal condition is detected, the causes and effects of it must be revealed at once, so that we can take precautionary or protective measures against the emergency.

As the failure modes of the TCS are so complicated that we need a method to detail the dynamic behaviour of the system. Petri-Net, Go-flow, Bayes Net, Dynamic Flowgraph Methodology (DFM) are these kinds of methods for solving the problems. The TCS of payload rack is similar to the digital feed water control system of nuclear power plant, and DFM has been approved to be successful in the failure modelling and probability risk analysis (PRA) of the digital systems, so the paper utilized DFM to build the failure model of the TCS. The DFM model and its analysis results were then applied for designing the integrated health monitoring module, which integrates the fault diagnosis capability into the TCS of racks.

## 2. The TCS scheme of payload racks

The basic scheme of the TCS is illustrated in Figure 1. The system is combined with two sections namely air loop and water loop. As shown in Figure 1, thick lines represent air loop, and thin lines represent water loop. The red colour means the fluids at higher temperature, as the blue means the fluids at lower temperature. The water loop consists of air-liquid heat exchanger, Teflon corrugated pipes, cold plates, valves, and sensors. The air loop consists of fan, air-liquid heat exchanger, air pipes, strainers, flow regulator, temperature sensors and smoke detector.

The cooling water from MTL is divided into 3 branches of flows: the first two branches are provided for the Standard Payload Units (SPUs) 1~4 and SPUs 5~8 of the standard rack; the last one goes into the air-liquid heat exchanger, absorbs the heat of air loop, and goes on flowing to the cold plate of the Standard Drawer Unit (SDU) for rack electronics. The water flows are controlled by valves through the commands from actuator controlling systems.

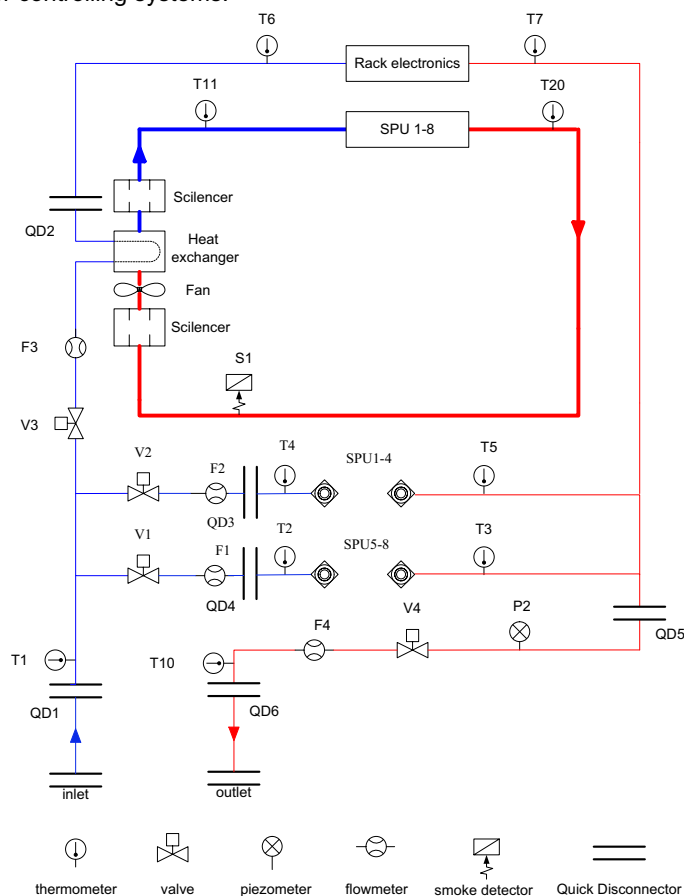

Figure 1: The basic TCS scheme of the rack

### 3. DFM modelling of the TCS

#### 3.1 The DFM model of the TCS

Figure 2 shows the DFM model of the TCS. The model contains process variables, actuators, the interactions between the software (SW) and hardware (HW), and the dynamic interactions between the TCS and the controlled process. The process variables are temperatures and flow fluxes. The actuators are electromagnetic valves. The thermal control software interacts with the valve hardware to drive the actuator. The DFM model in this paper does not contain quick connectors, silencers, smoke detectors and air loops as depicted in Figure 1. The condition nodes of actuator controlling systems and remote operations in the model were not developed and their failures were not considered in this paper.

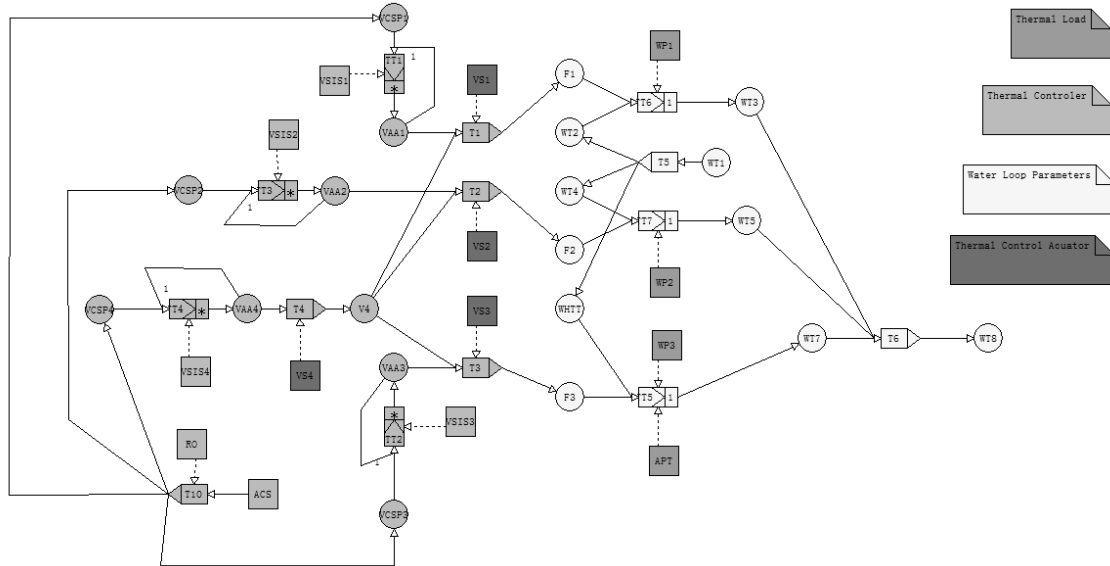

Figure 2: The DFM model of the TCS

Table 1: Node definitions for the TCS DFM model

Node	Description	State discretization
WT1	Temperature of the inlet water of the rack	normal high
WT2	Temperature of the inlet water of SPUs 5-8	normal high
WT3	Temperature of the outlet water of SPUs 5-8	normal high
WT4	Temperature of the inlet water of SPUs 1-4	normal high
WT5	Temperature of the outlet water of SPUs 1-4	normal high
WT7	Temperature of the outlet water of rack electronics	normal high
WT8	Temperature of the outlet water of the rack	normal high
WHHT	Temperature of the inlet water of the heat exchanger	normal high
F1	Water flow at the inlet of the cold plate of SPUs 5-8	zero normal
F2	Water flow at the inlet of the cold plate of SPUs 5-8	zero normal
F3	Water flow at the inlet of the heat exchanger	zero normal
V4	Open/Closed state of the valve at the outlet of the rack	closed open
VCSP1-4	Controlling software parameters for valves 1-4	close open
VAA1-4	Actions of valves 1-4	close open
WP1	Thermal load of water cooling for SPUs 5-8	none normal high
WP2	Thermal load of water cooling for SPUs 1-4	none normal high
WP3	Thermal load of water cooling for rack electronics	none normal high
APT	Total thermal load of air cooling	none normal high
VSIS1-4	Valves 1-4 SW interface status	normal sopen sclose frozen
VS1-4	Hardware functional status of valves 1-4	normal fopen fclosed
ACS	Actuator controlling systems	normal
RO	Remote operations	normal

The explanation for each node in the DFM model is listed in Table 1. The nodes are each discretized into a finite number of states. For continuous variables, the discretization corresponds to a discrete representation of the possible range that the variable can take. On the other hand, for component states, the discretization reflects the failure modes and normal state.

Decision tables contained in “transfer boxes” and “transition boxes” describe the cause-effect and time-effect relationship of process variables in DFM. Here selected some of the “transfer boxes” and “transition boxes” in the DFM model to detail their decision tables.

Transition box “TT4” represents that valve 4 current action depends on current state of valve 4 controlling software parameter, current state of valve 4 software interface, and valve 4 action at the preceding time-step. The decision table summarizing the transition function is shown in Table 2.

Table 2: Decision table for the transition box TT4

VCSP4 (t = 0)	VSIS (t = 0)	VAA4 (t = -1)	VAA4 (t = 0)
VCSC	VSINorm	-	VCA
VOSC	VSINorm	-	VOA
-	VSIOpen	-	VOA
-	VSIClose	-	VCA
-	VSIFrzn	VCA	VCA
-	VSIFrzn	VOA	VOA

Transfer box “T1” represents that the water flow at the inlet of the cold plate of SPUs 5-8 depends on valve 4 state (open or closed), valve 1 action and valve 1 hardware functional state. The decision table summarizing the transfer function is shown in Table 3.

Table 3: Decision table for the transfer box T1

VAA1 (t = 0)	V4 (t = 0)	VS1 (t = -1)	F1 (t = 0)
VCA	-	VNorm	0
-	VClsd	-	0
-	-	VFClosd	0
VOA	VOpen	VNorm	1
-	VOpen	VFOpen	1

Transition box “TT6” represents that current temperature of the outlet water of the cold plate of SPUs 5-8 depends on the states of WT2, F1 and WP1 at the preceding time step. The decision table summarizing the transition function is shown in Table 4.

Table 4: Decision table for the transition box TT6

WT2 (t = -1)	F1 (t = 0)	WP1 (t = -1)	WT3 (t = 0)
-	-	0	0
0	0	1	1
0	1	1	0
1	-	1	1
-	-	2	1

## 4. The TCS IHM module design based on the DFM model

### 4.1 Selection variables related with health status

DFM has the advantage to integrate the controlled processes into system reliability model, which can serve as a means to select monitored variables measuring the system health status. As shown in Figure 3, “thermal load” and “water loop parameters” can be applied for choosing variables. Thermal load, as condition nodes, is determined by the power of electric equipment. Therefore, thermal load can be monitored by continuously measuring the current and voltage of the electric equipment. Water loop parameters are mainly the values of flow and temperature at some point, which can be sensed by flow meters and temperature sensors. The sensors in the TCS scheme are designed for thermal control mechanism, though they can be selected for IHM scheme according to the DFM model. Besides the sensors in the TCS scheme, we need to design self-diagnosis circuits into the ACS to monitor the state of valve SW interface.

#### 4.2 Fault detection and diagnosis on orbit

As the sensors can fail to output normal signals, so that the variables are not 100% credible. The decision tables give the coupling relations of the nodes, which can be used for information fusing to reject abnormal signals so as to reduce false alarms.

During the scientific experiment mission time, the TCS is in charge of cooling payload equipment and rack electronics. If the TCS has a fault or thermal load is out of nominal range, the temperature of the rack outlet water (WT8) may exceed the permitted value. The experiment must be interrupted. The top event of interest is expressed like this: at initialization of the experiment the system was normal without any fault, the valve controlling software parameters were all “open” and the inlet water temperature of the rack was normal as well; however, after a period of system operating, some fault may happen in the system, and then causing WT8 exceeding the limit a time step after the fault appearance. Table 5 summarizes this top event.

Table 5: The top event of “WT8 exceeded limit”

DFM node state	Time stamp	Meaning
WT8=1	0	WT8 reaches an abnormal high state
ACS=0	-1	ACS was normal
APT=0	-1	Air coolant thermal load was nominal
RO=0	-1	RO was normal
VCSP1=VOSC	-1	VCSP1 was “open”
VCSP2=VOSC	-1	VCSP2 was “open”
VCSP3=VOSC	-1	VCSP3 was “open”
VCSP4=VOSC	-1	VCSP4 was “open”
WT1=0	-1	WT1 was at normal state
WT2=0	-1	WT2 was at normal state
WT3=0	-1	WT3 was at normal state
WT4=0	-1	WT4 was at normal state

Using the DFM software tool to carry out the qualitative deductive analysis, the TCS model is tracked backwards in time and causality to get the prime implicants for the top event. Each of the prime implicants is a combination of basic event with time stamp, very similar to minimum cut sets in fault tree analysis. In the analysis, time step  $t=-1$  refers to a time after the initial of a scientific experimental mission, and time step  $t=0$  means the steady time for WT8 after the change of system state at  $t=-1$  as a result of heat conduction time lag. The deductive analysis yields 21 prime implicants for the top event, 4 of which are listed in table 6.

Table 6: The prime implicants of “WT8 exceeded limit”

NO.	Prime implicant	remarks
1	VAA2=VCA@t=-2 VS2=VNorm@t=-1 VSIS2=VSIFrzn@t=-1 WP2=1@t=-1	Valve 2 actuator action was “close” at the time step $t=-2$ , but this is generally not the real situation because the valve is open as soon as the experiment starts.
2	VS1=VFClosd@t=-1 WP1=1@t=-1	Valve 1 failed closed, so the value of F1 is zero, making WT3 and WT8 abnormal
3	VS1=Norm@t=-1 VSIS1=VSIClose@t=-1 WP1=1@t=-1	Valve 1 software interface stuck at close, and the result is the same as NO.2 implicant
4	WP1=2@t=-1	WP1 is too high.

Referring to the prime implicants deduced by the DFM analysis engine, fault diagnosis can be executed for the top event. The diagnosis process is to compare the prime implicants with the measured values of the nodes, and finally the causes for the abnormal condition can be obtained. Moreover, the basic failure event of one component can be forward-propagation tracking to get a series of time-dependent event sequences, which is also known as inductive analysis. For instance, if the valve software interfacial state is stuck at close according to the self-diagnosis circuits of ACS, the effects of this failure can be gained by the inductive analysis. After the diagnosis of failure reasons and effects, the related information is displayed for the crew, and decisions is made to recovery the rack so as to guarantee the system safety and mission success.

## 5. Results and Discussions

### 5.1 Results

The dynamic interfaces within the TCS are solved by DFM. The model built in this paper is aimed for IHM design. The conclusions of the research in this paper are summarized as follow.

1. The DFM model can be used for the selection of variables of health information.

The TCS DFM model integrates the TCS itself and the process under controlling, and the interactions between them are considered. The process variable nodes in the DFM model can be served as the reference for designing data acquisition systems of IHM. The list of complete variables selected for sensing can be retrieved from the accurate DFM model. The coupling relationship of these variables along with proper redundancy can also be provided, making the detection of abnormal conditions more reliable.

2. The DFM analysis can be applied for fault diagnosis.

The DFM model describes the logical process of system behaviour through the cause-effect and time-dependent relations of multi-valued nodes that are divided into finite number of discrete states. The DFM model can be analysed in two ways: deductive analysis and inductive analysis. The information collected by data acquisition systems corresponds to the process variable nodes in the DFM model. If abnormal condition is detected and confirmed, the causes and effects can be quickly and precisely defined.

### 5.2 Discussions

As shown in Figure 3, the TCS model involves two types of time lags: 1) the heat conduction time lag; 2) the time lag between two adjacent actions of the valve actuator. The first time lag is a deterministic value, while the second one is undefined because the valve actuator operational strategy is not sure.

The TCS is manipulated through remote operations or crew laptops. Before the experiment starts, the TCS must be checked to make sure it works normally. When the rack is working, the valve controlling software parameters are all "open". The valves should be open all the time during the mission. However, some faults may happen and the valve may shut. "VISIClose" and "VFClosed" are the faults that can make the valve closing. These two failure modes happen stochastically, but if one of them comes true WT8 will exceed the limit in a time step. Although the transition boxes in the model have the same time lags (1 time step), it is not always the scenarios as the second type of time lag relates to the sampling frequency of thermal controlling and the valve commanding strategy. If the valve needs to react at real time, the second time lag can be defined as equal of the first one or 1/N of it. The events in NO.1 prime implicant may happen, as the previous valve actuator action should be "close" when the thermal load "WP2" of SPU1-4 is zero at some periods during the experiment. If the valve needs to be maintained at open status during the mission time, the second time lag should be defined based on the rack operating profiles.

## 6. Future work

Future work should be concentrated on two aspects: 1) the discretization of process variable nodes, 2) the autonomous search for the prime implicants for the fault diagnosis.

The threshold of one variable should be defined as the set point in the abnormal condition detection algorithms. The nominal ranges for temperature or flow in each testing point are different. They should be defined clearly so that the measured value of one variable can correspond to the state of the process variable node in the DFM model.

The top events as defined in the DFM model can be deductively analysed to get a series of prime implicants. The analytical results will be added into the IHM module and called by fault diagnosis algorithms. The fault diagnosis is the process of autonomous search for the causes of certain event.

## References

- Aldermir T, Guarro S, Kirschenbaum J, Mandelli D, Mangan LA, Bucci P, 2009, A benchmark implementation of two dynamic methodologies for the reliability modelling of digital instrumentation and control systems (Nureg/Cr-6985), Nuclear Regulatory Commission, Washington, DC, U.S..
- Aldemir T., Guarro S., Mandelli D., Kirschenbaum J., 2010, Probabilistic risk assessment modelling of digital instrumentation and control systems using two dynamic methodologies, Reliability Engineering and System Safety, 95, 1011-1039.
- Goebel K., Yan W., 2008, Correcting sensor drift and intermittency faults with data fusion and automated learning, IEEE systems journal, 2 (2), 189-197.
- Hill S. A., Kostyk C., Motil B., Notardonato W., Rickman S., Swanson T., 2010, Draft thermal management systems roadmap, NASA headquarters, Washington, DC, U.S..