



On the Use of Dynamic Process Simulators for the Quantitative Assessment of Industrial Accidents

Gabriele Pannocchia, Gabriele Landucci*

Dipartimento di Ingegneria Civile e Industriale, Università di Pisa, Largo L. Lazzarino 1, 56126 Pisa (Italy)
 g.landucci@diccism.unipi.it

The present work discusses the use of dynamic process simulators as supporting tools for the quantitative risk assessment of industrial facilities. In particular, a commercial process simulator was set up for the analysis of industrial accidents, obtaining on one side a detailed characterization of the source term in case of release events from process equipment or pipes. On the other, the possibility of implementing in the simulator control actions, interlocks, emergency shut-down, allowed monitoring the response of a given process unit, verifying the effectiveness and robustness of safety devices in emergency situations. The application to two case studies was used to demonstrate the potentialities of dynamic process simulators in the framework of industrial safety analyses.

1. Introduction

The evaluation of accidental scenarios in the framework of quantitative risk analysis (QRA) is often carried out with simplifications (CCPS, 2000). This is due to the high number of scenarios considered in a typical QRA study (Uijt de Haag and Ale, 1999) and the uncertainties affecting the release schematization (Lees, 1996). Hence, a reference duration and a constant release rate are often defined for standard LOC (Loss Of Containment) events (Van Den Bosh and Weterings, 1997). This may lead to some overly conservative predictions (Lees, 1996), without considering the actual evolution of the accidental scenarios, neither assessing the effect of possible post-release mitigations, alarms, interlocks, etc. (Tugnoli et al., 2012).

Process simulators are nowadays consolidated tools for the analysis of industrial processes, e.g. in the chemical, petrochemical and Oil&Gas (O&G) industries. Those tools, are often used to design or analyze a process in steady state conditions, taking account advanced thermodynamic modeling for multicomponent systems, the features of the more common types of equipment and thus obtaining the quantification of the heat and material balance. Moreover, dynamic process simulators ensure the detailed analysis in transient conditions (e.g., analysis of the system response to a given control action or implementing interlocks or different control logics, etc.) but their application in safety studies is not yet consolidated.

In the present work, a commercial process simulator, Honeywell UniSim® Design, was applied for the analysis of accidental scenarios in order to perform a detailed evaluation of dynamic response of a given process unit. On one side, this was aimed at obtaining a more precise characterization of the source term in case of accidental release from process equipment or pipes. On the other, the possibility of implementing control actions, interlocks, emergency shutdown, allowed monitoring the response of the system, verifying the effectiveness and robustness of safety devices in emergency situations, in the perspective of a safety based design, supporting sustainable process development (Tugnoli et al., 2011).

In order to provide an exemplification and to test the potentialities of the simulator, two accidental situations associated with a three-phase separator are defined and analyzed in the next sections.

2. Methodology description and definition of case studies

2.1 Dynamic process simulators: potentialities for quantitative analysis in accident scenarios

The use of process simulators permeates many aspects on design and operation on industrial process systems. Steady-state process simulation is widely used for conceptual process design purposes and

preliminary equipment sizing. It is also largely adopted for process optimization aimed at maximizing the process operational profit (Lam et al., 2011). The key aspects of a process simulator that allows one to obtain such goals are a high-fidelity library of chemical species, mathematical models describing commonly used unit operations, and embedded numerical nonlinear optimization algorithms.

On the other hand, dynamic simulation is particularly useful in control system design and maintenance of both decentralized and advanced control systems (Pannocchia et al., 2013). The main benefits of dynamic simulation compared to actual plant testing are associated with a reduction of controller commissioning time and minimum upsets to production continuity (Conroy and Mathur, 2003). Dynamic process simulators are hence able to manage start-up, shut-down, and can support the design or the operation of plant in the entire lifecycle.

Recent works highlighted a less conventional utilization of process simulators in the framework of industrial accident analysis (Manca and Brambilla, 2009). Results obtained showed some of the potentialities of these tools in obtaining dynamic data of process equipment during accidental or unwanted situations.

In the framework of consequence analysis and source term characterization, simplifying and worst-case assumptions are usually made (Lees, 1996). As a matter of fact, given a rupture category, gas or liquid release flow rates are evaluated assuming constant pressure in the source piece of equipment. Hence, the maximum flow rate, i.e. the one evaluated at the beginning of the release, is considered for a fixed time lapse. Moreover, accidental pressurization of equipment leading to leaks from gaskets and seals are usually analyzed without considering the dynamic of the phenomenon and the response of control or mitigation barriers. This may lead to an overestimation of the release severity, with amplification of the expected consequences (Van Den Bosh and Weterings, 1997). Given the uncertainty affecting the considered models (Lees, 1996), this framework is usually valid, but in the case of critical and sensitive pieces of equipment more detailed analysis might be a driver for the design or verification of protection systems (Tugnoli et al., 2007).

In this work we exploit a number of specific features of the dynamic process simulator Honeywell UniSim® Design R400 (Honeywell, 2010a) to obtain accurate predictions of the liquid and gas release during accidental situations and to test the effectiveness of the control systems and of the safety procedures and protections.

High fidelity of the simulation results comes firstly from a rigorous treatment of the thermodynamics of the streams involved in the process (Honeywell, 2010b). This aspect is proved successful particularly in the O&G and refining processes as Honeywell UniSim® Design contains natively all organic species of interest (hydrocarbons) along with all other inorganic species typically involved (e.g., N₂, CO₂, H₂S, etc.). Moreover, it is possible to define hypothetical components (termed "Hypo" components) to represent species not natively present or to lump a number of species into a single component (e.g., very heavy hydrocarbons). Honeywell UniSim® Design has many different thermodynamic correlations among which the user can choose. For most processes in the O&G industries such a choice is not difficult because the standard correlations (e.g. the Peng-Robinson equation of state) are very well suited. However, for more specific processes, this choice can be problematic and may require some adjustments of the model parameters in order to match the thermodynamic predictions with available experimental data (see e.g., Landucci et al. 2013).

The second aspect that makes process simulators so useful is the available detailed models of all common unit operations (vessels, heat exchangers, distillation and absorption columns, etc.). Such models do not make stringent simplifying assumptions and can take into account the actual geometry of each piece of equipment, including e.g. the locations and dimensions of vessel buffers, the size and type of control and safety valves. Differently from steady-state models, in dynamic simulations (Honeywell, 2010c) the actual dimensions of each piece of equipment are exploited to take into account rigorously the relation among pressure and flow rate, as well as the associated thermal effects that occur (e.g., the Joule-Thompson effect in valves).

Thirdly, in dynamic simulations it is possible to replicate the control logics and algorithms very accurately, e.g. by specifying the valve characteristics, controller tuning, as well as possible malfunctions such as valve friction, losses in instrumental air pressure, etc. It is also possible to define suitable triggers for specific events, and this is particularly useful for studying accidental situations that activate the closure of shutdown valves.

2.2 Two case studies

In order to illustrate the potentialities of dynamic simulators, we selected a typical Oil & Gas unit, namely a three phase separator, treating various inlet streams featuring hydrocarbon components from C1 to C20+, as well as an aqueous phase containing water and ethylene glycol (EG). The aim of this process unit is the separation of the gas, the condensate (i.e., the liquid hydrocarbon phase) and the aqueous phase. Figure

1 shows the Process Flow Diagram (PFD) of the separator considered in the present analysis (labeled as VS-1). The considered piece of equipment is a horizontal separator which operates at 20 bar and 15 °C; it is provided with a calming baffle at the entrance of the raw gas and with a mist eliminator on the gas outlet nozzle. An internal weir is provided in order to perform the separation between condensate and the aqueous phase (indicated as "WAT" in the PDF).

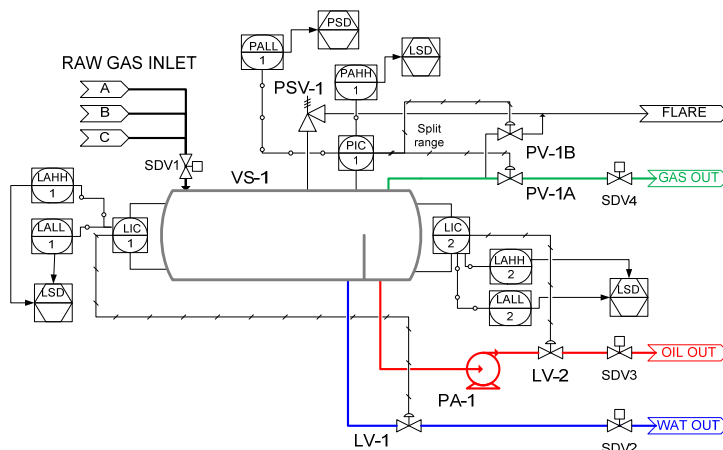

Figure 1. Process Flow Diagram of the separator unit.

As shown in Figure 1, three main inlet streams (labeled with "A", "B" and "C") are collected into an inlet manifold and sent to VS-1. The inlet gas phase is essentially composed by methane (C1) and low molecular weight hydrocarbons (C2-C4), having a total flow rate of about 2,194 kg/h. The condensate flow rate is 28.9×10^3 kg/h, and it is constituted by mainly C5-C20+ hydrocarbons, while the aqueous phase flow rate is 907 kg/h, with a mass ratio water/EG equal to 1.87.

The production separator is operated under split range pressure control PIC-1 on gas phase. Flashed gas is routed through a pressure control valve PV-1A to downstream units. In case of overpressure or downstream units unavailability, the excess gas is conveyed through a pressure control valve PV-1B to the flare system.

The aqueous stream is discharged, under level control LIC-1 that acts on control valve LV-1 to control the water-oil interface, to the water treatment section. Liquid hydrocarbons level is controlled by a level controller LIC-2 that acts on the LV-2 installed on the feed line to condensate stabilization, provided with the pump PA-1.

Table 1: Summary of features and triggers associated to control and safety devices

Safety device	Trigger/Feature	Value	SI unit
Pressure Safety Valve PSV-1	Set pressure	21.6	bar
Pressure Safety Valve PSV-1	Valve size F*	-	
Split range control	Set pressure	21.0	bar
Very high pressure alarm PAHH1	Set pressure	24	bar
Very low pressure alarm PALL1	Set pressure	18	bar
Very low interface level alarm LALL1	Set level**	0.20	m
Very low condensate level alarm LALL2	Set level**	0.40	m
Very high interface level alarm LAHH1	Set level**	0.65	m
Very high condensate level alarm LAHH2	Set level**	1.30	m

* See specific safety valve features in (Honeywell, 2010a)

** The level is taken considering the height of liquid or interface respect to the bottom of the separator

The separator is equipped with interlocks and safety devices summarized in Table 1. In particular, in case of accidental pressurization of VS-1, besides the split range pressure control, a high pressure alarm PAHH1 activating the Local Shut Down (LSD) and a pressure safety valve (PSV-1) are installed as further protections. The PSV is also designed for external fire contingency. The LSD activates four Shut Down Valves (SDVs): SDV1 on the inlet feed, SDV4 on the treated gas exit, SDV2 and SDV3 respectively for the

aqueous phase and condensate exit lines. In case of severe depressurization (e.g., caused by accidental leaks or ruptures) the Process Shut Down (PSD) is triggered by the very low pressure alarm (PALL1) closing the mentioned SDVs in order to limit the eventual amount of spilled flammables. In order to prevent the oil entrainment in the aqueous phase, the LSD is triggered by very low interface level LALL1. The LSD is also triggered by very low condensate level LALL2 in order to prevent the gas blow-by. In case of both interface and condensate level accidental increment, LAHH1 and LAHH2 will both activate the LSD.

Table 1 reports the features and the triggers associated to the mentioned alarms and safety devices.

For the process unit previously described, two accidental situations were taken as reference case studies and analyzed with the process simulator. Figure 2 shows the PDF built in Honeywell UniSim® Design to analyze the case studies.

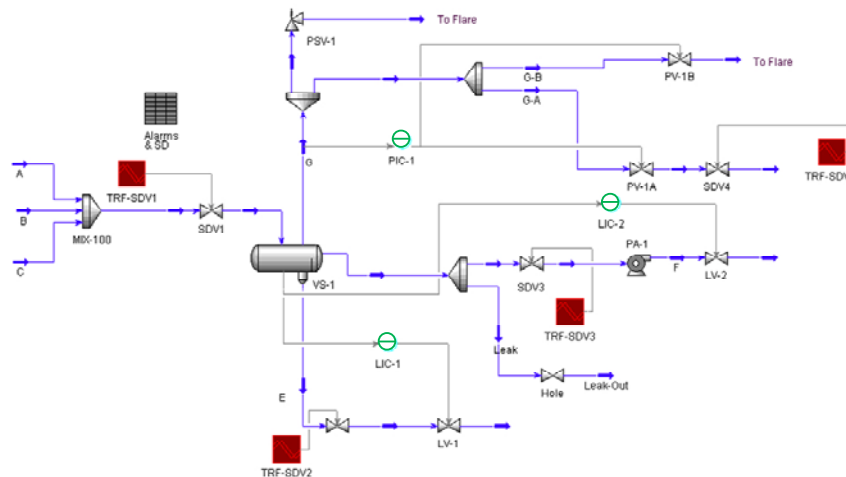

Figure 2. Process Flow Diagram of the separator unit build in Unisim® Design .

In the first case, the simulator allowed monitoring the pressure build up in the separator and testing the adequateness of the available protections for the vessel accidental pressurization. The protections were activated in sequence at different set pressures, as shown in Table 1. A downstream pressure build up (imposing up to 8 bar increase in six minutes in the stream at the discharge of SDV4 in Figure 2) allowed simulating the system pressurization caused by unavailability of downstream units. The response of pressure control in split range, very high pressure alarm triggering LSD, and finally emergency discharge through the PSV were thus evaluated. The results of this case study are discussed in Section 3.1.

In the second case, the simulator allowed taking into account the depressurization of the vessel caused by a 1" equivalent diameter rupture in the vessel shell on the condensate side. The case study was aimed at providing the transient evaluation of the flammables release rate and assessing the intervention of safety interlocks (LSD) connected to very low condensate level and very low pressure. As shown in Figure 2, the rupture is simulated introducing a fictitious tee-line in the condensate exit, in which one end is normally closed by the valve "Hole", which is set by the simulator to the fully open position when the leak starts. The valve is sized, specifying conductance $k=51 \text{ (kg/h)/(kPa kg/m}^3)^{0.5}$ (see Honeywell 2010c for the specific flow relation) in order to obtain the maximum flow rate as estimated by literature outflow models (Van Den Bosh and Weterings, 1997). The results of this case study are discussed in Section 3.2.

It is worth mentioning that the control and safety devices installed on the separator might be unavailable and thus fail on demand in case of emergency (e.g., valves blocked open, wrong signal from the control system, missing alarms, etc.). Analyzing the possible failures of control or protection systems is at the moment out of the scope of the work, hence for simplicity the complete efficiency and availability of all considered control and safety barriers was assumed. However, it is possible In UniSim® Design to simulate scenarios in which control and safety devices fail.

3. Results and comments

3.1 Case study 1

The results of case study 1 are summarized in Figure 3.

In this scenario we assume that the discharge pressure increases by 8 bars in six minutes, starting at time 5 min. We observe that PV-1A opens to attempt to compensate the pressure increase, and after the pressure reaches 21 bar, PV-2A also starts to open and discharges the gas to the blow down system. Even when both valves are fully open, the vessel pressure exceeds 21.6 bar and consequently PSV-1 opens and discharges gas to the blow down system. It is also interesting to note that the production rate decreases (and eventually becomes zero because all gas is discharged to blow down by PV-1B and PSV-1) whereas the condensate rate initially increases until PSV-1 opens. From these results we observe that the split range pressure control system and the additional protection of PSV-1 guarantee a large extent of robustness to pressure trips of downstream units. Therefore, the present case study demonstrates the potential application of process simulators in investigating the effectiveness of active and passive overpressure protection systems of industrial equipment. The evaluation of the mass rate variation in the blow down and emergency discharge lines may constitute an advanced verification tool for the standard rules which usually drive the sizing and design of these systems (e.g., API RP 520, API RP 521) and to characterize the response of the downstream flare loading conditions.

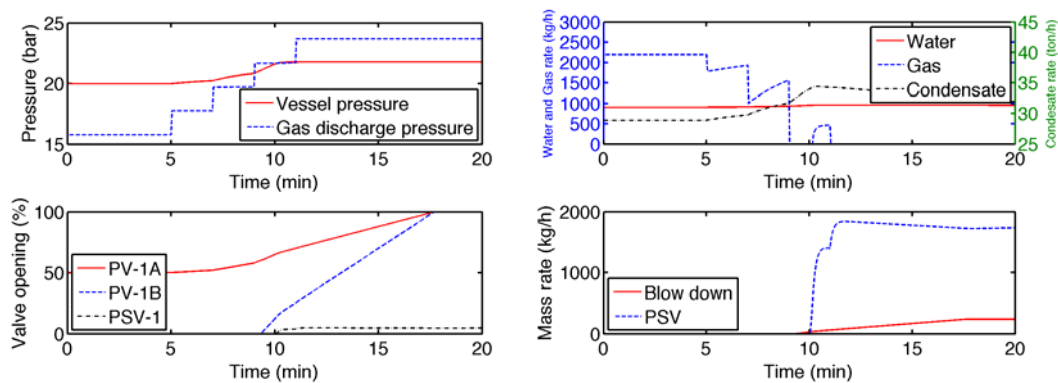

Figure 3: case study 1: response of the process to an increase of pressure downstream of the gas line

3.2 Case study 2

The results of Case study 2 are summarized in Figure 4.

We observe that as soon as the vessel hole occurs (at time 5 min), the leak rate reaches a steady value (e.g., 57 t/h). Meanwhile the HC liquid level in the right chamber decreases rapidly. The level controller LIC-2 tries to compensate this level decrease by closing the associated valve LV-2 and consequently the condensate production rate decreases. A minor decrease of gas rate is also experienced due to a small decrease of vessel pressure. Approximately at time 10 min, i.e. five minutes after the leak occurs, the HC level falls below the set value for alarm LALL2, and this alarm initiates the shutdown of all four SDVs (only SDV-1 is depicted in Figure 4), which fully close in 3 minutes. This action effectively isolates the vessel and causes a dramatic decrease of the leak rate.

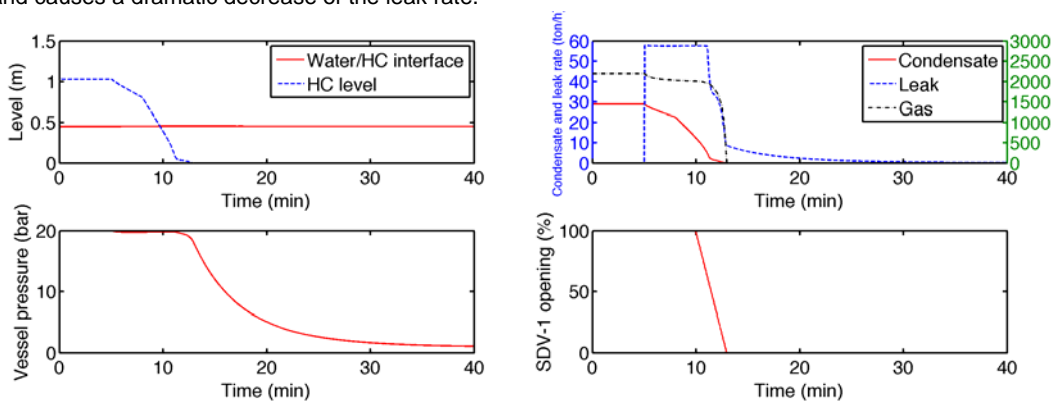

Figure 4: case study 2: response of the process to an accidental condensate leak caused by the rupture of the separator shell

Hence, the simulator allows determining the dynamic response of the system in case of accidental depressurization and release of hazardous materials. On one side, this may be used as verification tool for the emergency interlocks, and more in general, for the assessment of automatic safety devices response (e.g., active protection systems).

Moreover, the outcomes of the simulator, in terms of predicted release rate and duration, may be used to obtain an advanced characterization of the source term for the considered accidental leak. This allows a more realistic consequence evaluation in case of mitigation systems availability and effective response.

4. Conclusions and future works

In the present work, the potentialities of dynamic process simulators in analyzing accidental situations of process units were discussed. In particular, the commercial simulator Honeywell UniSim Design® was applied for the analysis of specific case studies in which typical accidental situations, such as equipment pressurization and liquid hydrocarbons outflow, were considered.

The case studies showed the potential application of process simulators for the detailed characterization of the source term in case of accidental release from process equipment or pipes, and for the system response evaluation, taking into account the activation of control actions, interlocks, shut-down and, more in general, safety devices.

A promising development of this activity may be related to the analysis of more complex processes, investigating interactions among units and blow down system during emergency depressurization, in order to verify their effectiveness and robustness. Moreover, in the framework of Quantitative Risk Assessment studies, process simulators may support the advanced source term evaluation in presence of mitigation barriers, which are often neglected or taken into account with simplified assumptions. This study may be integrated with the availability analysis of the mitigation and protection barriers in order to achieve a more realistic risk profile associated to critical equipment items.

References

- Center for Chemical Process Safety - CCPS, 2000, Guidelines for Chemical Process Quantitative Risk Analysis. AIChE, New York, USA.
- Conroy, R.J., Mathur U., 2003, Successful multivariable control without plant tests: First-principles dynamic simulation models can be used instead, *Hydrocarbon Processing*, 82(4), 55-58.
- Lees F.P., 1996, Loss Prevention in the Process Industries, 2nd ed., Butterworth Heinemann, Oxford, UK.
- Honeywell, 2010a, UniSim Design® – User Guide, Honeywell, London, Ontario (Canada).
- Honeywell, 2010b, UniSim Design® – Simulation Basis Reference Guide, Honeywell, London, Ontario (Canada).
- Honeywell, 2010c, UniSim Design® – Dynamic Modeling Reference Guide, Honeywell, London, Ontario (Canada).
- Landucci G., Pannocchia G., Pelagagge L., Nicoletta C., 2013, Analysis and simulation of an industrial vegetable oil refining process, *J. of Food Engineering*, 110(4), 840–851.
- Lam H.L., Klemeš J.J., Kravanja Z., Varbanov P.S., 2011, Software tools overview: process integration, modelling and optimisation for energy saving and pollution reduction, *Asia-Pacific J. of Chem. Eng.*, 6, 696–712.
- Manca, D., Brambilla, S., 2009, Dynamic simulation of industrial accidents, *Chemical Engineering Transactions*, 17, 299-304, DOI: 10.3303/CET0917051.
- Pannocchia G., Bottai M., De Luca A., 2013, Application of a Method to Diagnose the Source of Performance Degradation in MPC Systems, *Chemical Engineering Transactions*, 32, 1189-1194, DOI:10.3303/CET1332199.
- Tugnoli A., Landucci G., Cozzani V., 2007, A consequence based approach to the quantitative assessment of inherent safety, *AIChE J.*, 53, 3171-3182.
- Tugnoli A., Santarelli F., Cozzani V., 2011, Implementation of sustainability drivers in the design of industrial chemical processes, *AIChE J.*, 57(11), 3063-3084.
- Tugnoli A., Landucci G., Salzano E., Cozzani V., 2012, Supporting the selection of process and plant design options by Inherent Safety KPIs, *J. of Loss Prevention in the Process Industries*, 25(5), 830-842.
- Uijt de Haag P.A.M., Ale B.J.M., 1999, Guidelines for Quantitative Risk Assessment (Purple Book), Committee for the Prevention of Disasters, The Hague, The Netherlands.
- Van Den Bosh, C.J.H. and Weterings, R.A.P.M., 1997, Methods for the calculation of physical effects (Yellow Book), Committee for the Prevention of Disasters, The Hague, The Netherlands.