

Thermal Analysis of the Finned Channel of Pneumatic Pulsator Using Numerical Simulations and Thermography

Jacek Wernik*, Krzysztof J. Wołosz

Department of Process Equipment, Warsaw University of Technology, Plock Branch, Al. Jachowicza 2/4, 09-402 Plock, Poland
 wernik@pw.plock.pl

The research on heat conduction through the finned channel of pneumatic pulsator was discussed. Rectangular fins are located on the channel.

3-D model of the channel was created. The developed model of 3-D channel of an industrial pulsator has been imported into COMSOL Multiphysics. This program is the environment for modelling and solving scientific and engineering problems based on partial differential equations. As a result, the solution was obtained in the form of temperature distribution on finned channel of pneumatic pulsator and the temperature distribution of the air flowing over the pulsator.

Numerical methods are subject to certain errors, hence it is essential to verify the results.

Real object were subject to thermographic tests in order to verify the correctness of the numerical model. The FLIR SC7600 camera was used. Non-contact diagnostic method based on the observation of infrared radiation has enabled visualization, registration and interpretation of temperature distribution on the surface of the tested channel. The resulting thermal images were compared with the temperature distributions designated using a computer.

The use of thermography in laboratory tests to validation numerical models is possible. Therefore, when designing new devices, both techniques can be used methodically.

1. Introduction

Currently, numerical simulations have become a tool that is widely used both in research and engineering applications. The results obtained from numerical simulations provide a basis for the design of industrial apparatus, and also the optimisation of industrial processes. In research, numerical methods are broadly applied to confirm the validity of proposed theoretical models. Numerical methods often replace experimental investigations, which is related to the fact that experimental tests are time-consuming and they require substantial financial outlays. The issues related to the accuracy, quality and reliability of the results produced with numerical simulations are therefore of crucial importance. The problems concerning the accuracy of computations are presented by Oberkampf and Roy (2013).

To evaluate the accuracy and reliability of simulations results, it is necessary to perform validation and verification. Those two notions are inherently related to numerical methods and commonly used in research. Verification is meant to check whether the equations describing a given model have been solved correctly, whereas validation is needed to find out if the solved equations describe a given phenomenon correctly. Generally, it is agreed that the use of numerical methods should involve three separate stages:

- Formulation of the problem on the basis of the description of physical phenomena,
- Mathematical description, i.e. defining partial differential equations, adopting assumptions and stating boundary conditions,
- Numerical solution.

Validation is responsible for the first stage, whereas verification concerns the second and the third stage. Roache (1997) proposed that verification should precede validation. As a result, the physical description stage does not contain errors and inaccuracies that originate from numerical simulations.

The paper presents the manner, in which experimental investigations employing thermovision camera can be employed to make validation of the results of numerical simulations. The object of concern was a finned channel of the pneumatic pulsator. The principle of operation of the pneumatic pulsator was presented by Wołosz and Wernik (2012). First studies, in which thermovision was used, confirmed that technique provides an effective tool to check the reliability of numerical simulations of the pneumatic pulsator (Wernik and Wołosz, 2015). The methodology of the approach involving thermovision and numerical simulations applied to finned casing was presented by Urbaniec et al. (2015).

2. Numerical model of pneumatic pulsator

2.1 Preliminary assumptions

A special approach was adopted to devise an appropriate numerical model of the pneumatic pulsator channel. That involved comparing computer simulations performed using COMSOL Multiphysics package with measurements taken for a channel segment of the actual device. The Finite Element Method is one of the tools most frequently used for building approximate numerical models. The method makes it possible to seek solutions to partial differential equations after those have been discretized using the element mesh. Element meshes are considered to be fragments of discretized area, which have homogeneous properties. The fundamentals of the Finite Element Method were presented in (Reddy and Gartling, 2010), whereas application examples were given by Baskharone (2014). Figure 1 shows the examined numerical model of the pneumatic pulsator with the channel segment. Geometry was accounted for using the CAD tools of the COMSOL Multiphysics software.

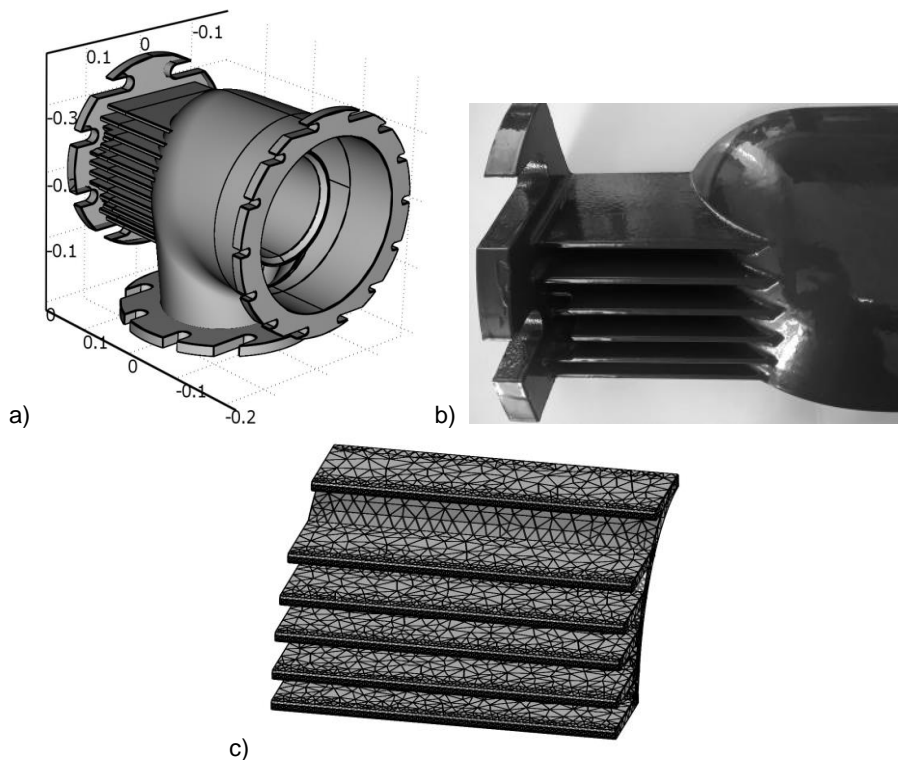

Figure 1: Geometry of the modelled device: a) 3-D model b) actual channel segment c) mesh of the channel segment of concern

The data on mesh properties are presented in Table 1. In the actual pulsator, heat is released inside the channel, which causes friction of the flowing air against the walls.

Table 1: Mesh statistic

Number of degrees of freedom	Number of tetrahedral elements	Number of mesh points
96,496	55,447	16,177

2.2 Heat transfer conditions

Simulations were performed for three cases, in which the variable was an average value of temperature on the internal channel surface. Heat from the channel surface is transferred by means of free convection. Therefore, it is important that the value of the convective heat transfer coefficient into the surroundings is calculated correctly. The determination of correct coefficient values is by no means an easy task, and researchers still continue to study those issues (Chow et al., 2015). In a general case, the intensity of convective heat transfer can be expressed by equation:

$$h=q/(T_{ext} - T_{amb}) \quad (1)$$

where h is convective heat transfer coefficient, q represents heat losses on the surface, T_{ext} and T_{amb} are external and ambient temperatures, respectively.

For free convection, generalised dependence based on criterion numbers, namely Grashof (Gr), Prandtl (Pr), Nusselt (Nu), is commonly used. The dimensionless form of coefficient h is the Nusselt number:

$$Nu=C(GrPr)^c \quad (2)$$

where coefficients C and c depend on the value of $GrPr$ product.

Bergman et al. (2011) claim that the dependence can be applied to most engineering applications. The values of computed dimensionless numbers found in Eq.(2), and also the values of convective heat transfer coefficients determined from Eq.(1) for three cases of concern, are listed in Table 2. Coefficients C and c were 0.54 and 0.25, respectively.

Table 2: Evaluated dimensionless numbers and convection coefficients

	1	2	3
Temperature at the channel surface, K	300.9	312.4	315.4
Grashof number, Gr	22,595	52,947	56,418
Prandtl number, Pr	0.715	0.714	0.714
Nusselt number, Nu	6.08	7.53	7.65
Convective heat transfer coefficient, h $W/(m^2K)$	5.19	6.42	6.53

2.3 Boundary conditions

For numerical simulations, the following values were assumed:

- coefficient of thermal conductivity k for aluminium: 180 $W/(mK)$,
- ambient temperature: 293 K ,
- convective heat transfer coefficients into the surroundings, for three cases, acc. Table 1.

All external channel surfaces that are in contact with ambient air are cooled by means of natural convection. Those are described by the expression:

$$-\left(k \frac{\partial T}{\partial n}\right) = h(T_{ext} - T_{amb}) \quad (3)$$

where k denotes thermal conductivity, $\frac{\partial T}{\partial n}$ is temperature derivative along the direction normal to the isothermal surface. All the pre-defined boundary conditions were mapped onto the designed computational model shown in Figure 1c, also appropriate physical constants for aluminium were adopted.

3. Investigations with the use thermovision camera

Figure 2 shows the way investigations using thermovision camera were conducted. Air heater 4 was the source of thermal power. To measure air velocity, VelociCheck Air Velocity Meter 8330 was installed before the channel, at the distance of 20 mm. Temperature changes were observed using FLIR SC7600 camera, for which noise-equivalent temperature difference (NETD) is 20 mK. From the camera, the signal was passed to

PC, which generated thermograms of a given channel under specified heat transfer conditions. The emissivity of the channel surface was determined experimentally by means of a comparative measurement with a surface with constant emissivity, which is known. The surface of 3M™ Scotch® Super 33+ insulation tape was chosen as the reference surface satisfying the conditions set above. Comparative measurement for the painted radiator surface made it possible to estimate emissivity value at 0.96. The interpretation of thermograms is a vital issue involving a thorough analysis of the monitored phenomena and properties of the object (Marinetti and Cesaratto, 2012).

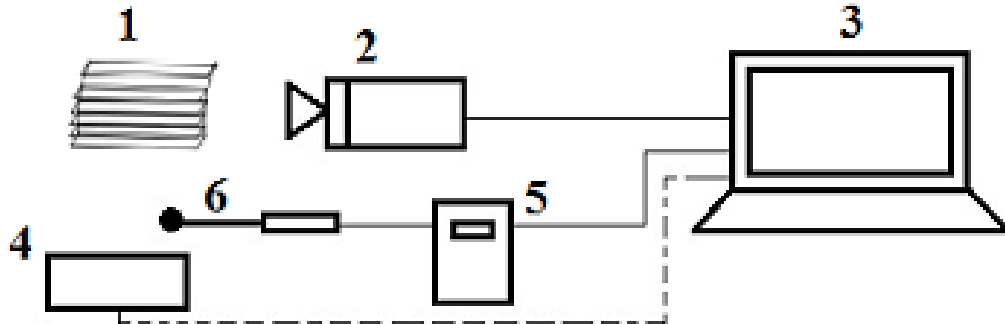

Figure 2: Arrangement of the measurement stand. Notation: 1. Channel 2. Thermovision camera 3. PC 4. Air heater 5. Anemometer 6. Probe. A dashed line represents manual transfer of information

4. Results

4.1 Numerical simulations

Numerical simulations produced spatial distributions of the field of physical parameters of the radiator model of concern, which had the form of vector values. Figure 3 shows an exemplary temperature distribution on the channel surface for case 1 (Table 1). The results of temperature distribution presented in Figure 3 allow accurate reading of the temperature distribution field. The results received for three cases should not terminate the problem-solving procedure. The results obtained are almost always marred by errors, and therefore should be subjected to validation.

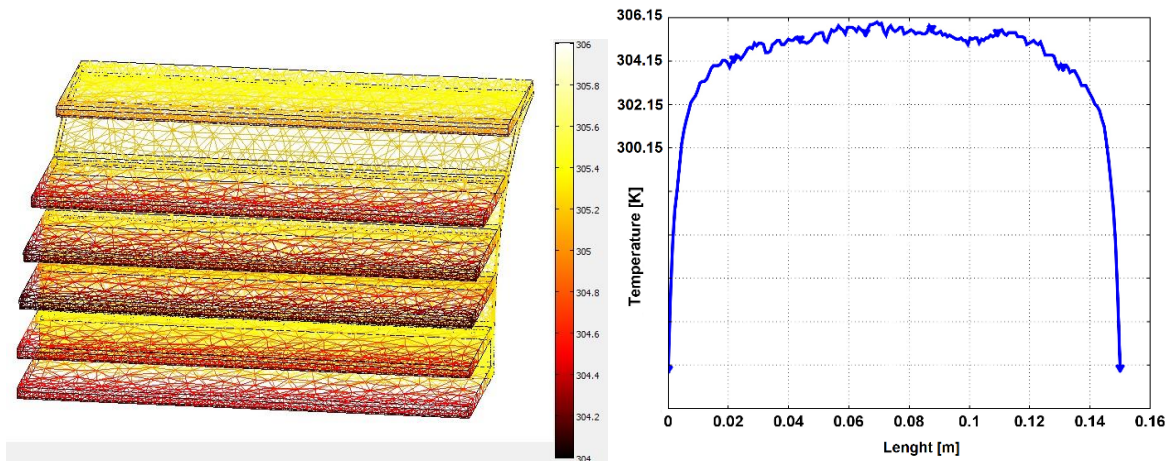

Figure 3: Temperature distribution on the surface of the channel

4.2 Experimental investigations with the use of thermovision

Investigations with the use of a thermovision camera were conducted at ambient temperature of 293 K. The thermograms obtained in the investigations allowed the determination of actual temperature values on the channel surface. The set of temperature values was used to determine the average temperature on the channel surface. Averaged temperature values for three cases were employed to determine the value of convective heat transfer coefficient. Figure 4 presents an exemplary thermogram for average (300.9 K) temperature of the channel surface. Temperature values at individual points, obtained through measurements, can be easily imported so that they could be represented in the distance (originally expressed in pixels) –

temperature (given in K) system. Line 1 in Figure 4 corresponds to the site from which the data were collected, and which were presented in the form of a graph in Figure 5.

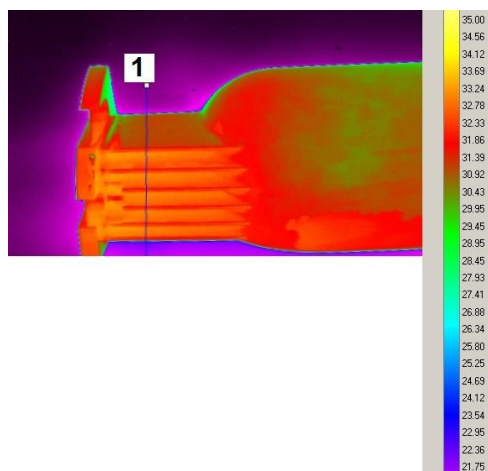

Figure 4: Surface channel thermogram

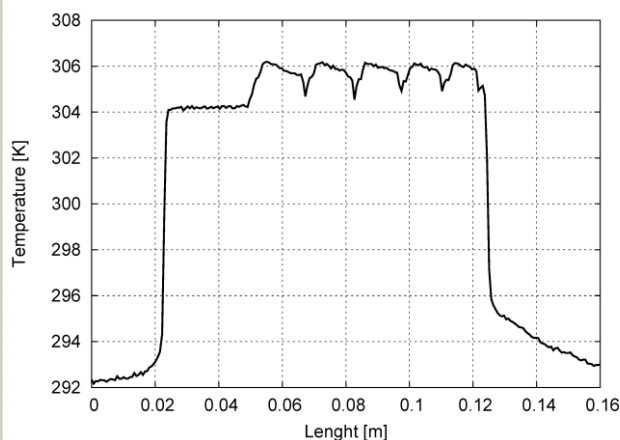

Figure 5: Temperature distribution along the selected line

5. Conclusions

Numerical methods, especially Finite Element Method, have been widely used for decades, but those give only approximate results. The aim of investigations conducted for this study was to perform the validation of results obtained from numerical simulations, which was done using thermography. The investigations were conducted, in two stages, on the segment of the pneumatic pulsator channel, under free convection conditions. Experimental measurements and numerical simulations were performed for three values of thermal power. Measurements taken with the thermovision camera made it possible to determine the values of channel surface temperature, and to average those values. Temperature values were used to calculate, from empirical dependences, the values of convective heat transfer coefficients. Accurate calculation of the values of convective heat transfer coefficients is of crucial importance for defining appropriate boundary conditions. The comparison of temperature distributions obtained using FEM and those received at the experimental stand indicates that heat conduction and heat convective can be well described by numerical simulations conducted with COMSOL Multiphysics software. As regards engineering applications, dependence (2) produces satisfactory results. The numerical model of the channel, tested in the study, makes it possible to conduct further investigations for forced convection conditions. To this end, it is necessary to slightly modify the experimental stand, and to equip it with a fan. On the basis of the tested numerical model of the pneumatic pulsator channel, it is possible, eventually, to carry out the analysis of thermal stress.

References

- Oberkampf W.L., Roy Ch.J., 2013, Verification and Validation in Scientific Computing. Cambridge University Press, UK, DOI: 10.1017/CBO9780511760396.
- Roache P.J., 1997, Quantification of uncertainty in computational fluid dynamics, Annual Review of Fluid Mechanics, 29, 123-160, DOI:10.1146/annurev.fluid.29.1.123.
- Wołosz K.J., Wernik J., 2012, Pneumatic pulsator design as an example of numerical simulations in engineering applications, Central European Journal of Engineering, 2(1), 76-82, DOI: 10.2478/s13531-011-0050-5.
- Wernik J., Wołosz K.J., 2015, Study of Heat Transfer in Fins of Pneumatic Pulsator Using Thermal Imaging, Chemical Engineering Transactions, 45, 985–990, DOI:10.3303/CET1545165.
- Urbaniec K., Wernik J., Wołosz K.J., Grabowski M., 2015, Thermal analysis of the finned housing of an electric motor using numerical simulation and thermography, Proceedings of the 10th Conference on Sustainable Development of Energy, Water and Environment Systems, Dubrovnik, Croatia, SDEWES2015.0855, 1-6.
- Reddy J.N., Gartling D.K., 2010, The Finite Element Method in Heat Transfer and Fluid Dynamics. CRC Press, Boca Raton, USA.
- Baskharone E.A., 2014, The Finite Element Method with Heat Transfer and Fluid Mechanics Applications. Cambridge University Press, NY, USA.

- Chow J., Zhong Z., Lin W., Kho L., 2015, The development of a simple semi-empirical method to obtain a predictive model of the convective heat loss of a solid surface of practical machine size by finite difference and experimentation, *Applied Thermal Engineering*, 75, 789-799, DOI: 10.1016/j.applthermaleng.2014.10.006
- Bergman T., Lavine A., Incropera F., DeWitt D., 2011, *Fundamentals of Heat and Mass Transfer*, 7th edition, John Wiley & Sons, NY, USA.
- Marinetti S., Cesaratto P.G., 2012, Emissivity estimation for accurate quantitative thermography, *NDT & E International*, 51, 127-134, DOI:10.1016/j.ndteint.2012.06.001.