

# Total Site Integration of a Soybean Biorefinery Using Systematic Optimization Techniques

José F.O. Granjo<sup>a,\*</sup>, Belmiro P.M. Duarte<sup>a,b</sup>, Nuno M.C. Oliveira<sup>a</sup>

<sup>a</sup>CIEPQPF, Department of Chemical Engineering, University of Coimbra, Rua Sílvio Lima — Polo II, 3030-790 Coimbra Portugal.

<sup>b</sup>Instituto Politécnico de Coimbra, ISEC, Department of Chemical and Biological Engineering, Rua Pedro Nunes, 3030-199 Coimbra, Portugal.  
[josegranjo@eq.uc.pt](mailto:josegranjo@eq.uc.pt)

This contribution addresses the optimal design of the heat exchanger network (HEN) for an integrated soybean biorefinery plant which encompasses six process areas: (i) beans preparation; (ii) oil extraction; (iii) miscella distillation; (iv) soy oil refining; (v) sodium methoxide production; and (vi) biodiesel production via homogeneous alkaline transesterification technology. For this purpose, a two-step methodology is employed, where a Total Site Analysis is first carried to estimate the energy targets for the whole process and assess the potential utility co-generation to be distributed to the process sites through the utility system. Subsequently, the HEN design of each site is performed using the Aspen Energy Analyzer, based on a sequential procedure employing Mixed Integer Linear Programming to minimize the HEN total cost. The results obtained reveal that the heat sources in the current process configuration limit the co-generation of utilities, and therefore the process heat waste needs to be preferentially recovered through stream matches within each site. A systematic design procedure is therefore used to identify an optimized HEN configuration, achieving lower utility consumption and lower total heat exchanger area, compared with a previous reference solution. The higher number of heat exchange units of this new design is compensated with the elimination of inter-site streams matches, resulting in a process alternative simpler to implement in practice.

## 1. Introduction

One of the main challenges of the 21<sup>st</sup> century concerns the development of environmentally and economically sustainable forms of generating energy from renewable resources, particularly in the transport sector, where fossil diesel and gasoline are still preeminent commodities. Major factors driving the shift from a fossil-based to a bio-based economy include global warming, the depletion of fossil resources and the supply shocks originated by geopolitical tensions in geographic areas where significant reserves are located. This trend occurs as a result of the search and exploitation of diverse biomass sources and new (more efficient) pathways to manufacture bio-products and biofuels, but also from the retrofit of existing facilities to expand their supply chain through the incorporation of bio-based products in the portfolio. Within this context, the oilseed crop processing industry can have a significant role, given the numerous products and applications that can be devised, from large volume commodities to specialized products. A previous work (Granjo et al., 2015) studied the incorporation of the soybean processing facilities and the sodium methoxide (NaOCH<sub>3</sub>) manufacture process, within a typical biodiesel production plant. With this configuration (here described as the reference or original design), the biodiesel production cost decreased from \$795/t to \$584/t of biodiesel (tb), due to the synergies associated with the production of soy meal, lecithins and soy distillate products. This design could be further improved through the identification of heat and wastewater integration opportunities, reaching a production cost of \$569/t, and a reduction of wastewater generation by almost 10 %. The heat exchanger network (HEN) used was based on the overall identification of key stream matches, providing a solution with performance close to its target values; this design is here described as the integrated process configuration, and the corresponding flowsheet can be found in Granjo et al. (2017). The present study generalizes the design of the HEN for this integrated biorefinery configuration, following a more systematic approach, to improve the previously identified HEN and exploit the

opportunities of inter-site integration. The methodology used includes two stages: (i) a Total Site Analysis (TSA), to locate the heat sources and characterize their recovery opportunities; and (ii) the optimal network design for the individual process sites, compatible with the previous analysis. The remaining parts of the paper include a brief description of the structure of the processes involved (Section 2), the methodology used (Section 3), the main results (Section 4), as well as some final remarks (Section 5).

## 2. Process Description

The complete soy biorefinery plant in Figure 1 is formed by six processing areas, here denoted by A100 to A600. In the preparation area (A100) the soybeans are cleaned, dehulled, cooked and flaked to release the oil from the solid matrix. The oil is leached from the flakes by solvent extraction in area A200, originating the miscella, a mixture of hexane and soy oil, and the bagasse, formed by hexane and defatted flakes. The miscella goes into a distillation area (A300), where the hexane is evaporated and stripped from the oil, which in turn is sequentially submitted to degumming, bleaching and deodorization to produce refined oil (A400). On their turn, the wetted flakes are desolventized to recover the hexane and then grinded, forming white flakes that may be toasted to produce soy meal. Unit operations and typical operating conditions of areas A100-A400 are thoroughly discussed in Erickson (1995). Finally, in area A600 the biodiesel is produced by the transesterification of the refined soy oil, using a methanolic solution of NaOCH<sub>3</sub> prepared in process area A500. The main primary products manufactured are soy hulls, soy flakes, soy oil, lecithin, distillates of the soy oil deodorizer, biodiesel and glycerol. Figure 2 presents the process flow diagram of A500-A600 processes within the integrated biorefinery configuration. Simulation and modeling details can be found in Granjo et al. (2017).

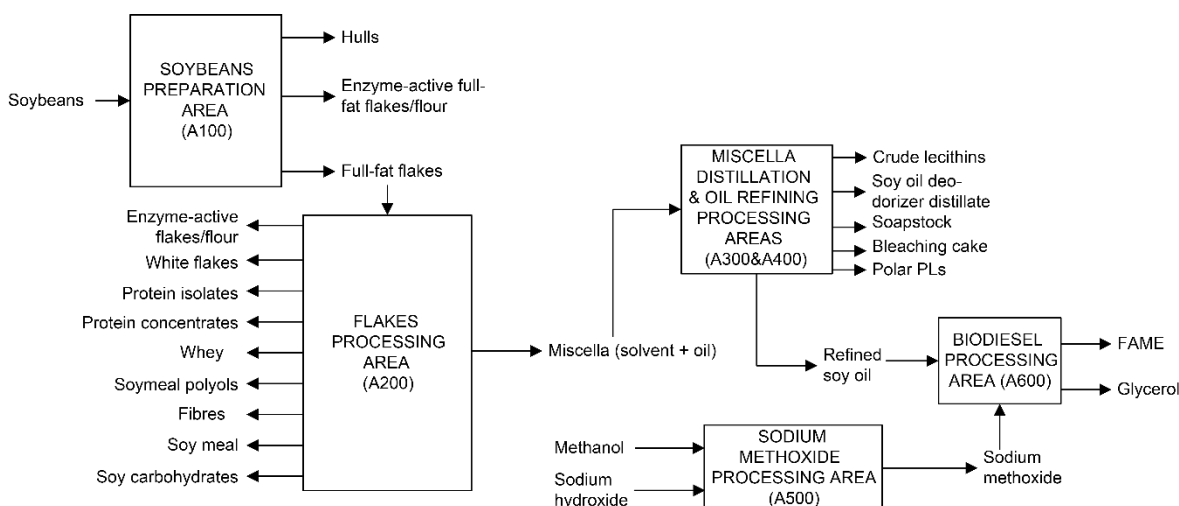

Figure 1: Soybean biorefinery global block diagram and respective main products.

## 3. Methodology

The optimal design of HENs and utility systems in a large-scale plant comprehending several process areas benefits considerably from the use of systematic methodologies to assist in decision-making. This work considers a two-step methodology, where the TSA is first used to provide an overview of the possible integration opportunities, and guide the optimal design of the individual sites, tackled in a second stage. The TSA methodology uses extracted data to build the Grand Composite Curves of each processing area, to locate the Pinch(es) considering the individual minimum approach temperatures ( $\Delta T_{min}$ ), allocate the utilities by their temperature levels, identify the existence of recoverable energy pockets, and determine the heating and cooling targets to be fulfilled by the utilities system (Klemeš, 2013). The consumption and the potential co-generation of hot utilities to be redistributed through the utility system is decided with the support of the Site Source and Sink Profiles. This decision involves the compromise between recovering the available waste heat and the capital cost required to transform and transport it elsewhere on the Total Site.

To complement this analysis, the optimal HEN design for each site is considered in a subsequent phase, employing systematic synthesis strategies. This task is simplified by the fact that the exchanges between the

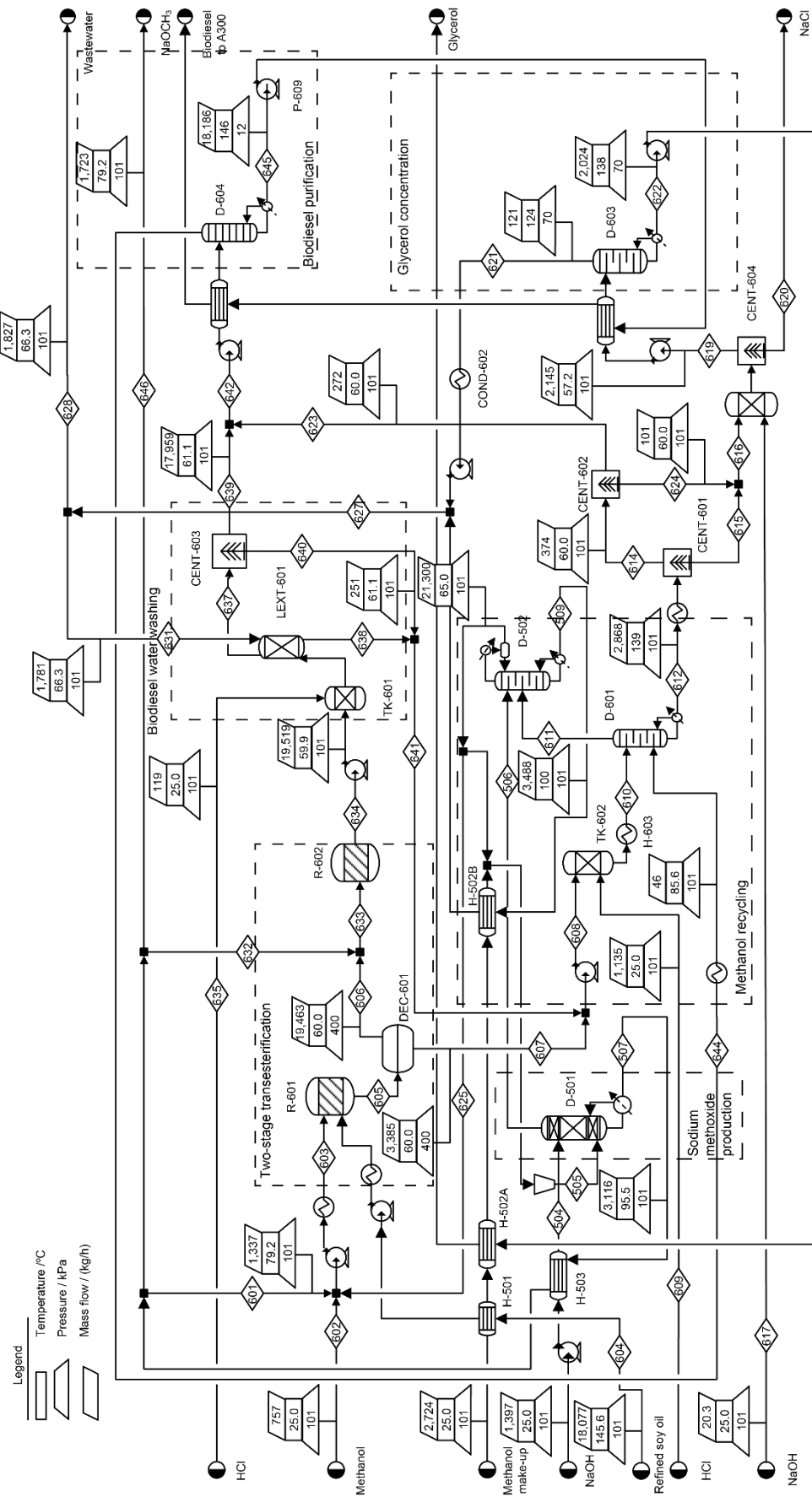

Figure 2: Process flow diagram of A600 and A500 integrated (adapted from Granjo et al., 2017).

sites need to go through the utility system (and are quantified by the TSA), allowing the decomposition of the design problem into HEN designs of each site with inter-site exchange terms fixed. With this strategy, the number of candidate stream matches is greatly reduced, easing the solution of the global design problem.

The HEN design for each site is formulated as the problem of finding the matches between the process and the utility streams that minimize the total cost involved. This was performed using the sequential procedure followed by the Aspen Energy Analyzer (Aspentech, 2010), which consists of (i) solving a Linear Programming problem to optimize the total heat exchange area and heat load for each utility; (ii) formulating a Mixed Integer Linear programming (MILP) problem to simultaneously minimize the number of heat exchanger units, heat exchanger area and the heat loads on each utility; and (iii) building a superstructure similar to Yee and Grossmann (1990), also solved as a MILP, to provide a feasible HEN that satisfies the optimal heat load distribution obtained previously.

#### 4. Results

The Grand Composite Curves of each processing area are represented in Figure 3, where all vent streams were excluded; these have a low heat content and a dew point that makes their heat integration impractical. The cooling utilities in A300 are used to condensate the vapours (hexane and water) of the desolventizing-toasting (DTS) unit, and the hexane vapours from the evaporation and stripping systems. In both A500 and A600, the hot and cooling utilities are mainly required by the recycling of methanol. The DTS unit is responsible for the larger portion of low-pressure (LP) steam consumption in A200. Higher temperatures observed in Figure 3(c) occur near to the deodorization column, where the acid value and the moisture of crude soy oil are reduced.

Total Site Profiles from data extracted by simulation (Granjo et al., 2017) are presented in Figure 4. These profiles show that the heat sources in processing areas A200-A600 cannot be employed to generate steam, since the maximum double shifted temperature (83.6 °C) is below the LP saturation temperature (159 °C). Also, a refrigerant denoted (Ref. #1) needs to be used in the mineral oil cooling system (A300), due to the low temperature that is required (12 °C) to prevent hexane excess in the process vents. These results indicate that the heat recovery opportunities are quite limited with the current process configuration (left side of the graph), and would require the use of an additional low temperature utility, which makes its practical acceptance difficult. However, this analysis may lead to different conclusions when further processing areas are introduced in the biorefinery (such as ethanol production or valorisation of the edible products), due to the different energy requirements of each process. Consequently, this step needs to be repeated after the inclusion of each additional processing area. In the current configuration (Figure 1), heat may instead be recovered by carefully matching hot and cold process streams within each site, as described in Section 3. To do so, the processing areas were grouped into three aggregated sites, designated as (I) A200-A300; (II) A400; and (III) A500-A600. Areas A200-A300 were included within site I since they are typically close in a soybean processing facility, given that hexane is recycled from the miscella distillation area to the extraction area. Areas A500 and A600 are in site III because a large portion of the methanolic solution of NaOCH<sub>3</sub> leaving A500 is directed to the transesterification reactors, while the methanol recycling in the biodiesel production may pass through distillation columns in A500.

Table 1 describes the performance summary of the HEN obtained through the application of the optimal design methodology described above. For reference, Table 1 also compares these results with the Original HEN reference design, and the Integrated HEN reported in Granjo et al. (2017). The Original HEN is notoriously inefficient, since both its utility consumption and the total cost are approximately 30 % above the targets. The previous Integrated HEN solution considered the methanol recycling from A600 to A500, and the match between the biodiesel stream with the hexane recycling stream in A300, after heating the glycerol in the purification step. The hexane/water vapours of the evaporation section of A300 were used to heat the miscella stream and the mineral oil in the absorption/stripping unit. Furthermore, the crude soy oil stream leaving A300 provided heat to the aqueous solutions in A400, while the refined soy oil stream leaving A400 provided heat to the methanol make-up stream in A500. The Integrated HEN shows good performance, with a total cost index and utility consumption around 12 % up to 15 % above the targets, while the total heat transfer area is 5,843 m<sup>2</sup> (75 % of target), and requires 52 heat exchanger units. However, this design can be difficult to be implemented in practice, since it has several inter-site stream matchings.

A significantly different HEN structure was obtained in this study. Hot and cold utility consumptions are now close to the energy targets for the current biorefinery configuration, and a lower heat exchange area (5,547 m<sup>2</sup>) is required. However, a larger number of heat exchanger units (73) compared with the Integrated HEN is necessary. This new design shows a similar performance in terms of total cost index as the one previously obtained (13 % above the target), but can be considered preferable, since it avoids inter-site hot / cold stream matching, and leads to a simpler design for practical implementation. The new HEN of site III (A500-A600) represented in Figure 2 is shown in Figure 5.

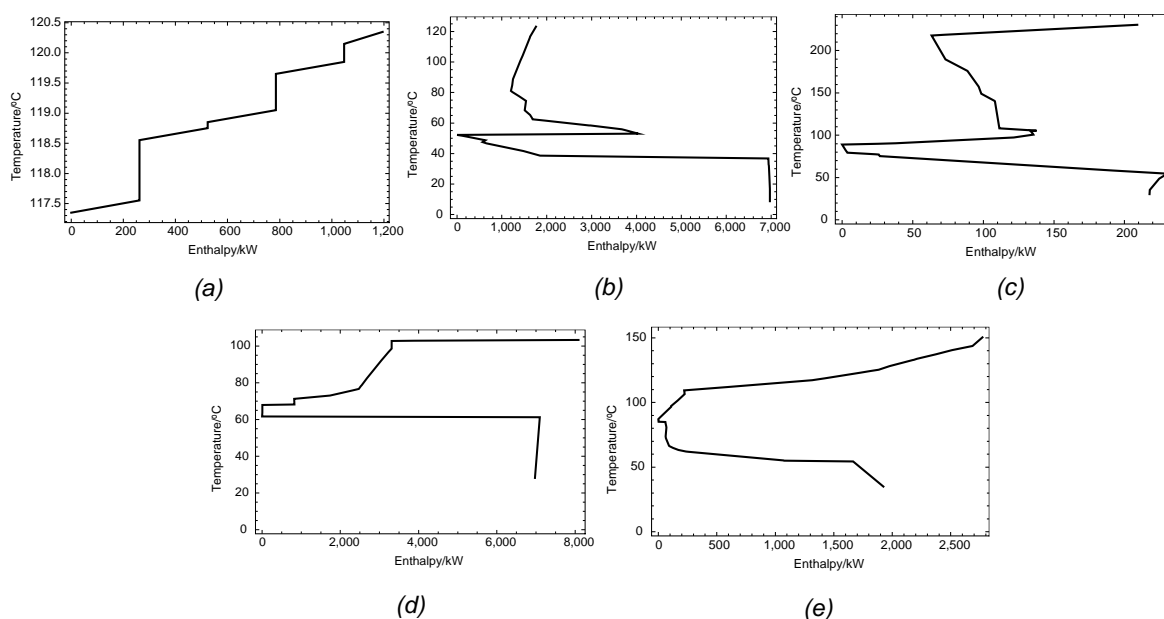

Figure 3: Grand Composite Curves of (a) A200; (b) A300 (c) A400 (d) A500; and (e) A600.

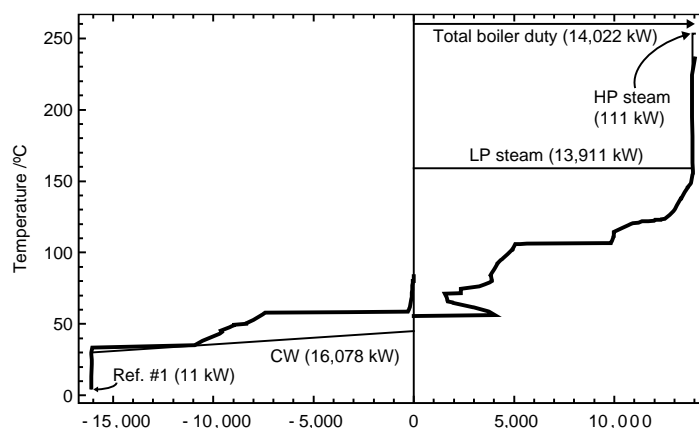

Figure 4: Total Site Profiles with hot and cold utility levels.

Table 1: Targeting results and performances of the original reference design, integrated and the new HEN.

	Original HEN		Integrated HEN		New HEN
	Target <sup>a,b</sup>	Indicator (% target)	Target <sup>a,c</sup>	Indicator (% target)	Indicator (% target)
Heating (GJ/h)	49.12	64.67 (132)	44.18	51.02 (115)	48.71 (110)
Cooling (GJ/h)	56.91	72.45 (127)	51.42	58.26 (113)	55.95 (109)
Number of units	76	53 (70)	88	52 (59)	73 (83)
Total Area (m <sup>2</sup> )	8,002	4,774 (60)	7,784	5,843 (75)	5,547 (71)
Total Cost (\$/s)	0.2171	0.2807 (129)	0.2015	0.2266 (112)	0.2267 (113)

<sup>a</sup>Results are for  $T_{min} = 6.5$  °C, a maximum energy recovery HEN and for the <sup>b</sup> original and <sup>c</sup> integrated biorefinery configuration.

The design of the integrated water network for A100-A600 is relatively simple, since fresh water is only consumed in the bleaching of A400 and in the biodiesel washing stage of A600. Also, the main wastewater streams of the process area in the hexane/water decantation unit of A300 (with approximately 20 ppm of hexane) and the bottom stream of methanol/water distillation column of A500 (with less than 0.1 wt % of methanol). An obvious design is to redirect part of the wastewater generated in A500 to the washing stage in A600 (stream 509 in Figure 2) and part of the wastewater stream leaving the hexane/decanter unit to the bleaching stage.

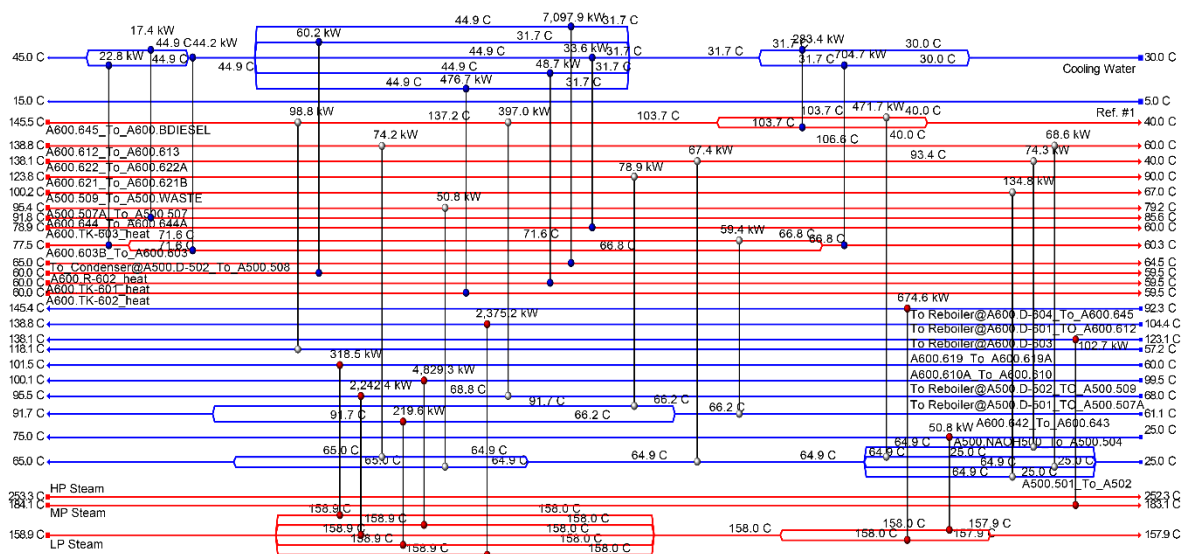

Figure 5: Heat exchangers network in site III (A500-A600).

This configuration obviates the need for fresh water in the process, leaving no additional contaminants in the aqueous effluent streams of A400 and A600, and the wastewater flowrate is reduced by 9 %, relatively to the reference scenario.

## 5. Conclusions

This paper addressed the optimal HEN design of a soybean biorefinery plant, including the beans preparation, solvent extraction and oil refining processing areas, together with the processes to manufacture biodiesel and sodium methoxide. A two-stage methodology was employed; first a Total Site Analysis was carried out to estimate the heat and cooling minimum requirements, and identifying the potential utility co-generation that can be produced and distributed among the sites. In a second stage, the optimal HEN design for each site is performed using the Aspen Energy Analyzer, by minimizing the total cost index.

The results of the TSA show that the temperature levels of the site heat source profile limit the generation and distribution of steam, in the current process configuration. Consequently, the process heat waste is preferably recovered through stream matches within each site. Although the performance of the new HEN design in terms of its total cost index is similar to the one obtained in Granjo et al. (2015), the consumption of utilities and the total heat exchanger area are lower. The higher number of heat exchange units of this new design is offset by the elimination of inter-site stream matches, resulting in a simpler design for practical implementation.

## References

- Aspen Technology, 2010. Aspen energy analyzer: reference guide, version 7.2, Tech. Rep., Burlington, MA.
- Erickson, D.R. (Ed), 1995, Practical handbook of soybean processing and utilization, AOCS Press, Champaign, IL, 592 ps. ISBN: 978-093531563-9.
- Granjo, J., Duarte, B., Oliveira, N., 2015, Soybean Biorefinery: Process Simulation and Analysis, Chemical Engineering Transactions, 45, 583-588, DOI:10.3303/CET1545098.
- Granjo, J.F.O., Duarte, B.P.M., Oliveira, N.M.C., 2017, Integrated production of biodiesel in a soybean biorefinery: Modeling, simulation and economical assessment, Energy, 129, 273-291.
- Klemeš J.J. (Ed), 2013. Handbook of Process Integration (PI): Minimisation of Energy and Water Use, Waste and Emissions, Woodhead/Elsevier, Cambridge, UK, 1184 ps. ISBN: 978-0-85709-593-0.
- Yee, T.F., Grossmann, I.E., Kravanja, Z., 1990, Simultaneous optimization models for heat integration – I. Area and energy targeting and modeling of multi-stream exchangers, Computers & chemical engineering 14(10), 1151-1164.