

Mathematical Model of Heavy Duty Welded Plate Heat Exchanger and its Validation in Industry

Leonid L.Tovazhnyansky^a, Petro O.Kapustenko^{a,*}, Olexandr Y.Perevertaylenko^a, Olga P.Arsenyeva^{*a}, Pavlo Y.Arsenyev^b, Alisher E.Khusanov^c

^aNational Technical University "Kharkiv Polytechnical Institute", Dep. ITPA, 21 Frunze st., Kharkiv, 61002, Ukraine

^bAO SPIVDRUZHNIIST-T LLC, Krasnoznamenny per. 2, off. 19, 61002, Kharkiv, Ukraine

^cM.Auezov South Kazakhstan State University, Tauke hana Avenue, 160012 Shymkent, Kazakhstan
 kap@kpi.kharkov.ua

Plate Heat Exchanger (PHE) is one of the modern types of compact heat transfer equipment, which can significantly enhance the heat recuperation and improve efficiency of energy usage in many industrial applications. The construction of welded PHE (WPHE) is significantly widening the range of its application on temperature and pressure. The construction of investigated WPHE is developed for work in high pressure shell of ammonia synthesis column at pressure up to 32 MPa and temperature up to 520 °C. It consists of the stack of round corrugated plates with diameter 626 mm, which are welded together to form a number of channels for cold and hot streams exchanging heat. The welded collectors of special design are organizing multi pass movement of both streams with overall counter flow. The movement of two streams in one pass block is cross flow with overall counter flow in a whole WPHE. The mathematical model of considered WPHE is developed, which enables to perform the thermal and hydraulic design for specified process conditions and also rating calculations of WPHE with determined parameters of its construction. The validity of the proposed Equations and developed mathematical model is confirmed by comparison with the data of tests on WPHE installed in ammonia synthesis column at industrial enterprise of ammonia production. WPHE was operating in existing synthesis column of ammonia unit instead shell-and-tube heat exchanger. The construction of WPHE and the results of the tests are discussed. The use of WPHE instead shell-and-tube unit enable to cut down the volume occupied by heat exchanger in high pressure shell of ammonia synthesis column and allows increase of the volume of catalyst. It leads to 15 % rise of ammonia output.

1. Introduction

Efficient heat recuperation is of primary importance in resolving the problem of efficient energy usage and consequent reduction of fuel consumption and greenhouse gas emissions, as is discussed by Klemeš at al. (2013). Heat transfer enhancement is substantially facilitates the solution of the problem (Gough et al., 2013). Plate Heat Exchanger (PHE) is one of the modern efficient types of compact intensified heat transfer equipment. The principles of the construction and design for different types of PHEs are sufficiently well described in the literature, e.g. Klemeš et al. (2015). The conventional type is plate-and-frame PHE, which was initially developed for the food industry and later proved efficient in many other applications. It is confirmed by a number of researchers, as e.g. Hajabdollahi et al. (2016) have found in their study case of water to water HE that the comparison of the optimum results for plate-and-frame PHE shown 13 % improvement in the total cost compared with shell-and-tube heat exchanger at the same operating conditions. Their flexibility allows finding economically viable solutions in different processes of waste heat utilisation, as shown by e.g. Arsenyeva et al. (2016). However due to elastomer gaskets the range of plate-and-frame PHE application is limited to pressures up to 25 bar and temperatures up to 180 °C and working fluids friendly to gaskets material. Besides, the cost of the gaskets, especially for severe working conditions, can dramatically increase the cost of heat exchanger as a whole unit. To widen the PHE application range by excluding elastomer gaskets the brazed (BPHE) and welded (WPHE) types of PHE were developed. In the construction

of welded PHE the gaskets between plates are eliminated, that allows to widen significantly the range of its application on temperatures and pressures.

Nowadays there is a number of different by construction principles types of welded PHEs produced by contemporary PHE manufacturers. The comparison of two most widely used types, which are Plate-and-Block (Compabloc) HE and Plate-and-Shell HE (PSHE), is presented by Arsenyeva et al. (2016). According to analysis published by Andersson et al. (2009) before the year 2009 it was installed more than 750 Compabloc HEs only in oil refining industry on different positions worldwide.

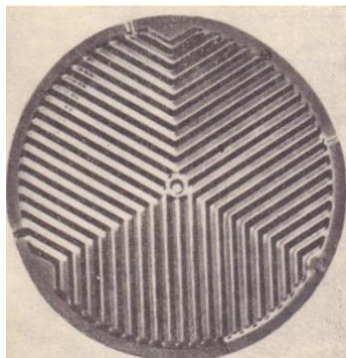

Figure 1: The plate of WPHE for ammonia synthesis column.

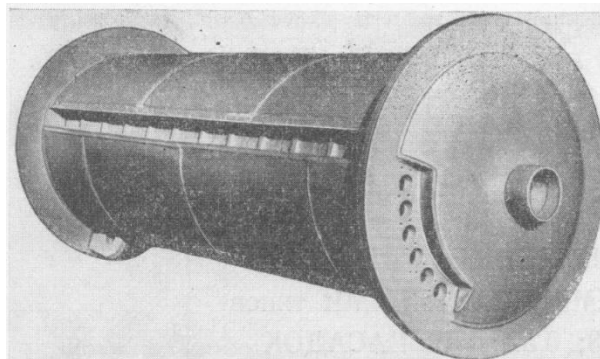

Figure 2: Manufactured WPHE ready for installation

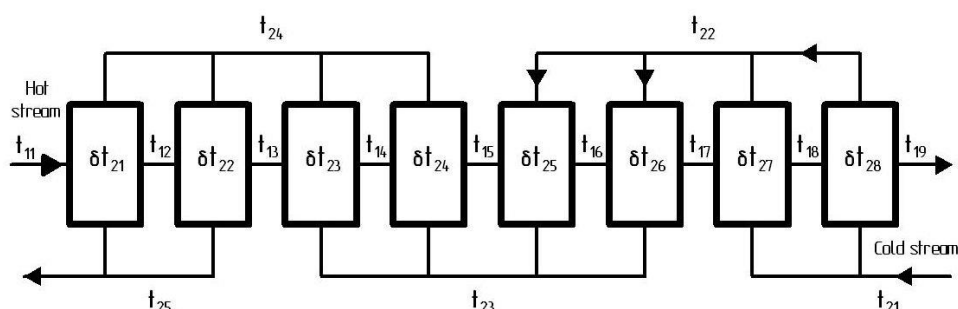

Figure 3: The schematic flow of streams in WPHE

A different design of welded PHE is developed for work at ammonia synthesis process under high temperature up to 520 °C and pressure up to 32 MPa. The WPHE is developed for work in high pressure shell of ammonia synthesis column and consist of a stack of round plates with special form of corrugations, depicted in Figure 1. The plates are welded together in round block of pates (Figure 2) to form a number of channels for cold and hot streams exchanging heat. The welded collectors of special design are organizing multi pass movement of both streams with overall counter current flow. The movement of two streams in one pass block is cross flow. Compare to the flow of streams in conventional plate-and-frame PHE there is significant difference. From hydraulic point of view the stream is entering the channel through almost full cross section, while in channels of plate-and-frame PHE it is entering from distribution collector of small diameter compare to channel width. It causes much smaller local hydraulic resistance at the port zone of WPHE and ensures even flow distribution across channel width. But cross flow of streams causes the reduction of mean temperature difference compare to counter flow in one pass of plate-and-frame PHE. The overall counter flow in WPHE is making this loss in mean temperature difference smaller, but still this cross flow feature for individual passes must be accounted in correct WPHE design.

2. Mathematical model of WPHE

The WPHE for ammonia synthesis column is depicted in Figure 2. The geometrical forms of the channels for hot and cold fluids are different. For the cold stream the channel is formed by one plate with most of the corrugations (at 2/3 plate area) directed along the main flow direction. The adjacent plate has herringbone corrugation direction with angle 60 ° to main flow direction. Resulting average corrugation angle in this area is 30 °. At the remaining 1/3 of plate area the angle of corrugations to flow direction is 60 ° on both adjacent

plates. The average angle of corrugations to flow direction is $\beta_1 = 40^\circ$. Such form of corrugations is made to facilitate the discharge of possible dust in the synthesis gas stream after catalyser, which can appear with catalyser aging. The average angle of corrugations in another channel for hot stream is equal to $\beta_2 = 50^\circ$. The WPHE has 8 passes for hot synthesis gas (channels with $\beta_1 = 40^\circ$) and 4 passes for cold gas. It is schematically shown in Figure 3. The Equations for calculation of heat transfer and pressure drop in one pass of WPHE with such channels were reported by Tovazhnyansky et al. (2016).

The overall heat transfer performance of WPHE is considerably determined by flows arrangement between groups of channels corresponding to passes of heat exchanging streams. In general case of any passes arrangement the WPHE effectiveness can be found by solution of the system of algebraic Equations as presented by Arsenyeva et al. (2015), with assumptions of equal conditions for all channels in one pass and mixing of fluids between passes. The specific case shown in Figure 3 can be considered as heat exchanger with four equal passes with overall counter current flow. According to Kays and London (1984) the total effectiveness ε_T of such heat exchanger can be calculated as follows:

$$\varepsilon_T = - \left[\left(\frac{1 - \varepsilon_x \cdot R}{1 - \varepsilon_x} \right)^4 - 1 \right] \cdot \left[\left(\frac{1 - \varepsilon_x \cdot R}{1 - \varepsilon_x} \right)^4 - R \right]^{-1} \quad (1)$$

Here $R = G_1 \cdot c_{p1} / (G_2 \cdot c_{p2})$ is the ratio of heat capacities for hot and cold streams in WPHE; c_{p1} and c_{p2} are specific heat capacities of hot and cold stream, J/(kg·°C); G_1 and G_2 are mass flow rates of hot and cold stream, kg/s; ε_x is the effectiveness of one pass considered.

One pass (see Figure 3) consist of two blocks of plates arranged for one pass of cold stream and two sub-passes of hot stream. Considering one of these passes, for first pass from the left in Figure 3 the following Equations can be written for temperature change of hot stream in first δt_{11} and second δt_{12} sub-passes:

$$\delta t_{11} = \Delta \cdot \varepsilon_0 \cdot R_0 \quad (2)$$

$$\delta t_{12} = (\Delta - \delta t_{11}) \cdot \varepsilon_0 \cdot R_0 \quad (3)$$

Here $\Delta = t_{11} - t_{24}$ is the temperature difference of streams at the inlet of considered pass; $R_0 = 0.5 \cdot R$ is the ratio of heat capacities for hot and cold streams in sub-passes; ε_0 is effectiveness of the block of plates corresponding to one sub-pass or in our case 1/8 of the total number of plates.

The effectiveness of one pass consisting of two sub-passes:

$$\varepsilon_x = \frac{t_{25} - t_{24}}{\Delta} = \frac{\delta t_{11} + \delta t_{12}}{R \cdot \Delta} = \varepsilon_0 - \varepsilon_0^2 \cdot \frac{R}{4} \quad (4)$$

As it is shown in experiments by Tovazhnyansky et al. (2016) with a model of one sub-pass, the equation for cross flow with stream in channels of lower corrugation angle $\beta_1 = 40^\circ$ unmixed and stream in channels with higher corrugation angle $\beta_2 = 50^\circ$ mixed can be used:

$$\varepsilon_0 = 1 - \exp \left[\frac{-1 + \exp(-R_0 \cdot NTU_0)}{R_0} \right] \quad (5)$$

The number of heat transfer units in one sub-pass $NTU_0 = NTU/8$ is determined in assumption of its equal distribution in all heat exchanger. The total number of heat transfer units in WPHE:

$$NTU = \frac{F_a \cdot U}{G_2 \cdot c_{p2}} \quad (6)$$

The overall heat transfer coefficient U is calculated for average physical properties of fluids using correlations for film heat transfer coefficients h_1 and h_2 presented by Tovazhnyansky et al. (2016).

$$U = \left(\frac{1}{h_1} + \frac{1}{h_2} + \frac{\delta_w}{\lambda_w} \right)^{-1} \quad (7)$$

where δ_w is the thickness of plate wall, m; λ_w is the heat conductivity of plate metal.

For calculation of the pressure losses the division of the channel on main corrugation field and distribution zones at the inlet and outlet of the inter-plate channel is used. Arsenyeva et al. (2013) introduced the coefficient of local hydraulic resistance in those zones ζ_{Dzi} , with which the pressure drops in can be calculated by Equation, Pa:

$$\Delta p_i = \left(\zeta_i \cdot \frac{L}{d_e} \cdot \frac{\rho_i \cdot w_i^2}{2} + \zeta_{Dzi} \cdot \frac{\rho_i \cdot w_{enx,i}^2}{2} \right) \cdot X_i \quad (10)$$

where $w_{enx,i}$ is the velocity at channel entrance/exit; w_i is velocity in channels, m/s; ρ_i is fluid density; ζ_i is friction factor in channel, calculated by Equation proposed by Arsenyeva et al. (2012). The coefficients of local hydraulic resistance in distribution zones $\zeta_{Dz1}=11$ and $\zeta_{Dz2}=17$.

The presented Eqs. (1)-(10), with correlations proposed based on experiments with the model of one pass WPHE by Tovazhnyanskyy et al. (2016), enable to calculate thermal performance of considered WPHE. The validity of this mathematical model is checked based on data obtained for WPHE installed in ammonia synthesis column, as is described in the next section.

3. Results of WPHE tests in the industry

The tested WPHE was installed in ammonia synthesis column working at ammonia production plant.

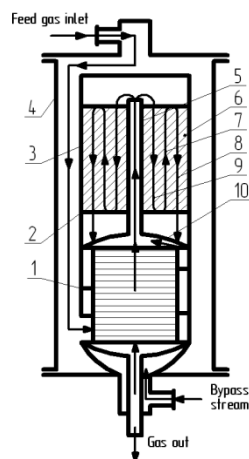

Figure 4: The schematic flow of streams in ammonia synthesis column. 1 - WPHE

The construction of the column is shown in Figure 4. The WPHE (1) and reactor catalyzer box (3) are incased in high pressure shell (4) of 800 mm internal diameter, designed for working pressure 32 MPa and temperature 520 °C. The feed gas is supplied from the top of the column and going down through the annular space between the shell and incased equipment to the inlet of WPHE with temperature t_{21} . There it is heated to high temperature t_{25} by the gas coming after reactor. After WPHE gas is mixing with the stream of bypass gas of temperature t_{b2} . Bypass gas is supplied from the bottom of the column with temperature t_{b1} and coming to mixing area through two special pipes at the sides of WPHE. After mixing the gas is directed to the central pipe (5) from which to the upper space of the catalyzer box (3) and to field tubes, internal (9) and external (7), where it is heated and after going to direct contact with catalyzer (8). After catalyzer zone (6) and header (2) gas with temperature t_{11} is directed to the WPHE where it is cooled down to temperature t_{19} and leaving column from the bottom.

The temperatures at the inlets and outlets of heat exchanger were measured by chromel–alumel thermocouples which were entering the column through high pressure nozzle of special design. The flow rates of feed gas and bypass gas were measured by calibrated orifice flow meters. The pressures of the feed gas and outgoing gas were measured with high pressure gauges.

The main geometrical parameters of the tested WPHE, plate corrugations and inter-plate channels are presented in Table 1. The results of the three tests (with no bypass stream) and calculations of WPHE heat transfer performance are presented in Table 2. The physical properties of hydrogen-nitrogen mixture with ammonia are taken according to Melnikov (1986).

The experimental value of heat transfer effectiveness is calculated by Eq(11)

$$\varepsilon_{TE} = \frac{t_{25} - t_{21}}{t_{11} - t_{21}} \quad (11)$$

It is in good agreement with WPHE effectiveness ε_T calculated by Eqs. presented in Section 2 of this paper. It confirms the accuracy of proposed mathematical model and validity of it for design of WPHEs of the type considered here.

Table 1: Parameters of tested WPHE

Total heat transfer surface area, F_a , m ²	114.2	Heat conductivity of the wall, λ_w , W/(m K)	16
Number of plates, N_p	359	Corrugations height, b , m	0.004
Heat transfer surface area of one plate, F_p , m ²	0.32	Corrugations pitch, S , m	0.018
Height of WPHE, m	1.82	Average channel width, W_{ch} , m	0.55
Cross section area of one channel, f_{ch} , m ²	0.0022	Equivalent diameter of channel, d_e , m	0.008
Plate outside diameter, D_o , m	0.626	For hot stream, β_1 , degrees	40
Plate thickness, δ_w , m	0.001	For cold stream, β_2 , degrees	50
Plate metal	AISI 304	The width of channel entrance (exit), W_{enx} , m	0.4

Table 2: The results of WPHE tests in industry

	Test #1	Test #2	Test #3
Gas flow rate, kg/s	5.55	5.54	4.39
Temperature of hot gas inlet t_{11} , °C	496	495	487
Temperature of hot gas outlet t_{19} , °C	190	198	195
Temperature of cold gas inlet t_{21} , °C	78	75	82
Temperature of cold gas outlet t_{25} , °C	373	380	389
Pressure at column entrance P_{in} , MPa	30	29	30
Pressure at column exit P_{out} , MPa	28.5	27.5	28.5
Ammonia concentration in cold feed gas, %mol	3.3	3.3	3.3
Ammonia concentration in hot gas, %mol	17.2	17.2	17.2
Calculated temperature of cold gas outlet t_{25calc} , °C	382.5	380.9	381.2
Calculated overall heat transfer coefficient U , W/(m ² K)	1,146	1,145	970
Number of heat transfer units NTU (calculated)	6.46	6.45	6.91
Heat transfer effectiveness ε_T (calculated)	0.729	0.728	0.739
Heat transfer effectiveness ε_{TE} (experiment)	0.706	0.726	0.758
Discrepancy, %	-3.2	0.32	2.5
Counter current flow heat transfer effectiveness ε_{Tcc}	0.841	0.840	0.847
The loss of effectiveness due to cross flow, %	13.2	13.2	12.8

The WPHE is installed instead of tubular heat exchanger of heat transfer area 148 m² with the length 3,000 mm. WPHE has the weight 1,694 kg instead of 2,992 kg of tubular heat exchanger and occupying volume 0.96 m³ that is less on 0.48 m³. This spare volume is used to increase the amount of catalyser in the column. It leads to 15 % rise of ammonia output.

At the same time the cross flow in one pass of WPHE still remains an important factor jeopardizing its overall heat transfer performance. To estimate this effect the heat transfer effectiveness for pure counter current flow is calculated according to Shah and Sekulić (2003) by Eq(12)

$$\varepsilon_{Tcc} = \frac{1 - \exp[-NTU \cdot (1 - R)]}{1 - R \cdot \exp[-NTU \cdot (1 - R)]} \quad (12)$$

The comparison of total heat transfer effectiveness ε_T with its value for pure counter current flow shows the reduction about 13 %. The analysis of Eq(4) indicates that some reduction of heat transfer effectiveness in one pass is caused by existence of two sub-passes with not symmetrical flow arrangement (2 sub-passes for hot stream – 1 pass for cold stream). It leads to conclusion of advantage of symmetric flow arrangement with equal passes numbers for both streams even with cross flow in separate channels. However due to technological or other reasons, like in our case requirement to remove catalyser dust coming with hot gas, it is important to have not equal passes numbers. In that case, the optimisation of passes arrangement is required

with the use of more general Equations presented by Arsenyeva et al. (2015) and correlations for heat transfer in one pass flow which validity are in present study.

4. Conclusions

The mathematical model of WPHE for ammonia synthesis column is presented. It accounts for the main factors influencing the WPHE heat transfer performance: the heat transfer in channels for streams flow, crossflow in individual channels exchanging heat, and complex passes arrangement with overall counter current flow. By validating model in industrial conditions it is confirmed:

- The accuracy for cross flow in PHE channels with different corrugations geometry of the correlations proposed for heat transfer coefficients.
- The validity of the Equation for heat transfer effectiveness in one pass with cross flow obtained with assumption of one stream mixed another unmixed.
- These Equations can be used for calculation of WPHE with cross flow inside separate passes.

The industrial tests have confirmed the advantages of WPHE installed in ammonia synthesis column compare to traditional tubular heat exchanger. The use of WPHE instead tubular heat exchanger enable to cut down the volume occupied by heat exchanger in high pressure shell of ammonia synthesis column and allows increase of the volume of catalyst. It leads to 15 % rise of ammonia output. The reliability and good performance of WPHE is confirmed by three years of operation in such heavy temperature and pressure conditions as up to 520 °C and 32 MPa.

Acknowledgments

The support of Grant of Education and Science Ministry of the Republic Kazakhstan in state program “Grant funding for research”, for sub priority:” Power and machine building (Heat and power generation and energy-efficient technologies)” is sincerely acknowledged. Olga Arsenyeva is grateful to the Alexander von Humboldt Foundation for the financial support.

References

- Andersson E., Quah J., Polley G. T., 2009, Experience in Application of Compabloc Heat Exchangers in Refinery Pre-Heat Trains. In: Muller-steinhausen, H., Malayeri, M. R., Watkinson, A. P., eds. Proceedings of the International Conference on Heat Exchanger Fouling and Cleaning VIII-2009, Schladming, Austria. 39-43.
- Arsenyeva O. P., Čuček L., Tovazhnyanskyy L. L., Kapustenko P. O., Savchenko Y. A., Kusakov S. K., Matsegora O. I., 2016, Utilisation of waste heat from exhaust gases of drying process. *Frontiers of Chemical Science and Engineering*, 10 (1), 131-138.
- Arsenyeva O.P., Tovazhnyanskyy L.L., Kapustenko P.O., Demirskiy O.V., 2012, Heat transfer and friction factor in criss-cross flow channels of plate-and-frame heat exchangers, *Theoretical Foundations of Chemical Engineering*, 46 (6), 634-641.
- Arsenyeva O., Kapustenko P., Tovazhnyanskyy L., Khavin G., 2013, The influence of plate corrugations geometry on plate heat exchanger performance in specified process conditions. *Energy*, 57, 201-207.
- Arsenyeva O.P., Tovazhnyanskyy L.L., Kapustenko P.O., Khavin G.L., Yuzbashyan A.P., Arsenyev P.Y., 2015, Two Types of Welded Plate Heat Exchangers for Efficient Heat Recovery in Industry, *Applied Thermal Engineering*, 105, 763-773.
- Gough M., Farrokhpahan S., Bulatov I., 2013, Retrofit process heat transfer enhancement to upgrade performance, throughput and reduced energy use. *Clean Technol. and Environm. Policy*, 15(3), 423-431.
- Hajabdollahi H., Naderi M., Adimi S., 2016, A comparative study on the shell and tube and gasket-plate heat exchangers: The economic viewpoint. *Applied Thermal Engineering*, 92, 271-282.
- Kays, W.M., London, A.L., 1984, *Compact Heat Exchangers*. McGraw-Hill, New York, NY, USA.
- Klemeš J. J., Varbanov P. S., Kapustenko, P. (2013). New developments in heat integration and intensification, including total site, waste-to-energy, supply chains and fundamental concepts. *Applied Thermal Engineering*, 61, 1–6.
- Klemeš J.J., Arsenyeva O., Kapustenko P., Tovazhnyanskyy L., 2015, *Compact Heat Exchangers for Energy Transfer Intensification: Low Grade Heat and Fouling Mitigation*. CRC Press. Boca Raton, FL, USA.
- Melnikov E.Y.(ed.), 1986, *Guide of Ammonia Producer*. Book 1. Himiya, Moscow, USSR (in Russian)
- Shah R. K., Sekulić D. P., 2003, *Fundamentals of heat exchanger design*. John Wiley & Sons. NJ, USA.
- Tovazhnyanskyy L. L., Kapustenko P. O., Perevertaylenko O. Y., Khavin G. L., Arsenyeva O. P., Arsenyev P. Y., 2016, Heat transfer and pressure drop in cross-flow welded plate heat exchanger for ammonia synthesis column, *Chemical Engineering Transactions*, 52, 553-558.