

Risk Assessment for Process Accident Prevention Using Screening Questionnaire

Yukiyasu Shimada^{a,*}, Yoshihiko Sato^a, Haruhiko Itagaki^a, Tetsuo Fuchino^b

^a National Institute of Occupational Safety and Health, Japan, 1-4-6, Umezono, Kiyose, Tokyo Japan

^b Tokyo Institute of Technology, 2-12-1, Oookayama, Meguro, Japan

shimada@s.jniosh.johas.go.jp

Risk assessment methods are based on the development of hazard scenarios, which requires identification of latent hazards in process industry, including chemical substance/process, equipment and operation, as well as events that can lead to process hazards. This is quite difficult without acquiring adequate knowledge and experience about process plant design, related operations, and/or resources to perform risk assessment internally. This paper proposes a systematic and iterative framework of risk assessment based on screening questionnaires regarding properties of chemical substances and handling processes (chemical and process hazard). With the use of screening questionnaires, chemical and process hazard perception can increase the motivation of conducting risk assessment for process hazards. The answers to these questionnaires provide the required information for better risk-informed decisions and will support the prevention of process accidents. A selected case study is used to show the effectiveness of the proposed framework.

1. Introduction

Key success factors to perform proper risk assessment include proper recognition of chemicals and adequate specification of potential hazards that might cause process accidents. The identification of realistic and possible hazard scenarios is also essential to achieve proper risk assessment. Most of SMEs (small and medium enterprises) of chemical process industries have minimum awareness of process risks and have less recognition of the needs for conducting risk assessment, where they believe that the use of small quantities of handling chemical substances does not lead to dangerous conditions and they will have little chance to experience severe process hazards. Therefore, it is required that some support tools are proposed to help SMEs with understanding the importance of performing risk assessment for process accident prevention. It should be easy-to-use and offer as much of reference information or materials and case examples of process accidents as possible.

Conventionally, various approaches to identify chemical reactivity hazard have been proposed. The CCPS preliminary screening method for chemical reactivity hazards is based on a series of twelve "Yes/No" questions and is a tool to help users identify where chemical reactivity hazards are likely to occur in their facility (Johnson R.W., 2003, EPA, 2004). It may be applicable to a wide range of activities including warehousing, repackaging, blending, mixing, and processing. Chemical reactivity evaluation tool and Help Guides that accompanies it can be used as an aid in identifying and evaluating chemical reactivity hazards so that they may be effectively avoided or controlled (Davis E.M. et al., 2012a & 2012b). This tool is designed to complement the user's understanding of known reactivity hazards. The protocol in this computer program is targeted to identify only 80% of the 167 serious incidents listed by the United States Chemical Safety Board (CBS, 2002). The Help Guide is prepared to assist the user in becoming proficient in the use of the reactivity evaluation software tool. There is no guarantee that all reactivity hazards will be identified. HarsMeth (Hazard Assessment of highly Reactive Systems: A Methodology) is a guide for the safety assessment of chemical processes (HarsMeth NP, Nomen R. et al., 2008). This is intended to identify the possible hazards that may be encountered during the performance of a chemical process. It consists on a set of checklists that cover all the steps involved in industrial production. Besides, it provides guidance on available techniques for the determination of safety parameters of chemical reactions, and available measures in order to reduce

probability and severity of an accident in process plant. In addition, many other checklists or flowsheets have been proposed for comprehensive company risk management and occupational health and safety management system. Commonly, these tools are intended to help SMEs with the safety analysis of their chemical processes.

This paper focuses on risk assessment of chemical plant process and proposes a systematic and iterative framework of risk assessment based on screening questionnaires regarding properties of chemical substances and handling processes (chemical and process hazard). This is also intended to help SMEs with highlighting possible hazards and critical elements of the process to the user's attention.

2. Outline of Iterative Process of Risk Assessment

Figure 1 shows a proposed iterative process of risk assessment. It specifies logical thinking approach to promote the effective performance of risk assessment as per the following three steps at process and plant design stage.

STEP-1: Grasp hazards involved in the substances handled and the process by answering screening questionnaires on their characteristics, while confirming possible process accidents and enhance the consciousness of possible risks and process accidents.

STEP-2: Perform risk assessment for a hazard scenario by referring to the result of STEP-1.

STEP-3: Compile the results of STEP-2 for a set of hazard scenarios and decide what risk reduction measures should be implemented depending on the technical and cost factors, etc.

The proposed framework can recognize the possibility of process accidents and the logical grounds for the implementation of risk reduction measures, which are specified in the RA record sheets, and implement effective safety management activities.

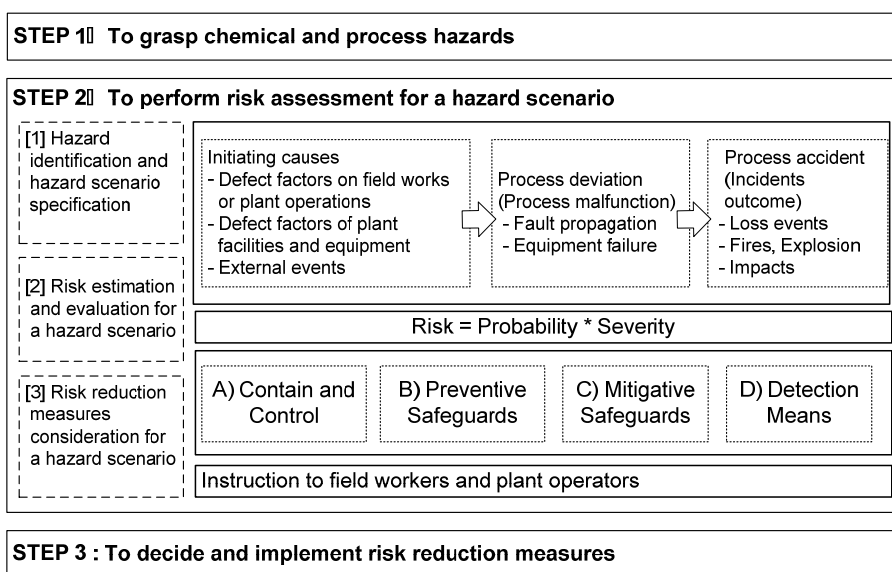

Figure 1: Iterative risk assessment process

2.1 STEP-1: Grasp chemical and process hazards by answering screening questionnaires

This paper proposes questionnaire sheet to confirm the property of the objective chemical substance and the processing process, and the process hazards associated with the occurrence of process accidents as shown in Table 1. These questions have been selected with reference to CCPS Guidelines etc. (AIChE/CCPS, 2000, Johnson R.W., 2003). There are 9 questions to confirm hazard property of substance handled, 5 questions to confirm hazard of reaction process such as mixing, physical processing, etc., and 3 questions to confirm effect by external events. Intent of Q1 is to check whether the objective chemical substance is target on the legal requirement and the latest act amendment in Japan. Intent of Q2 is to confirm GHS (Globally Harmonized System) information. For other questions Q3-Q17, the intents of question [Description] and the examples of related process accidents [Accident Case Example] are provided as shown in Table 2 (only Q1-Q3 due to limitations of space). Basically, it is assumed that Q3-Q9 can be answered by confirming SDS information on the chemical substance, Q10-Q14 by checking the process flow, and Q15-Q17 by investigating external

conditions. It is also desirable to use accident case databases and other sources to investigate hazards of process accident occurrence at plant processes that are using similar substances or processes.

To answer these questions helps with identifying the possible process hazards and performing risk assessment at the STEP-2.

- Answer "Yes" means that there are some kinds or another potential hazard for the chemical substances and/or processes. Risk assessment should be performed to analyze them in detail at STEP-2.
- Even if all the questions are answered as "No", it is desirable to perform risk assessment because their defects/malfunction in works/operations or equipment/devices may arise.
- If it is not sure whether the question is applicable or not, deem that it is applicable (answer "Yes") and carry out detailed analysis when performing risk assessment at STEP-2.

It is advised to conduct literature research, discussion with employees, consultation with experts, experiments to evaluate physical hazards and other methods for detailed analysis. Response to this questionnaire also makes field workers and plant operators aware of the possible risk of occurring process accident.

Table 1: Questionnaire sheet for grasping hazards involved in the substances handled and the process

No.	Question	Yes / No
Q1	Is investigation of danger or harm (Risk Assessment) mandatory for the substance handled?	Yes / No
Q2	Is the GHS classification of the substance other than "Not applicable", "Not classified" or "TYPE G"?	Yes / No
Q3	Is the substance combustible or flammable?	Yes / No
Q4	Does the substance have chemical groups related to explosive or self-reactive property?	Yes / No
Q5	Is the substance combustible powder (combustible dust) (e.g. organic, metal)?	Yes / No
Q6	Does the substance generate peroxides?	Yes / No
Q7	Does the substance polymerize?	Yes / No
Q8	Is the substance liquefied gas?	Yes / No
Q9	Is the substance suspected to have danger or harm despite the absence of SDS?	Yes / No
Q10	Are reactions (including side/ competition reactions) performed intentionally in the process?	Yes / No
Q11	Does temperature increase during some physical operation in the process?	Yes / No
Q12	Are there possibilities of any of the followings due to intended or unintended mixing of substances in the process? (1) Increase in temperature (2) Generation of substances that have the hazards of GHS classification (see Question 2) (3) Generation of large quantities of gas (4) Decreased thermal stability of the substance handled	Yes / No
Q13	Does the process have parts that are not at ordinary temperatures and pressures (high/low temperature, high pressure, vacuum (low pressure), repeated temperature/pressure increase/decrease)?	Yes / No
Q14	Does the process plant have a large quantity of substances?	Yes / No
Q15	Does the process have parts prone to corrosion?	Yes / No
Q16	Are there external stresses to the process (e.g. external corrosion due to rainwater, material degradation due to ultraviolet ray)?	Yes / No
Q17	Does the process plant have high-voltage/current places?	Yes / No

Table 2: Description and Accident Cases for 17 questions (only Q1-Q3 due to limitations of space)

No.	Description and Accident Cases
Q1	[Description] Many of the notifiable substances have not only toxicity but also explosive/flammable characteristics that are hazards leading to a process accident. For physical and health/environmental hazards, see <i>GHS classification included in SDS of the substance</i> .
Q2	[Description] GHS classification is listed in "2. Hazards Identification" of SDS. At this stage, "Classification not possible" is deemed as having hazard. For detailed description of each classification, see <i>GHS classification included in SDS of the substance</i> .
Q3	[Description] Some substances (gas, liquid, solid) without SDS that are not products can also cause fire/explosion (e.g. exhaust gas from petroleum refining, organic waste liquid, combustible waste.) Among them flammable gas is very commonly used. For this reason, it is more likely to cause fire/explosions. [Accident Case Examples] 1) In an asphalt plant of a road paving work company, piping that was feeding asphalt raw material to an asphalt storage tank (9.2m high) was clogged. When three mechanics were replacing the piping, the tank exploded, turning the roof outward. One mechanic who was doing oxy-fuel cutting fell to the ground and was killed. It is believed that when a bolt of piping flange was cut using acetylene gas, volatile component of asphalt in the piping was ignited by sparks of cutting. 2) During air blowing test for starting operation after periodic repair in the distillation / desulfurization area of a refinery, a gas explosion occurred suddenly inside a gas duct of the upper part of the combustion furnace. It is presumed that flammable exhaust gas of the flare (e.g. methane, hydrogen, ethylene, ethane) flew into the gas duct due to the leak from a certain valve, was mixed with air and exploded due to some ignition source.

2.2 STEP-2: Perform risk assessment for a hazard scenario

Risk assessment is performed by referring to the result at STEP-1. Table 3 shows a proposed RA implementation sheet that includes case examples explained in Chapter 3.

Table 3: RA implementation sheet

		Day	Sign	
STEP-1: To confirm chemical and process hazards				
Responses to questionnaires	Combustible and flammable nature, combustible powder, high press. rising and reducing press., high voltage and high electrical current			
STEP-2: To perform risk assessment for an initiating hazard				
[1] Purpose of objective work or ope. & equip. and facility	Inert atmosphere in the mixing tank to prevent dust explosion			
[1] Hazard scenario	Initiating hazard (Initial event)	V109 erroneously open		
	Process deviation (malfunction)	Inflow of oxygen to T100 → Insufficient nitrogen substitution → Formation of dust cloud → Ignition of powder due to electrostatic discharge by agitation		
	Process accident (incident outcome)	Dust explosion in tank T100		
[2] Existing risk reduction measures	Mixing in inert atmosphere (B-b)			
[2] 1 st step risk estimation and evaluation; under assumption of no existing risk reduction measures	Severity	Probability	Risk Level	
	x	Δ	III	
[2] 2 nd step risk estimation and evaluation; Confirmation of effectiveness of existing risk reduction measures	Severity	Probability	Risk Level	
	x	Δ	III	
[3] 3 rd step risk estimation and evaluation; Confirmation of effectiveness of additional risk reduction measures	1) Install limit switch to detect on-off condition of V109 (D-b) and interlock system which obtains answer back from the status of the limit switch (A-b)	S	P	RL
	2) Interlock system by high oxygen concentration at agitator start-up (invalidation of blending) (B-b)	x	o	II
	3) Blast diffusing port at T100 (C-b)	x	o	II
[3] Availability of additional risk reduction measure	Proposed risk reduction measures 1) - 3) can reduce risk and do not interfere with existing risk reduction measures.			
[3] Message or instruction to field workers and plant operators	1) Check sensor of limit switch periodically 2) Operating check of interlock monthly 3) Visual check explosion venting monthly			
[3] Residual risk	Possibility of dust explosion. To follow the manual.			
Remark	---			

[1] Hazard identification and hazard scenario specification

Purpose and objective of the field work and the plant operation, and the facility and the equipment are confirmed. A potential hazard other than process behavior is identified from following; 1) defect factor on field works and plant operations (incl. human error), 2) defect factor on plant facilities and equipment, 3) external events. A fault propagation process from the identified initiating hazard to a process accident by way of process deviation (high temp., high press., etc.) is specified as a hazard scenario. Process accidents are considered by referring to past accident case examples at STEP-1 and the other databases.

[2] Risk estimation and evaluation for a hazard scenario

Two step risk estimation should be performed to confirm the effectiveness of existing risk reduction measures. Risk reduction measures to prevent process accident is considered based on application of the concept of multiple protection measures, that is, A) contain and control, B) preventive safeguard, and C) mitigative safeguard (AIChE/CCPS, 2008). To function these risk reduction measures, D) detection means are designed with corresponding risk reduction measure. On the other hands, when determining risk reduction measures, or considering changes to existing risk reduction measures, consideration shall be given to reducing the risks according to following hierarchy type <priority of implementation and higher reliability>, that is, a) inherent safety measure (elimination/substitution), b) engineering control, c) signage/warning and/or administrative control, and d) personal protective equipment (OHSAS18001:2007, 2007, OHSAS 18002:2008, 2008). Purposes A) to D) and types a) to d) are recorded clearly so that field workers and plant operators understand the design rationale of risk reduction measure and share as process safety information.

[3] Consideration of additional risk reduction measures for the hazard scenario

For the hazard scenario with higher risk, additional risk reduction measures are considered to reduce the risk in order based on the concept of multiple protection measures and the priority of implementation and higher

reliability. 3rd step risk estimation is performed under the assumption that the additional risk reduction measures are implemented. This is repeated until the risk is tolerable. It is confirmed whether the additional risk reduction measures can be implemented or not in consideration of interference with usual work, normal operation, implementation of other risk reduction measures, etc. Message or instruction are recorded in the RA implementation sheet to convey to field workers and plant operators as written description.

- Purpose and type of the existing and additional risk reduction measure.
- Field work or plant operation required to maintain the function of risk reduction measure.

In the presence of residual risk, countermeasure required of field workers and plant operators should be studied and written down as the message to field workers and plant operators. They recognize the possibility of the process accident and the logical ground for the implementation of risk reduction measure which are specified in the RA implementation sheets and perform the meaningful safety management activities. Other remarks should be also contained if any.

[4] Repetition [1] – [3]

Identify various initiating hazards and perform risk assessment for scenarios caused by each one.

2.3 STEP-3: Decide and implement risk reduction measures

RA implementation sheets for various hazard scenarios developed at STEP-2 are compiled into a RA result sheet. Risk reduction measures for the process plant are decided in consideration of technical and cost aspects, etc. and implemented.

3. Case Study

Figure 2 shows a P&ID of case study process. The process of having a mixing tank is chosen. The agitator driven by the motor is in the mixing tank. The measurement tank for main raw materials (powders) is upstream of the mixing tank. The main raw material is supplied to the mixing tank by compressed air. An auxiliary material (powders) is supplied by a hand through the manhole of the mixing tank. The nitrogen line for replacement and the compressed air line for cleaning and drying are connected to the mixing tank. Two kinds of powder are set to polyethylene powder and polystyrene powder.

As results of answer to 17 questions for the case study process, the substances handled is exempt from the regulation concerning risk assessment in Japan (by Q1), but it is concerned that there are 4 kinds of potential hazard (by Q3, Q5, Q13, and Q17) as shown in Table 4. It is proposed to perform risk assessment which focuses on these potential hazards at STEP-2.

Risk assessment has been performed based on the result of STEP-1. Table 3 shows RA implementation sheet for a scenario. The target operation is "closing of the airline valve of loading of main material by valve operation". The open of the valve which should be closed has been selected as an initiating hazard. Air flows into the mixing tank by open of the airline valve. The flammable plastics powder exists in the mixing tank (by Q3 and Q5). Static electricity is charged into plastics powder by friction (by Q5). That is, since the conditions of combustion are formed, dust explosion may occur. Confirmation of existing risk reduction measure and risk estimation and evaluation have been performed. 3 kinds of additional risk reduction measure have been proposed and message or instruction for field workers or plant operator have been recorded clearly.

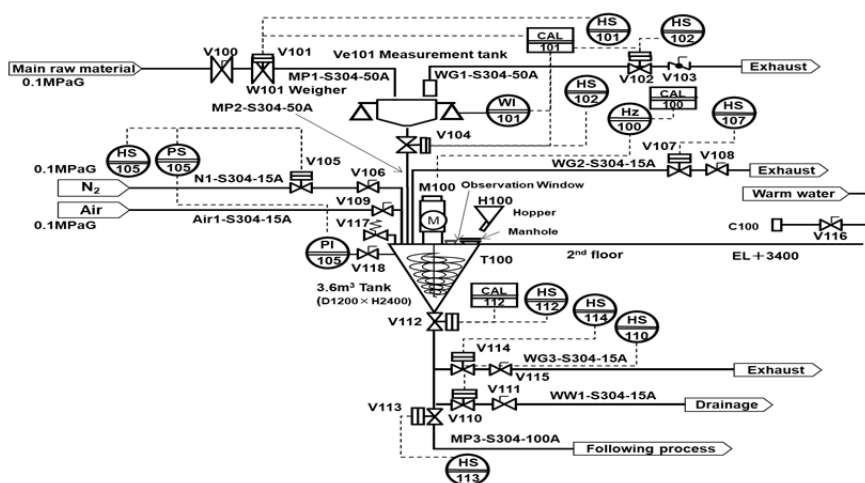

Figure 2: Case example process

Table 4: Answer the Questions (only "Yes" answers due to limitations of space)

[Answer to Q3] Some substances (gas, liquid, solid) without SDS that are not products can also cause fire/explosion (e.g. exhaust gas from petroleum refining, organic waste liquid, combustible waste). Additional literature documents, data, etc. are reviewed. Two raw materials are plastics powder. Plastics powder burns with an easily. Since they burn when flame approaches, answer is "Yes". That is, flammable gas is more likely to cause fire/explosions.
[Answer to Q5] Since both two raw materials are organic powder and combustible, answer is "Yes". That is, combustible dusts may cause explosions when they disperse in the atmosphere and are ignited. They may also fire spontaneously when piled up.
[Answer to Q13] Since main material is transported by compressed air, there is high pressure. Since that is repeated, there is repeated pressure. Answer is "Yes". That is, contents may leak by deterioration of sealed parts. Conversely, if air or other substances enter the process, contents may react.
[Answer to Q17] Since there is an agitator for mixing operation, there is high-voltage / current place. Answer is "Yes". That is, short circuit and earth defects themselves may cause ignition. Joule heat may cause explosion of electric wire.

In addition, various initiating hazards have been identified and risk assessment has been performed for each one by referring to [description] and [accident case examples] of questions Q3, Q5, Q13, and Q17. Since each question includes points to keep in mind for performing risk assessment and related incident case examples, using the result of answer for the questions makes it easy to consider process hazard scenario and risk reduction measures.

4. Conclusions

This paper proposes a systematic and iterative framework for risk assessment based on screening questionnaires regarding properties of chemical substances and handling processes. Potential process hazards in the chemical substances and the plant process are recognized using the proposed questionnaire sheets. The answer to these questions makes it possible to make a short list of potential chemical and process hazards and enhances the awareness of those involved in the risk assessment process applied on handling chemical substances and the associated processes. In addition, it helps SMEs with conducting proper risk assessment. However, since the proposed questionnaire sheet does not cover all the chemicals and process hazards, it is required to perform risk assessment in more detail.

Acknowledgments

The authors are grateful to the following process safety experts for their cooperation in discussion: Prof. Y.Naka (TITech), Dr. H.Saito (Saito MOT Labo.), Mr. H.Sumida (Toyo Engng. Corp.), Mr. K.Bito (Kawasaki Heavy Industry Corp.), Mr. T.Minamigawa (AGC Corp.), Mr. H.Goto (Consultant), and Mr. K.Yamada (JISHA)

References

- AICHe/CCPS, 2000, Guidelines for Chemical Process Quantitative Risk Analysis, 2nd Ed., AICHe/CCPS, New York, USA.
- AICHe/CCPS, 2008, Guidelines for Hazard Evaluation Procedures, 3rd Ed., AICHe/CCPS, New York, USA.
- CSB, 2002, Hazard Investigation, Improving Reactive Hazard Management, 2001-01-H, October 2002.
- Davis E.M., Silva D., Murphy J., 2012a The CCPS Chemical Reactivity Evaluation Tool, Process Safety Program, 31, 203-218.
- Davis E.M., Silva D.E., Murphy D.E., Johnson R.W., Rudy S.W., 2012b, Chemical Reactivity Evaluation Tool Help Guide, AICHe/CCPS/RMR, New York, USA.
- EPA, 2004, Identifying Chemical Reactivity Hazards: Preliminary Screening Method, 550-F-04-004, May 2004, www.epa.gov/ceppo.
- HarsMeth NP, A short cut chemical process safety assessment procedure specially designed for SMEs, Version 3.0 - under Revision -, HarsNet (Thematic Network on Hazard Assessment of Highly Reactive Systems) and IQS (INSTITUT QUIMIC DE SARRIA, Universitat Ramon Llull).
- Johnson R.W., Rudy S.W., Unwin S.D., 2003, Essential Practices for Managing Chemical Reactivity Hazards, AICHe/CCPS, New York, USA.
- Nomen R., Sempere J., Aviles K., Serra E., Sales J., 2008, Development of the HarsMeth methodology for hazard assessment of highly reactive systems: HarsMeth new process, J. of Loss Prevention in the Process Industries, 21, 29-37.
- OHSAS 18001:2007, 2007, Occupational health and safety management systems- Requirements.
- OHSAS 18002:2008, 2008, Occupational health and safety management systems - Guidelines for the implementation of OHSAS 18001:2007.