

Utilizing MOSFET - Based Buck - Boost Converter to Ensure the Operation of New Energy Vehicle Battery System at Low Temperature

Borui Wang^{1,*}

¹ Electronic and Computer Engineering Department, Hong Kong University of Science and Technology, New territory, HKSAR, 999077, China

*Corresponding author's e-mail: bwangbi@connect.ust.hk

Abstract: This article proposes a MOSFET-based buck-boost DC/DC converter solution to the problem of battery output voltage drop in low-temperature environments for electric vehicles. At low temperatures, the chemical reaction rate of the battery slows down, resulting in a drop in output voltage, which cannot provide a stable voltage for the drive system. To solve this problem, it is proposed to add a buck-boost DC/DC converter between the positive and negative poles of the battery, and use the high-speed switching characteristics of MOSFET to adjust the battery output voltage in real time through duty cycle control. When the temperature is too low, increase the duty cycle to obtain a higher output voltage, and provide a stable working voltage for the drive motor through inversion. At the same time, the output of the converter can also be used for battery power to achieve self-heating, helping the battery quickly return to normal operating temperature.

Keywords: New energy vehicles, Buck -boost converter, Lithium battery, Low temperature.

1. Foreword

In recent years, with the continuous advancement of new energy vehicle technology, China's electric vehicle market share is gradually expanding. Statistics show that the sales of new energy vehicles in China will reach 6.887 million in 2022, accounting for nearly 26 % of the car sales in that year. Electric vehicles have become a new bright spot and an important part of the growth of China's auto market with a growth rate of more than 90%. This is mainly attributable to the China's policy of vigorously supporting the development of new energy vehicles and the improvement of consumers' awareness of environmental protection. But EVs still face some hurdles before they can fully take over the mainstream. The main bottleneck lies in the battery technology. Existing lithium batteries have problems such as low capacity, long charging time, and limited cycle life, which seriously restrict the cruising range of electric vehicles. At low temperatures, the internal resistance of lithium batteries will increase disproportionately, seriously reducing the output voltage. These factors limit the market penetration rate of electric

vehicles to a certain extent.

At low temperatures, the available capacity and peak power of a Li-ion battery drops dramatically. S.Herreyre et al [1]. added ethyl acetate and methyl butyrate to ensure the low temperature performance of the lithium battery to solve the problem of poor conductivity of the electrolyte; some scholars also believe that a simple external heat source heating method can ensure that the lithium battery can be heated to Working temperature is the most practical method [2]. However, these ideas will make electric vehicles have an inevitable warm-up time when they are started at low temperatures. This article will analyse the current situation of the battery system of electric vehicles, and propose a solution based on the existing technology to ensure the operation of lithium batteries in electric vehicles at low temperature, so as to reduce the heating time and improve the experience of using electric vehicles.

2. Current Status of Lithium Battery Output in Winter in Northern China

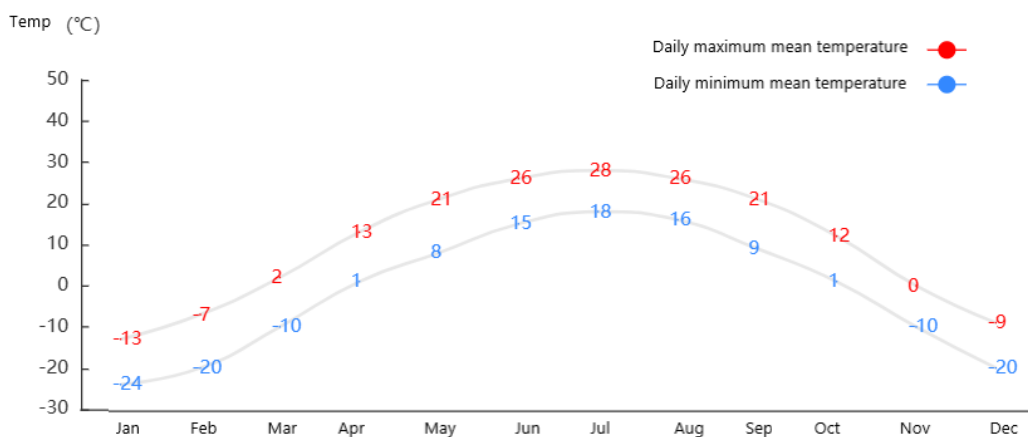

Figure 1. Annual mean air temperature of Harbin

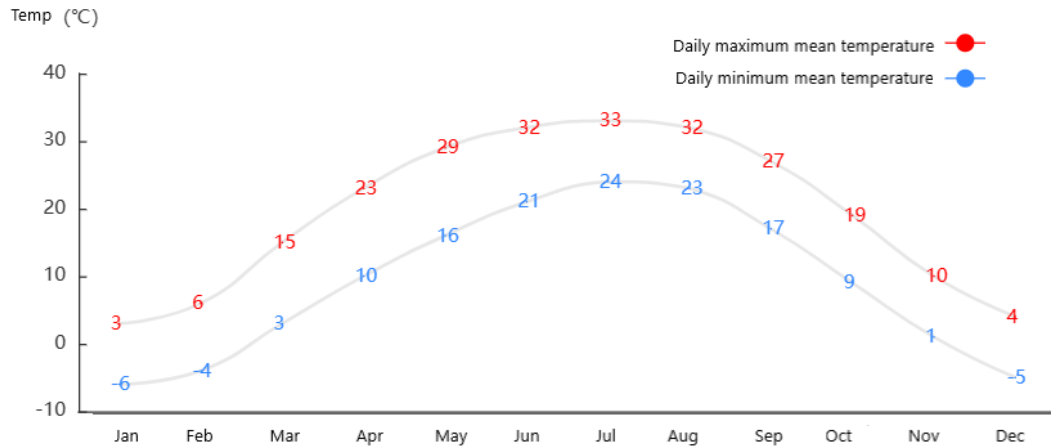

Figure 2. Annual mean air temperature of Beijing

Winter temperatures in northern China are generally low. In terms of distribution, winter temperatures are the lowest in the three northeastern provinces, followed by the Loess Plateau and the North China Plain. Northeast China is located in the mid-latitude continental climate zone, and is greatly affected by the cold air blowing from Siberia in winter. In addition, it is located in a high latitude and has weak sunlight, resulting in extremely low winter temperatures. The average winter temperature in the Northeast Plain is Between -15°C and -20°C [3]. Although the Loess Plateau and the North China Plain have lower latitudes, they are also affected by monsoon climate characteristics, and are frequently affected by cold air in winter. The two places also have a strong Mongolian high pressure in winter, and are often hit by cold waves. The average winter temperature for many years in the Loess Plateau and North China Plain is between -5°C and -10°C [4].

At low temperatures, especially at sub-zero temperatures, various performance indicators of lithium batteries will be attenuated to varying degrees, mainly manifested as capacity attenuation, power loss, power deterioration and output voltage reduction.

The main reasons for this phenomenon are as follows: First, under low temperature conditions, the viscosity of the electrolyte will increase significantly, thereby greatly limiting the migration speed of lithium ions. The slow movement of

ions will directly lead to poor conductivity of the battery and a decrease in peak power. Secondly, the low temperature will slow down the mass transfer rate on the electrode surface, leading to changes in the chemical reaction kinetics inside the battery, reducing the intensity of the reaction, and reducing the output power of the battery. Furthermore, the risk of lithium precipitation at the negative electrode increases when the lithium battery is discharged under low temperature conditions, resulting in a decrease in the number of lithium ions that are actually reversibly inserted and extracted, and a decrease in the available capacity. In severe cases, lithium metal precipitation may also occur, causing an internal short circuit in the battery. Finally, the superposition of the above effects will lead to a significant decline in the charge and discharge performance of the battery. The cycle life is shortened due to the increase of polarization; when the battery is charged at low temperature, problems such as copper foil dissolution and lithium deposition are very easy to occur, and the safety performance will also be affected [5]. In summary, low temperature conditions are an important factor leading to the rapid deterioration of lithium battery performance. And ensuring the output voltage of the lithium battery at low temperature can ensure that the output voltage meets the requirements of the motor, and can also ensure that the heating wire can work at a higher voltage to heat the lithium battery.

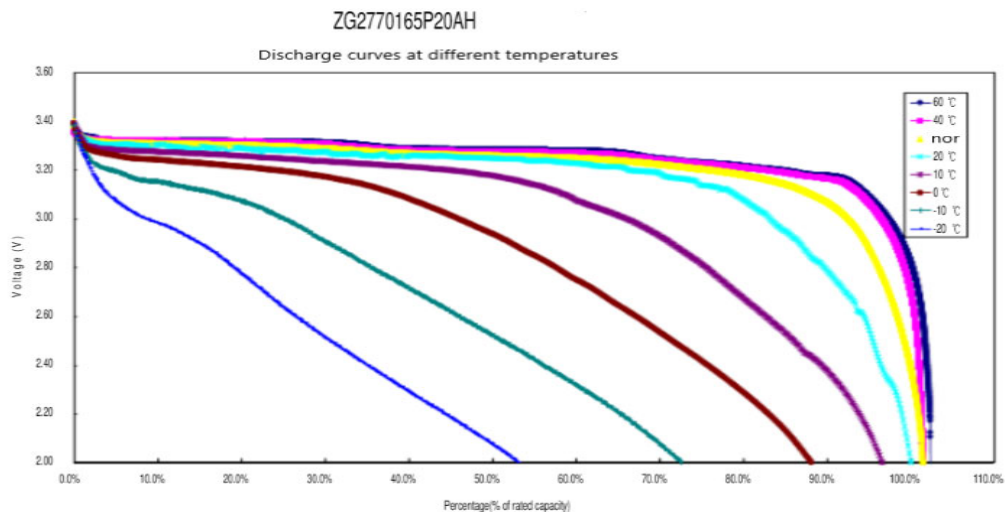

Figure 3. Discharge curves of lithium batteries at different temperatures

3. The Idea of Using a Buck-boost Converter to Ensure the Low Temperature Performance of Lithium Batteries

Buck-boost circuit structure is relatively simple, through a switch tube, a freewheeling tube, an inductor and two capacitors can complete the function conversion of step-up and step-down. The main advantages of this circuit structure include: the input and output voltage can have a large difference, and can be adjusted flexibly. The Buck-boost circuit can work both when the input voltage is higher than the output voltage (buck) and when the input voltage is lower than the output voltage (boost). This feature is mainly realized by adjusting the duty cycle. There can be a large ratio difference between the input and output voltages, which provides great flexibility for the selection of the power supply; the conversion efficiency is high, and the Buck-boost circuit can achieve high conversion efficiency compared with the linear regulator. Generally, it can reach more than 80% or even 95%, and the loss is very low. Moreover, the efficiency range is wide, and the efficiency does not change much under light load and heavy load conditions; the output voltage is stable, and the Buck-boost circuit adopts negative feedback control, which can effectively adjust the environmental changes and load changes, so that the output voltage has Very good stability. The error is within 1%; the structure is simple and the cost is low. The Buck-boost circuit only needs a few components to realize the function, and does not need to use multiple switch tubes like other circuits. Therefore, the circuit structure is very simple and compact, and the production cost is low, which is more beneficial to the automotive industry, which requires mass production; the control precision is high, and the Buck-boost circuit is easy to accurately control the output voltage. By changing the duty cycle, it can Smoothly adjust the output voltage; good reversibility, no power loss. The Buck-boost circuit can seamlessly switch between buck and boost states without power loss.

In summary, the Buck-boost circuit integrates the advantages of small size, high efficiency, low cost, and strong controllability, and is very suitable for occasions that require high stability and limited cost, which is advantageous.

The switch tube of the Buck-boost circuit is usually a MOSFET (metal-oxide field effect transistor), and the MOS tube will generally be positively affected by the reduction of power consumption and the increase of operating frequency in a low temperature environment. First of all, under low temperature conditions, the on-resistance of the MOS transistor will decrease, which is mainly due to the increase of the carrier migration speed and the decrease of the channel resistance. At the same time, due to the increase of carrier transfer speed, the switching time of the MOS transistor will also be shortened. The changes in these two aspects make the

on-state impedance of the power MOSFET smaller and the switching frequency performance is improved. Secondly, the low temperature environment will also increase the saturation leakage current of the power MOSFET. The reason is that the low temperature suppresses the heating effect of the drain region and can withstand a larger leakage current. In addition, under low temperature conditions, the transconductance of the MOS tube will also increase, because the low temperature reduces the influence of parasitic resistance.

Therefore, using the Buck-boost converter to ensure the output of the battery system at low temperature becomes an option, because its performance at low temperature is improved, which can reduce the loss of energy during the conversion process.

4. Design Ideas

In this scenario, the role of the buck-boost converter is to adjust the output voltage of the battery system so that the output voltage can reach the rated voltage of the engine after passing through the dc-ac inverter. If the input voltage is sufficient, the car can be started, which can reduce the heating time when the car needs to be moved, or move the car near the heat source. At the same time, the load of the battery system also includes the electric heating wire, which makes the battery temperature rise through electric heating, and transitions to the normal working temperature as soon as possible. The increase in battery temperature can accelerate the chemical reaction and help the battery return to the normal output voltage range as soon as possible. Finally, the opening and closing of the switching MOS tube and the freewheeling MOS tube are controlled by the control system of the electric vehicle, and the components of the control system usually have a lower rated voltage, which is easier to meet the requirements. By measuring the output voltage of the battery, the control system can precisely control the opening and closing of the switching tube and the freewheeling tube and the current flowing through the two MOS tubes. This action is controlled by the vehicle control system according to the measured real-time output voltage of the battery. Through precise adjustment of the duty cycle, when the duty cycle increases, the battery system output voltage increases; when the duty cycle decreases, the battery system output voltage increases. The voltage drops. Therefore, the duty cycle of the switching tube in the buck-boost converter can be accurately controlled by the vehicle control system to achieve stable adjustment of the output voltage of the battery system during the battery temperature rise and discharge process, ensuring that the output voltage can be adjusted after passing through the subsequent dc-ac inverter. Provide stable rated working voltage for the engine. By controlling the negative feedback control of the two MOS tubes, a stable output voltage can be guaranteed, and a stable and reliable operation of the circuit system can also be guaranteed.

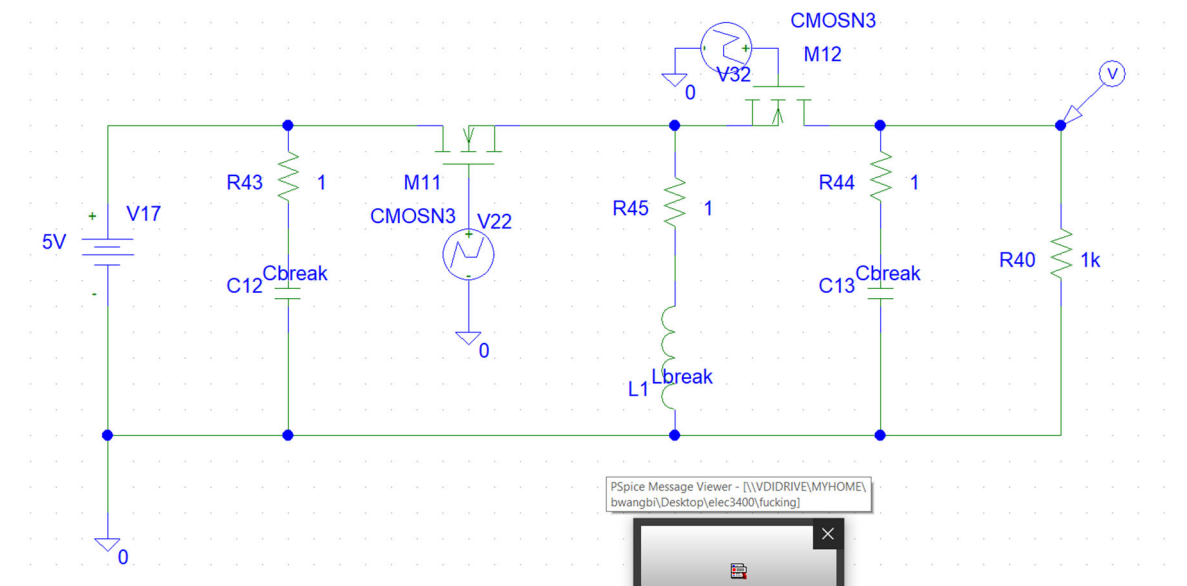

Figure 4. Buck-boost circuit

5. Conclusion

In new energy vehicles, the output performance of the battery system in a low temperature environment will be significantly reduced, and it will not be able to provide a stable power supply for the drive system. To solve this problem, this paper proposes to add a MOSFET-based buck-boost DC/DC converter between the positive and negative poles of the battery to adjust the output voltage of the battery in real time. The converter utilizes the high-speed switching characteristics of the MOSFET to control the rise and fall of the output voltage by changing the duty cycle. When the ambient temperature is too low, increase the duty cycle to obtain a higher output voltage to ensure that the voltage output by the battery can be converted by the inverter to provide a stable working voltage for the drive motor. At the same time, the output of the converter can also supply power to the heating wire, allowing the heating wire to heat the battery pack and help the battery return to the normal operating temperature range as soon as possible. In this paper, the working principle and control idea of the converter are described in detail, and the simulation verification is carried out through Pspice, and good simulation results are obtained.

In conclusion, the proposed MOSFET-based buck-boost DC/DC converter can effectively improve the output

performance of electric vehicle battery systems in low-temperature environments, and provide an effective solution for the low-temperature adaptability of electric vehicles. This method is worthy of further research and application.

References

- [1] Herreyre S, Huchet O, Barusseau S, et al. (2001) New Li-ion electrolytes for low temperature applications. *Journal of Power Sources*, 97: 576-580.
- [2] Tan W, Xu W, Chen K, et al. (2023) Research on low-temperature rapid preheating of special energy storage shelter battery system. *Energy Storage Science and Technology*.
- [3] Weather net. (2022) Annual mean air temperature of Harbin. https://www.tianqi.com/qiwen/city_/
- [4] Weather net. (2023) Annual mean air temperature of Beijing. https://www.tianqi.com/qiwen/city_haerbin/
- [5] Liu R, Shang L, Qu W. (2022) Discharge characteristics of lithium battery at low temperature. https://chn.oversea.cnki.net/KCMS/detail/detail.aspx?dbcode=CAPJ&dbname=CAPJLAST&filename=DYXB20220616002&uniplatform=OVERSEA&v=QaOd5zVGFLzVdyV_zb_pU9iPIV_pD-5xEDyePIT5kCAzn6_vxW75Zt_uiV3xrWIN