

UNIVERSITY OF THE ARTS LONDON



*Transforming structured descriptions to visual  
representations. An automated visualization  
of historical bookbinding structures*

ALBERTO CAMPAGNOLO

*Thesis for the degree of Doctor of Philosophy*

*Volume 1*

MAY 2015

# Abstract

In cultural heritage, the documentation of artefacts can be both iconographic and textual, i.e. both pictures and drawings on the one hand, and text and words on the other are used for documentation purposes.

This research project aims to produce a methodology to transform automatically verbal descriptions of material objects, with a focus on bookbinding structures, into standardized and scholarly-sound visual representations.

In the last few decades, the recording and management of documentation data about material objects, including bookbindings, has switched from paper-based archives to databases, but sketches and diagrams are a form of documentation still carried out mostly by hand. Diagrams hold some unique information, but often, also redundant information already secured through verbal means within the databases. This project proposes a methodology to harness verbal information stored within a database and automatically generate visual representations.

A number of projects within the cultural heritage sector have applied semantic modelling to generate graphic outputs from verbal inputs. None of these has considered bookbindings and none of these relies on information already recorded within databases. Instead they develop an extra layer of modelling and typically gather more data, specifically for the purpose of generating a pictorial output. In these projects qualitative data (verbal input) is often mixed with quantitative data (measurements, scans, or other direct acquisition methods) to solve the problems of indeterminateness found in verbal descriptions. Also, none of these projects has attempted to develop a general methodology to ascertain the minimum amount



of information that is required for successful verbal-to-visual transformations for material objects in other fields. This research has addressed these issues.

The novel contributions of this research include: (i) a series of methodological recommendations for successful automated verbal-to-visual intersemiotic translations for material objects — and bookbinding structures in particular — which are possible when whole/part relationships, spatial configurations, the object's logical form, and its prototypical shapes are communicated; (ii) the production of intersemiotic transformations for the domain of bookbinding structures; (iii) design recommendations for the generation of standardized automated prototypical drawings of bookbinding structures; (iv) the application — never considered before — of uncertainty visualization to the field of the archaeology of the book. This research also proposes the use of automatically generated diagrams as data verification tools to help identify meaningless or wrong data, thus increasing data accuracy within databases.

# Table of contents

## Volume 1

Abstract.....	ii
Table of contents.....	iv
Table of figures.....	x
Table of tables.....	xiv
Table of listings.....	xv
Acknowledgements.....	xvii
Chapter 1. Introduction.....	1
1.1. The cognitive importance of diagrams.....	4
1.1.1. Diagrams as visual proofs.....	5
1.2. Problems with the adoption of diagrams.....	6
1.3. Verbal to visual: intermediation & intersemiotic translations.....	7
1.3.1. The essential elements of the communication cycle.....	8
1.4. Bookbinding descriptions and the generation of diagrams.....	8
1.5. Terminological issues.....	11
1.6. Aims and objectives.....	12
1.7. Chapter overview.....	13
Chapter 2. Modelling & related work.....	16
2.1. Modelling.....	16
2.1.1. Modelling <i>of</i> and modelling <i>for</i> .....	18
2.2. From verbal to visual: related projects and approaches.....	19
2.2.1. Hardware description languages.....	19
2.2.2. Natural language processing.....	20
2.2.3. Cultural heritage modelling.....	22
2.3. From verbal to visual through models <i>of</i> .....	25
Summary.....	28

Chapter 3. Signs & material objects.....	30
3.1. Signs, signification, and communication.....	31
3.1.1. Signs.....	32
3.1.2. Reading and remembering iconic signs.....	34
3.1.2.1. Reading modalities of icons.....	34
3.1.2.2. Formalization of hypoicons.....	36
3.1.3. Visual texts.....	38
3.2. Multimodal communication.....	40
3.2.1. Dual-coding representation.....	41
3.2.2. Verbal recoding of ambiguous visual stimuli.....	42
3.3. Categorization and prototypification.....	43
3.3.1. Prototypes.....	43
3.3.2. Basic level of abstraction.....	45
3.4. Objects: their form and their shape.....	50
3.4.1. The form of objects.....	50
3.4.1.1. Material components and form.....	51
3.4.1.2. Logical form and expression.....	51
3.4.2. The shape of objects.....	53
3.4.2.1. The nature of shape.....	54
3.4.2.2. Regularities for the prototypification of shape.....	55
3.4.2.3. Line drawings.....	56
3.4.2.4. Perceptual biases.....	58
Summary.....	59
 Chapter 4. Bookbinding descriptions.....	 61
4.1. Books as artefacts.....	61
4.1.1. Binding structures and decoration.....	62
4.1.1.1. The evolution of bookbinding studies.....	63
4.1.2. Terminology.....	67
4.2. Verbal and visual descriptions of bindings.....	69
4.2.1. A description of Coptic bindings.....	70
4.2.2. A particular sewing pattern.....	71
4.2.3. A controlled vocabulary description.....	75
4.2.4. Structured and controlled vocabulary descriptions.....	77
4.3. Prototypical visualization of bookbinding elements.....	81
4.3.1. Gathering assembly diagrams.....	82
4.3.1.1. Naturalistic representations of gatherings.....	83
4.3.1.2. Schematic representations of gatherings.....	84
4.4. A categorization of bookbinding illustrations.....	87
4.4.1. Archaeological-style drawings.....	87
4.4.2. Naturalistic drawings.....	88
4.4.3. Line drawings.....	90
4.4.4. Generic-shape drawings.....	92

4.4.5. Scenes.....	93
4.5. Clarity of information in bookbinding line drawings.....	95
4.5.1. Sketchiness and detail views.....	97
Summary.....	101
Chapter 5. Communicating & translating objects.....	103
5.1. Communicating material objects through verbal means.....	104
5.1.1. Communicating through controlled vocabularies.....	105
5.1.1.1. Names and prototypical material components.....	107
5.1.1.2. Sewing structure controlled vocabulary.....	108
5.1.2. Communicating through structured descriptions.....	109
5.1.3. Diagrams as support for natural language descriptions.....	111
5.2. Automated intersemiotic translations.....	112
5.2.1. Translating material components, their form, and shape.....	112
5.2.2. Translating material objects' shapes.....	113
5.2.3. Translating an object's form.....	114
5.2.4. The reference to the logical form.....	114
5.3. Communicating material objects through visual means.....	115
5.3.1. Marks on a background.....	116
5.3.2. Continuity of the plane.....	117
5.3.3. Visualization conventions.....	117
5.3.3.1. Fixing meaning through a reference system.....	118
5.3.3.1.1. Titling and verbal labelling.....	119
5.3.3.1.2. Graphic reference elements.....	119
5.3.3.2. Separation of information.....	119
5.3.3.3. Use of colour.....	120
5.3.3.4. Two-dimensional vs. three-dimensional visualizations.....	121
5.3.4. Structured visualizations as output.....	121
5.4. The uncertainty of reality.....	122
5.4.1. Uncertainty in structured descriptions.....	125
5.4.2. Uncertainty in visualizations.....	126
5.4.2.1. Archaeological visualizations.....	126
5.4.2.1.1. An example from archaeology of the book.....	127
5.4.2.1.2. Uncertainty clues in archaeological visualizations.....	128
5.4.2.2. Irregularities in visual propositions.....	129
5.4.2.2.1. Visual cues for uncertainty visualization.....	129
5.4.2.3. Imprecision as uncertainty.....	132
5.4.2.4. Uncertainty inherent in the visualization process.....	132
5.4.3. Human error in the data.....	133
Summary.....	135
Chapter 6. Transformation framework.....	138

6.1. The technology and the description schema.....	139
6.1.1. Extensible Markup Language.....	139
6.1.2. Extensible Stylesheet Language Transformations.....	140
6.1.3. Scalable Vector Graphics.....	141
6.1.4. The description schema and the dataset.....	141
6.1.4.1. The <i>Ligatus</i> schema for the description of bookbinding structures....	142
6.1.4.1.1. The manuscript collection survey.....	142
6.1.4.1.2. The printed book collection survey.....	143
6.1.4.1.3. Free-hand drawings.....	145
6.1.4.2. The project dataset.....	146
6.2. The transformations.....	147
6.2.1. Knowledge graph schemas.....	147
6.2.1.1. Graphic conventions for knowledge graph schemas.....	149
6.2.1.2. Reading the visual description graphs.....	151
6.2.2. Number of possible visualizations.....	152
6.2.2.1. Board marker visualizations.....	153
6.2.2.2. Endleaf structure visualizations.....	154
6.2.3. Visualizations.....	157
6.2.3.1. Level of abstraction and semantic entry point.....	158
6.2.3.2. Diagram elements.....	161
6.2.3.3. Spatial arrangement.....	163
6.2.3.4. Thread paths.....	165
6.2.3.5. Uncertainty.....	166
6.2.3.6. Accuracy and imprecision of measurements.....	172
6.2.3.7. Place-holders for uncertainty inherent in the visualization process....	174
Summary.....	176
Chapter 7. Transformations & analysis.....	177
7.1. A complete visualization example: endleaves.....	178
7.1.1. Visual description framework.....	178
7.1.2. Shapes: standard endleaf components.....	179
7.1.2.1. Reference elements.....	181
7.1.2.2. Endleaf components.....	182
7.1.2.2.1. Pastedowns in <i>use</i> visualizations.....	182
7.1.2.3. Attachment modalities.....	184
7.1.2.3.1. Sewn.....	184
7.1.2.3.2. Glued.....	185
7.1.2.4. Component material.....	185
7.1.2.5. Spatial arrangement.....	186
7.1.3. Shapes: different types of endleaves.....	186
7.1.3.1. Integral endleaves.....	186
7.1.3.2. Separate endleaves.....	187
7.1.3.2.1. Single leaf.....	187
7.1.3.2.2. Fold.....	188

7.1.3.2.3. Hooks.....	188
7.1.3.2.3.1. Endleaf hook.....	188
7.1.3.2.3.2. Text hook.....	189
7.1.3.2.4. Outside hook.....	189
7.1.3.2.5. Guard.....	190
7.1.4. Visualization problems.....	190
7.1.4.1. Schema limitations.....	191
7.1.4.2. Schema misinterpretations.....	196
7.2. The set of transformations.....	202
7.2.1. Markers: page markers, board markers, bookmarks.....	202
7.2.2. Sewing.....	208
7.2.3. Boards.....	213
7.2.4. Spine shape and lining.....	216
7.2.5. Endbands.....	223
7.2.6. Coverings.....	224
7.2.7. Furniture.....	236
7.3. Dealing with erroneous data.....	237
7.3.1. Error examples.....	239
7.3.2. The feedback loop.....	242
Summary.....	244
Chapter 8. Recommendations.....	245
8.1. Intersemiotic translations: methodological recommendations.....	245
8.1.1. Intersemiotic translation elements.....	246
8.1.2. Functional verbal descriptions.....	246
8.1.3. The nature of sememes in diagrams.....	248
8.1.4. Prototypicality of information.....	249
8.1.5. Graphic prototypes.....	251
8.1.6. Fixing the meaning of visual sememes.....	252
8.1.7. Uncertainty.....	252
8.2. Recommendations for the communication of bookbinding structures.....	252
Summary.....	254
Chapter 9. Conclusions.....	255
9.1. Successful automated intersemiotic translations.....	256
9.1.1. Summary of the recommendations.....	257
9.2. Visualizations from models <i>of</i> .....	258
9.3. Standardized automated drawings of bookbinding structures.....	259
9.3.1. Summary of design principles.....	262
9.4. Uncertainty visualization in bookbinding studies.....	263
9.4.1. Summary of uncertainty visualization application.....	264
9.5. Added value & benefits of visualization automation.....	265

Chapter 10. Future work.....	268
10.1. Integration of automated transformations within the data gathering framework.....	268
10.2. Verbal to visual and reverse: a mixed approach.....	269
10.3. Related work: Manuscript Collation Project.....	271
10.4. Final remarks.....	274
Bibliography.....	275
Illustration credits.....	314
Volume 2	
Appendix A. Human memory system.....	318
Appendix B. Shape library.....	321
B.1. Page markers.....	322
B.2. Board markers.....	235
B.3. Bookmarks.....	328
B.4. Endleaves.....	335
B.5. Sewing.....	340
B.6. Boards.....	347
B.7. Spine shape.....	355
B.8. Spine lining.....	359
B.9. Endbands.....	368
B.10. Coverings.....	383
B.11. Furniture - fastenings.....	408
Appendix C. Coding example: endleaves.....	413
C.1. Endleaf XSLT.....	414
C.2. Endleaf master SVG.....	473
C.3. Endleaf CSS.....	476

# Table of figures

Figure 1. Exograms.....	5
Figure 2. Communication cycle.....	9
Figure 3. Example of Text-to-Picture transformation.....	21
Figure 4. Example of classical architecture column parts.....	26
Figure 5. Basic structure of signs.....	33
Figure 6. Mexican on a bicycle.....	35
Figure 7. Mexican on a bicycle — as seen from above.....	37
Figure 8. Units in visual language are context dependent.....	39
Figure 9. An angle growing from 0° to 180°.....	46
Figure 10. Dimensions of a category systems.....	47
Figure 11. Stirrup ring shape and its prototypified diagram.....	57
Figure 12. A sewing pattern for a Coptic binding.....	72
Figure 13. Knot-tack sewing.....	73
Figure 14. Knot-tack sewing: alternative solution.....	74
Figure 15. Unsupported sewing sample.....	75
Figure 16. Sewing photograph and drawing example.....	78
Figure 17. Archaeological drawings.....	83
Figure 18. Naturalistic and three-dimensional representations of gatherings....	84
Figure 19. Schematic representations of gatherings.....	85
Figure 20. Categorical dimensions of drawings.....	88
Figure 21. Archaeological-style drawings.....	89
Figure 22. Naturalistic drawings.....	91
Figure 23. Line drawings, the graphic basic level of abstraction.....	93
Figure 24. Generic-shape drawings.....	94
Figure 25. Bookshop scene.....	96
Figure 26. Well-shaped and free-hand thread paths.....	98
Figure 27. Drawing of an endband sewn at the frame.....	98
Figure 28. Sketch-like illustrations on how to work a Greek-style endband.....	99
Figure 29. Step 11.....	99
Figure 30. Line drawings of different styles of endbands.....	100
Figure 31. Diagram of the construction of the Nag Hammadi codices.....	127
Figure 32. Dashed lines indicating both invisible parts and folds.....	131
Figure 33. Paper survey form.....	144
Figure 34. Drawing survey paper form.....	146



Figure 35. Visualization of the <i>Ligatus</i> schema.....	148
Figure 36. Example graph schema showing the graphical conventions.....	152
Figure 37. Board-marker graph schema.....	154
Figure 38. Endleaf graph schema.....	155
Figure 39. Board visualization example.....	159
Figure 40. Example of mechanical drawing with three projected views.....	160
Figure 41. Fastening visualization example.....	160
Figure 42. Visualization of the <i>Ligatus</i> schema.....	162
Figure 43. Gothic binding bosses.....	163
Figure 44. Schematic endleaf drawings.....	164
Figure 45. Example of a complex endleaf structure.....	165
Figure 46. Examples of cross-section visualizations for endbands I.....	167
Figure 47. Examples of cross-section visualizations for endbands II.....	168
Figure 48. Conjoined double hook detail.....	170
Figure 49. Cross-section of endband with <i>no-front-bead</i> sewing.....	171
Figure 50. Fading off of board groove towards the spine.....	171
Figure 51. Front view of a double-core greek-style endband.....	173
Figure 52. Cross-section and front views of a stuck-on endband.....	174
Figure 53. Above view of a roller-round-bar catchplate.....	175
Figure 54. Sketchy lines and blurring to indicate uncertainties.....	176
Figure 55. Example of endleaf diagram.....	179
Figure 56. Complete set of endleaf diagram.....	179
Figure 57. Graph schema for endleaf diagrams.....	180
Figure 58. Example of integral endleaves.....	182
Figure 59. The five basic components of separate endleaves.....	182
Figure 60. Examples of schematic endleaf diagrams.....	183
Figure 61. Example of endleaf diagram with sewing thread convention.....	184
Figure 62. Example of glued component.....	185
Figure 63. Example of glued components.....	185
Figure 64. Endleaf structure with internal parchment guard.....	186
Figure 65. Example of a complex endleaf structure.....	186
Figure 66. Example of integral endleaves.....	187
Figure 67. Example of single leaf unit.....	187
Figure 68. Example of separate pastedown.....	187
Figure 69. Example of fold components.....	188
Figure 70. Example of endleaf-hook components.....	189
Figure 71. Example of text-hook component.....	189
Figure 72. Example of outside-hook component with text hooks.....	190
Figure 73. Example of guard.....	190
Figure 74. Hand drawing for the right endleaves.....	191
Figure 75. Example of endleaf diagram.....	192
Figure 76. Endleaf hand drawing example.....	192
Figure 77. Example of automated endleaf diagram.....	193
Figure 78. Example of endleaf drawing.....	193
Figure 79. Example of endleaf diagram.....	194

Figure 80. Detail of endleaf diagram.....	194
Figure 81. Example of endleaf hand drawing.....	195
Figure 82. Example of wrong endleaf diagram.....	195
Figure 83. Example of endleaf diagram.....	195
Figure 84. Example of wrong endleaf diagram.....	195
Figure 85. Example of endleaf hand drawing.....	196
Figure 86. Example of wrong endleaf diagram.....	196
Figure 87. Example of endleaf hand drawing.....	197
Figure 88. Example of endleaf diagram.....	197
Figure 89. Example of endleaf diagram.....	198
Figure 90. Endleaf diagram generated from corrected XML.....	198
Figure 91. Example of endleaf hand drawing.....	199
Figure 92. Example of visual output of an incorrect description.....	199
Figure 93. Endleaf diagram generated from corrected XML.....	199
Figure 94. Example of pagemaker diagram.....	203
Figure 95. Example of boardmarker diagram.....	203
Figure 96. Graph schema for pagemaker diagrams.....	204
Figure 97. Graph schema for boardmarker diagrams.....	205
Figure 98. Example of bookmarker diagram.....	206
Figure 99. Graph schema for bookmark diagrams.....	207
Figure 100. Examples of sewing diagrams.....	209
Figure 101. Example of sewing measurement diagram.....	210
Figure 102. Graph schema for sewing measurement diagrams.....	211
Figure 103. Examples of change-over stations.....	213
Figure 104. Example of sewing measurement diagram.....	214
Figure 105. Graph schema for sewing measurement diagrams.....	215
Figure 106. Example of board diagram.....	217
Figure 107. Graph schema for board diagram.....	218
Figure 108. Graph schema for board diagram.....	219
Figure 109. Graph schema for spine shape diagrams.....	219
Figure 110. Example of spine lining diagram.....	220
Figure 111. Graph schema for spine lining diagrams.....	221
Figure 112. Example of sewn endband diagram.....	224
Figure 113. Graph schema for sewn endband diagrams.....	225
Figure 114. Example of stuck-on endband diagram.....	226
Figure 115. Graph schema for sewn endband diagrams.....	227
Figure 116. Example of guard covering diagram.....	229
Figure 117. Graph schema for guard or drawn-on covering diagrams.....	229
Figure 118. Example of over-in-board covering diagram.....	230
Figure 119. Graph schema for over-in-board covering diagrams.....	231
Figure 120. Example of case covering diagram.....	232
Figure 121. Graph schema for case covering diagrams.....	233
Figure 122. Example of furniture diagram.....	234
Figure 123. Graph schema for furniture diagrams.....	235
Figure 124. Example of fastening photographs.....	237

Figure 125. Example of spine shape hand drawing.....	238
Figure 126. Example of spine shape diagram.....	238
Figure 127. Error due to schema convention misinterpretation.....	240
Figure 128. Error due to description convention misinterpretation.....	240
Figure 129. Error due to inaccurate encoding.....	240
Figure 130. Slip error during encoding.....	240
Figure 131. Project communication cycle.....	243
Figure 132. Errors in the hierarchical arrangement of elements.....	249
Figure 133. Small multiples.....	270
Figure 134. Screenshot from the Manuscript Collation Project webpage.....	273
Figure 135. A model of the human memory system.....	319

# Table of tables

Table 1. Samples of ambiguous visual stimuli.....	42
Table 2. Table showing the cause for error examples.....	242

# Table of listings

Listings 1. Snippet of XML description of a sewing station.....	79
Listings 2. Snippet of endleaf XML description.....	200
Listings 3. Corrected endleaf XML snippet description.....	201

# Acknowledgements

*Qual è 'l geomètra che tutto s'affige / per misurar lo cerchio, e non  
ritrova, / pensando, quel principio ond' elli indige, // tal era io a  
quella vista nova: / veder voleva come si convenne / l' imago al cer-  
chio e come vi s'indova*

*As the geometrician, who endeavours / To square the circle, and  
discovers not, / By taking thought, the principle he wants, // Even  
such was I at that new apparition; / I wished to see how the image  
to the circle / Conformed itself, and how it there finds place\**

Dante Alighieri, *The Divine Comedy: Paradise*, XXXIII, 133-138.

\*Henry Wadsworth Longfellow translation (1867)

I would like to express my sincere gratitude to Dr Athanasios Velios and Professor Nicholas Pickwoad, my research supervisors, for their guidance, and enthusiastic encouragement throughout this research work. My grateful thanks are also extended to the Arts and Humanities Research Council for funding this research and for giving me the opportunity to pursue it.

My most heartfelt thanks also go to Dr Elena Pierazzo, Dr Peter A. Stokes, Dr John Bradley, and Dr Raffaele Vigiante at the Department of Digital Humanities, King's College London for their support and for allowing me to attend, as auditor, their courses in 'Advanced Text Technologies: XML, TEI, XSLT' and 'Python Programming'. I am also indebted to Syd Bauman and Martin Holmes for their helpful course (and subsequent pointers) in XSLT programming 'Introduction to XSLT for Digital Humanities' at the Digital Humanities Summer Institute 2011, University of Victoria, BC, Canada. I would also like to thank the Social Sciences and Humanities Research Council of Canada and the Association of Computers and the Humanities for granting me a scholarship and

travel bursary to attend the workshop at the Digital Humanities Summer Institute 2011. My thanks also go to the Alliance of Digital Humanities Organizations for granting me a bursary to attend and present my paper at the Digital Humanities Conference 2013, University of Nebraska-Lincoln.

I would like to express my very great appreciation to Dr Alejandro Giacometti for his valuable suggestions on the management of my digital data and my research in general, and for his help in the development of an SVG filter for the rendition of sketchy lines. I would also like to extend my thanks to Dot Porter and Doug Emery at the University of Pennsylvania for allowing me to collaborate with them in their Manuscript Collation Project, and thus to test the methodology developed for this project on a different dataset. My gratitude also goes to Dr Arianna Ciula, my dissertation supervisor for the Master of Arts in Digital Culture and Technology at the Department of Digital Humanities (formerly Centre for Computing in the Humanities), King's College London for her interest, support, and stimulating questions and discussions during the course of this research.

I am grateful for the interest shown in my research by Professor Carlo Federici, Melania Zanetti, Director of the Associazione Italiana dei Conservatori e Restauratori degli Archivi e delle Biblioteche (Italian Association of Archive and Library Conservator-restorers), and Andrea Galeazzi, Director of *Kermes* — La rivista del restauro (*Kermes* — The Magazine of Conservation).

I am deeply thankful to Hilary Canavan for her language support and to her partner James Scott for accommodating me in their house. I am also grateful to Dr Caroline De Stefani for her support and for offering me a place to stay during my visits to London this last year.

Finally I would like to thank all my friends and colleagues at the Vatican Library. In particular I would like to thank Msgr. Cesare Pasini, Prefect of the Vatican Library, Dr Ambrogio M. Piazzoni, Vice Prefect of the Vatican Library, and Ángela Nuñez Gaitán, Head of the Conservation Workshop at the Vatican Library for allowing me to work flexibly and to take the necessary time off to finish this research. Special thanks also go to Elena Antonazzo, Sister Gabriella Pettirossi, Maria Rosaria Castelletti, Marta Grimaccia, Maruska Di Remigio, Pierre Sentagne, Silvia Foschetti, and Simona De Crescenzo for their support and patience. I would also like to thank Dr Luca Milasi for his support and for offering me a laptop on which to work in times of need.

Finally, I wish to thank my friends and family for their support and encouragement throughout my studies.

*Quidquid agis, prudenter agas, et respice finem*  
*Whatever you do, do it carefully, and with an eye to the end*

*(Unsere Probleme sind nicht abstrakt, sondern vielleicht die  
konkretesten, die es gibt.)*

*(Our problems are not abstract, but perhaps the most concrete  
that there are.)\**

Ludwig Wittgenstein, *Tractatus logico-philosophicus*, 1922.

\*translation by Pears & McGuinness (1961)



# Chapter 1. Introduction

*[La pittura] col suo principio, cioè il disegno, [...] insegna ai prospettivi ed astrologhi ed ai macchinatori ed ingegneri.*

*[Painting] with its principle, i.e. drawing, [...] teaches to perspectivists and astrologists and machiners and engineers.\**

Leonardo da Vinci, *Libro di pittura*, Biblioteca Apostolica Vaticana MS Urb.lat.1270, [ca. 1540], 12v. \*Author's translation

In the cultural heritage field, the documentation of artefacts is both iconographic and textual, i.e. both pictures and drawings on the one hand, and text and words on the other are used for documentation purposes.<sup>1</sup> This research project aims to advance a methodology to transform automatically verbal descriptions of material objects, such as bookbinding structures, into standardized and scholarly-sound visual representations.

Graphic-representation methods range from drawings, sketches and watercolours, to direct acquisition methods such as photographs, 3D scans, etc., and are an intrinsic part the surveying process.<sup>2</sup> During the last few decades, the recording and management of documentation data has switched from paper-based archives to databases and digital management systems.<sup>3</sup> Similarly, documentation entities that used to be analogue-based have increasingly been replaced by digital coun-

---

1. Szczepanowska 2013.

2. Drap *et al.* 2012; Kioussi *et al.* 2012.

3. Ravenberg 2012.

terparts. For example, photographs on glass-plate-negatives and slides have been replaced by digital photography, or surveying maps drawn over layers of translucent paper have been replaced by vector-based maps and geographic information system (GIS) technologies. Most surveying activities, in fact, have been influenced or replaced in one way or the other by digital technologies. Drawings are an important part of the survey process as their execution helps in understanding the object.<sup>4</sup> Computer-Aided Design (CAD) modelling or similar technologies are not a substitute for quick sketching, as these take time and effort, and cannot be quickly generated while surveying an artefact. For example, in archaeological surveys, drawing is the last form of documentation still carried out by hand, even if some projects have implemented the use of tablet computer technologies to substitute paper as a medium.<sup>5</sup> When not executed on a digital medium, the drawings are scanned and linked as images within the databases. There are also projects that have implemented retrospective conversion digitisation, which uses digital drawing software to capture lines from the scanned drawings and transforms these into vector graphics to allow for easy rescaling.<sup>6</sup>

The drawing process is then an important surveying tool which has remained virtually unchanged by the introduction of digital technologies. It is in essence an interpretative process that is visually encoded, through which the essence of an artefact, or its parts, is conveyed. These sketches are in general essentially diagrammatic line drawings.

Diagrams, and images in general, are important cognitive and representational tools for the human mind as they can be used not just for representation, but also as reasoning and cognitive tools. Our brain, in fact, devotes more than half of its processing power to vision.<sup>7</sup> We have limited information processing capabilities, but we are extremely adept at recognizing and analysing patterns, and visual patterns in particular.<sup>8</sup> When presented with visual information, this is immediately

---

4. Pickwoad 2004.

5. Warwick *et al.* 2009; Wright 2011.

6. Wright 2011. Vector images represent graphics by storing a series of mathematical equations describing a graphic object; these can be modified through parameters, retaining a high level of quality when transformed and scaled.

7. Lu & Doshier 2013.

8. Pizlo 2008; Terras 2008; Shin *et al.* 2013.

and integrally available to us, allowing us to perceive patterns and to compare features between different percepts quickly.<sup>9</sup>

Diagrammatic representations can be defined as two-dimensional entities composed of representing parts in mutual spatial and graphic relationships, which are directly interpreted as relationships in the entity described.<sup>10</sup> In other words, diagrams are composed of elements that refer to real-world entities. These elements are in relationship one with the other, and this network of elements mirrors the structure of the real-world entities that are being represented. Hand-drawn diagrams hold a great deal of information for interpreting and categorizing the structures there described, but they cannot be used as they are by a computer.<sup>11</sup> Some of this information is unique, but, coupled with the information recorded verbally, one finds a certain degree of information redundancy between the two modes of communication. The same kind of information about an artefact is, in fact, recorded within databases through verbal means as these guide the user to careful and conscientious attention to the evidence. Verbal information stored within databases has the added value of allowing for efficient and flexible retrieval of the information.<sup>12</sup> If the same essential information about an artefact is contained in both visual and verbal representations, it might be possible to use computing technologies to harness verbal information stored within a database and automatically generate visual representations. By linking the two representations it would be possible to present the information in graphic form to the user directly during the survey, and diagrams could be generated on the fly whenever needed. In this way, the information recorded verbally would also be available in graphic form. This would provide a standardized visual access to the verbal information and eliminate the need for redundant verbal and visual information, thus shortening the description process but still providing the added values of ‘visual intuition’,<sup>13</sup> and quick retrieval of verbal information.

---

9. Ware 2013.

10. Stenning & Lemon 1999.

11. Velios & Pickwood 2005a.

12. Eiteljorg 2004; Ramsay 2004.

13. Greaves 2002; Sandywell 2012.

This thesis outlines a methodology to transform verbal descriptions of material objects into visual representations automatically. In particular, the methodology will be applied to the field of bookbinding studies. Bookbinding structures are an ideal case study, as they range from simple to extremely complex and are, therefore, a good testing ground for the proposed methodology. Moreover, the archaeology of the book, the discipline devoted to the study of bookbinding structures (amongst other aspects of the materiality of books), is rather young, lacking in standards and rigorous methodologies, and it thus poses interesting additional issues and challenges.

### 1.1. The cognitive importance of diagrams

Diagrams are important cognitive devices. Donald<sup>14</sup> describes their importance as memory storage devices, which he calls *exograms* as they reside outside our minds. Their power resides in the fact that, by grouping information in a coherent way, they allow the human mind to exceed its limited working memory capabilities.<sup>15</sup> Working memory plays an essential role in our cognition, as it is in there that we maintain all relevant information during the performance of a cognitive task.<sup>16</sup> Data is naturally synchronous and simultaneous within diagrams, and this allows them to present information already arranged and grouped, which makes it effortless to ‘chunk up’<sup>17</sup> and to be given verbal labels that are easy to recall.<sup>18</sup>

Thanks to their ability to present information synchronously, diagrammatic representations have been used as heuristic problem-solving tools for a long time in domains that span from mathematics and geometry to architecture and engineering, to mention but a few.<sup>19</sup> Diagrams, in fact, exhibit expressive advantages over sequential representations, as they can show effortlessly spatial and whole-

---

<sup>14</sup>. Donald 1991; Donald 2001.

<sup>15</sup>. Miller 1956; Cowan 2001; Saaty & Ozdemir 2003; Gobet & Clarkson 2004; Ericsson & Moxley 2012. See also Appendix A.

<sup>16</sup>. Baddeley & Hitch 1974.

<sup>17</sup>. Baddeley 2013.

<sup>18</sup>. Brandimonte *et al.* 1992a; Brandimonte *et al.* 1992b; Brandimonte & Gerbino 1996; McCollough & Vogel 2007.

<sup>19</sup>. Shin *et al.* 2013.

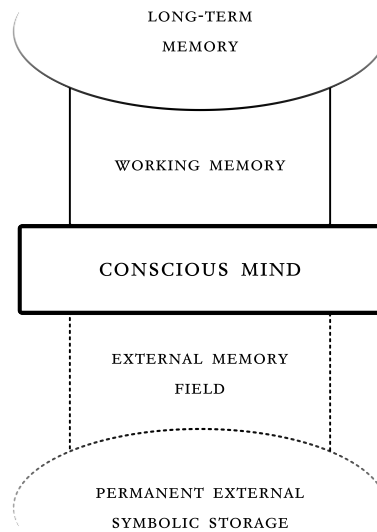

Figure 1. Diagram of the interplay between working memory and the external memory field embodied in *exograms*. The conscious mind sits in the middle of the two systems of representation, one inside and one outside (after Donald 2001, fig. 8.3, p. 311).

part relationships.<sup>20</sup> For example, maps are more helpful than verbal descriptions of a landscape when it comes to navigation,<sup>21</sup> or construction plans are the only efficacious way of showing workers all the information needed to construct an object designed by engineers.<sup>22</sup>

### III. DIAGRAMS AS VISUAL PROOFS

Diagrams have also exhibited uses as verification tools and visual proofs. Geometry is but one example of a domain that historically has made ample use of visual languages as proofs and verification systems; these are deductive techniques that exploit the topological and spatial features of diagrams and human spatial intuition. Intuition here means a non-deductive method by which we can infer

<sup>20</sup>. Allwein & Barwise 1996; Barker-Plummer 2002; Shin *et al.* 2013.

<sup>21</sup>. However, there are kinds of geographical information that can be encoded in texts, but which are impossible to express faithfully in maps (Eide 2012a).

<sup>22</sup>. Ferguson 1992.

classes of truths about the world.<sup>23</sup> Diagrammatic proofs, in fact, are linked to our ability to manipulate intuitively and interpret spatial relationships in diagrams, and in associating these with truths about the world.<sup>24</sup> Chapter 7 shows a possible use of the diagrams generated for this projects as data verification tools, linking the diagrams that have been automatically generated with the object represented.

## 1.2. Problems with the adoption of diagrams

Notwithstanding their undisputed usefulness, diagrams create a series of problems. One criticism that is often brought forward is that diagrams are cumbersome to reproduce or communicate.<sup>25</sup>

As mentioned above, hand-drawings are also not directly usable by a computer, and they have to be interpreted and provided with relevant metadata during data inputting by a human user.<sup>26</sup>

Also, they often hold redundant information, already secured through verbal means within the databases. Redundancy of information is not a problem in itself, as it is delivered through different means of communication; however, this does impact on surveying time as the same information has to be recorded twice during data input: once verbally and once graphically.

The proposed methodology aims to solve the problems of the generation, digitization, and reproduction of diagrams of bookbinding structures. This will allow automated diagrams to be promptly available during the surveying process, and for them to be effortlessly adopted as heuristic and communication tools, exploiting their intuitive spatiality and immediacy.

---

<sup>23</sup>. Greaves 2002.

<sup>24</sup>. Greaves 2002; Shin *et al.* 2013.

<sup>25</sup>. Hammer 1995; Greaves 2002.

<sup>26</sup>. Velios & Pickwood 2005a; Rains *et al.* 2014.

### 1.3. Verbal to visual: intermediation & intersemiotic translations

Going from verbal descriptions to visual graphic depictions involves two rather different information media. The relationship between information from different media is referred to as intermediality.<sup>27</sup> The passage of meaning between media is only one of the many aspects of intermediality, as this also express different experiences and narrations — i.e. how we experience, read, and interact with each medium.<sup>28</sup> This project is however focussed on the possibility of the passage of information from verbal descriptions to graphic representations, and it will only touch on the considerations of the different experiences that the two different media bring with them for the end-user.

The main concern here is the way in which a medium whose ‘semantic modality’<sup>29</sup> is characterized by symbolism — i.e. relying mostly on arbitrary signs — can be transformed into another medium whose ‘semantic modality’ is instead expressed mostly via iconism — i.e. relying on sign that resemble their object in some respect.<sup>30</sup> This is a problem of sign interpretation, or more accurately, a translation problem. Jakobson<sup>31</sup> distinguishes between three ways of interpreting a verbal sign: (i) intralingual translation or rewording, (ii) interlingual translation or translation proper, and (iii) intersemiotic translation or transmutation. The first case takes place when a verbal sign is translated into other signs of the same language; the second, when the verbal sign is translated into another verbal sign belonging to a different language; the last case refers to the verbal sign being translated into another sign belonging to a non-verbal system of symbols.

Intersemiotic translations deal with two different semiotic codes, turning meaning from one expression code into an entirely different one and present, therefore, complex issues. The automated transformations proposed by this research are a clear case of intersemiotic translations. This research will concentrate

---

27. Elleström 2010.

28. Elleström 2010; Ryan 2014.

29. Elleström 2010.

30. See chapter 3.

31. Jakobson 1959.

on the mechanics and procedures of intersemiotic translations of verbal descriptions of bookbinding structures into graphic representations.

### 1.3.1. THE ESSENTIAL ELEMENTS OF THE COMMUNICATION CYCLE

Looking at the project at hand it is possible to delineate a cycle which the relevant information should follow for a transformation from verbal to visual to be successful. In analysing the communication cycle<sup>32</sup> in more detail it can be seen how the project deals with a series of entities, processes, and agents. Specifically, there are three entities at play: the *object* being described — i.e. the source of the cycle — the *words* that are use to describe it in a verbal description, and the *image* used to represent it — i.e. the different message channels of the cycle. There are also two main processes: the *perception* and the *encoding and communication* of the relevant information. In addition, looking specifically at this project, there is a third process that needs to be taken into account: that of the *transformation* of information from a verbal encoding into its visual counterpart. Finally, there are two types of agent: a human agent that is both perceiving and communicating the information, on the one hand, and on the other receiving and interpreting the perceived information; and, looking specifically at this project, a computer agent set to transform a verbally encoded message into a diagrammatic representation. Figure 2[a] shows the diagram of a generic cycle going from verbal to visual, and Figure 2[b], the cycle specific to this project.

## 1.4. Bookbinding descriptions and the generation of diagrams

As it will be seen in chapter 4, bookbinding studies lack a systematic vocabulary, terminological clarity, and a precise recording system; in a similar way, they also lack graphic representation standards. Description of bookbinding structures are

---

<sup>32</sup>. Rothwell 2012.



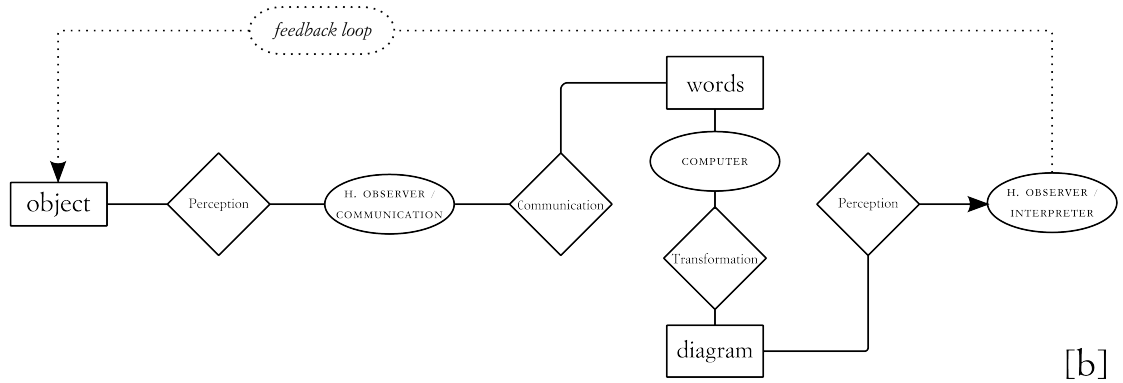
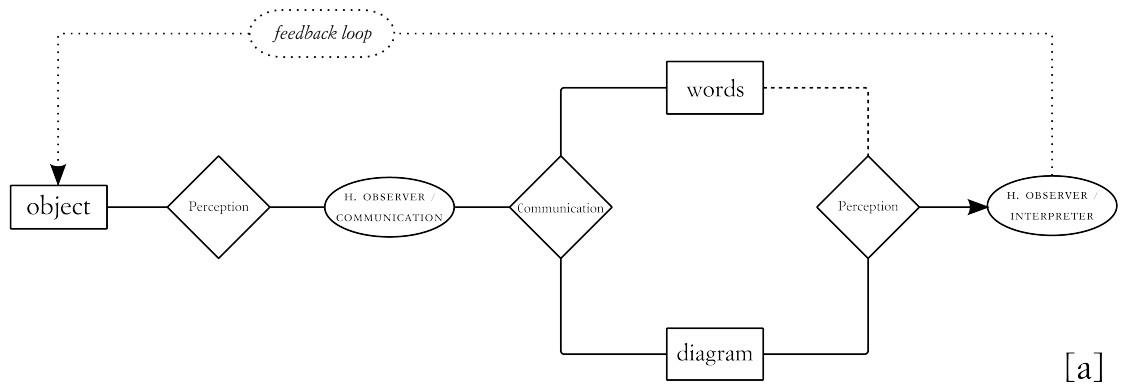

Figure 2. Communication cycle from the object being described — the source — to the human receiver/interpreter showing the three entities (object, words, images), the three processes (perception, communication, transformation), and the two types of agents involved (human being, computer).

(a) A cycle comprising of a verbal description and/or a visual depiction as message channels. The line from the verbal description to the perception process leading to the human receiver/interpreter has been dotted because, although strictly speaking there is still perception involved in the recognition and processing of written code (Dehaene 2009), its impact on the decoding and understanding of the message is limited by the highly symbolic nature of the medium.

(b) The particular communication cycle of a process whereby a verbal description is transformed by a computer into a visual description, which has then to be interpreted and understood as a proper description of the original object by a human receiver. Note the feedback loop checking for the effectiveness of the description of the source material.

therefore often ambiguous, and this hinders comparison, sharing of information, and, inevitably, progress in the field.

Diagrams and sketches are often used as cognitive devices when describing bookbinding structures because of their innate capacity of showing effortlessly spatial and whole-part relationships. They facilitate communication, to the point that purely verbal descriptions of bookbinding structures are often completely inadequate as communication devices.<sup>33</sup> However, to this author knowledge, bookbinding diagrams have never adopted methods of uncertainty visualization, leading to the impossibility of scholarly transparency in graphic representation of bookbinding structures.

As in the case of the documentation of artefacts in other fields within the cultural heritage sector, also databases devised to describe bookbinding structures often contain both iconographic and textual information, following the usual practice of accompanying words with visual representations for easier communication, thus creating a redundancy or overlapping of information.

This project will aim at exploiting that redundancy, investigating the possibility of automatically generating bookbinding structure diagrams from verbal description within databases. As it will be seen, it is possible to generate such diagrams, and these, being standardized, allow easier comparison amongst similar structures in different books. The fact that these are automated diagrams, also permits their use as visual proofs, thus leading to better data being recorded within databases.

In addition, thinking in terms of intersemiotic translations, permits to identify efficient description modalities that can inform any bookbinding description methodology, whether automated diagrams are included or not.

The contributions of this research to the field of bookbinding studies offer a way to improve communicability of information and scholarly transparency, thus fostering the progress of the discipline.

---

<sup>33</sup>. See §4.2.1-2.

## 1.5. Terminological issues

It is important to clarify three similar, but separate concepts: *shape*, *form*, and *structure*. *Shape* refers to ‘those geometrical characteristics of a specific three-dimensional object that makes it possible to perceive the object veridically from many different viewing directions, that is, to perceive it as it actually is in the world out there.’<sup>34</sup> *Form* refers to the structural organization of material objects, i.e. the configuration or arrangement of the components of a material object; in chapter 3, a further specification of *form* will also be introduced, referred to as *logical form*. Both these terms are clearly synonyms of *structure*, however, the term *structure* is used only in reference to bookbinding structures — e.g. a particular kind of endband, a sewing pattern, etc. — to thus avoid having to speak of ‘the structure of a binding structure’ creating unnecessary confusion; such a concept will thus be expressed as ‘the form of a binding structure.’

In this project, the terms *diagram*, *diagrammatic drawing*, or *diagrammatic representation* will be taken to signify an outline drawing of a bookbinding structure showing parts and their relationships.

Finally, the terms *verbal* and *visual* are intended throughout this thesis as cognitive psychological coding modalities. The former refers to any word-based communication or cognition process, often in contrast to things, realities, visual information, or to the fact that some information pertains to, or is manifested in words. The latter, instead, is related to sight and vision, what can be obtained through vision, what is carried out by vision, or what is produced or occurs as a picture in the mind.<sup>35</sup>

---

<sup>34</sup>. Pizlo 2008, p. 1.

<sup>35</sup>. Neisser 1967/2014; Paivio 1971; Paivio 1986; Oxford English Dictionary 2015a; Oxford English Dictionary 2015b.

## 1.6. Aims and objectives

The overall aim of the project is the generation of an automated diagrammatic visualization of bookbinding structures based upon structured verbal descriptions contained in a database.

Because these transformations are based on a model *of* the structures, some of the problems encountered by the examples in the last section will need to be considered in relation to the fact that, as it will be seen, bookbinding descriptions do not hold spatial data or detailed measurements. Amongst these problems are the placements of the components in space, and the specificity of the objects (measurements and shape).

In order to generalize a verbal-to-visual approach for material objects, one needs to be able to:

identify the minimum amount of information that is needed for a visualization of bookbinding structures, or other material objects. A successful visualization is one that is able to convey the minimum information required for the object represented to be recognizable.

assert whether a model *of* bookbinding structures can indeed lead to successful visualizations.

In addition to these, as noted in chapter 1, diagrams are often used as visual proofs. Considering that the visualization approach proposed in this project gathers data directly from a database and is therefore strictly connected with the data recorded there, one can:

assess whether automated diagrams of bookbinding structures can be used as data verification tools.

It also useful to set a series of practical objectives for the generation of successful automated visualizations of bookbinding structures:

Selection of bookbinding structures to be visualized from the information available within the *Ligatus* schema.

Selection of the characteristics of the appearance of the visualizations, taking into consideration perception, cognitive psychology, communication theories, and graphic conventions.

Identification of shapes for each transformation, their visual and formal characteristics.

Identification and selection of the most useful and appropriate technologies for the generation of the automated visualizations.

Identification of suitable strategies to visually communicate the various degrees and typologies of uncertainty and, where necessary, imprecision inevitably contained in the data to be visualized.

Compilation of coding to transform the verbal information on bookbinding structures contained in the XML data into visuospatial information integrated with befitting verbal labels.

## 1.7. Chapter overview

This introduction has introduced the fundamental concepts behind the starting point of this project. Diagrams are an important source of information. They can convey spatial and parthood<sup>36</sup> information better, and in more immediate ways than sequential communication systems. Also, during surveys, some information is collected redundantly both verbally and visually, but it is more easily absorbed through visual communication systems. It is, therefore, valuable to investigate the possibility of automatically transforming verbal information into graphic representations automatically, saving time and augmenting its possible uses. This kind of automated intersemiotic translation system requires the understanding of both modes of communication, their perception, and the mechanics of the transfer of

---

<sup>36</sup>. In philosophy, the relational quality of being a part. (Varzi 2014).

meaning from one sign-language to the other. This work will look at the entities and communication forms involved, the translation process, and the application of automated intersemiotic translations to the field of the study of bookbinding structures.

Chapter 2 considers the process of modelling reality, including material objects, and also considers previous projects that aimed at transforming information automatically from verbal to visual. It then sets a series of primary objectives for this investigation.

Chapter 3 looks into the nature of the various languages and entities involved in the project — words/verbal and images/visual — and their nature as signs bearing meaning. It also covers the fundamental processes of perception and prototypification,<sup>37</sup> while considering what is the minimum amount of essential information for the communication of a material object.

Chapter 4 provides an overview of the various kinds of verbal and graphic depictions of bookbinding structures found in the literature. These are categorized and analysed in reference to their efficacy in delivering their message.

Chapter 5 discusses verbal and visual representations of material objects, and the translation between languages. It also investigates the nature of visual communication devices and the expression of the uncertainty of information.

Chapter 6 introduces the technological aspects of the automated transformations, including the database description schema, and the dataset to which the transformations have been applied. Visualizations issues and considerations are explored in relation to the automated diagrammatic representations of bookbinding structures.

Chapter 7 examines in detail the transformation of endleaf structures and introduce generally all other transformations of bookbinding structures. It then considers the human factor in the data input process and the errors in the dataset.

---

<sup>37</sup>. In cognitive psychology, prototypification is a general feature of conceptualization, a process through which conceptual and perceptual prototypes are formed and elaborated in our mind. (Rosch 1978; Leyton 1987; Bossche *et al.* 1992).

Chapter 8 presents a set of recommendations for the practical task of transforming information from a verbally encoded dataset to series of meaningful and scholarly sound diagrams.

Chapter 9 draws conclusions from the project and declares what contributions were made in the course of this research, whilst Chapter 10, explores related and future work.

The Appendices cover an overview of the human memory system, a detailed examination of all the shapes and elements developed in the course of the project for the generation of the automated diagrams of bookbinding structures, and an example of the coding involved in one transformation.

# Chapter 2. Modelling & related work

*Each language speaks the world in its own ways. Each edifies worlds and counter-worlds in its own mode.*

George Steiner, *Real presences. Is there anything in what we say?*, 1989/2010, p. 63.

When we want to study a material object we initiate an abstraction, categorization, and modelling process.<sup>38</sup> This process allows us to select only a restricted set of its characteristics, and to work with these models of reality. Reality, in fact, varies from instance to instance and has an unwieldy amount of detail.

When we want to communicate a description of such an object, we use a similar strategy: we can use representations or models of reality that convey a restricted set of characteristics of the object for which they stand.<sup>39</sup> These models of reality can take various forms, each of which can be used for different purposes.

This chapter looks at the different kinds of modelling and communication systems that are involved in this project. It also defines where this project stands in relation to other projects and methodologies that go from verbal to visual.

## 2.1. Modelling

In order to study and communicate research results, a common and essential academic activity is that of modelling the reality that needs to be described.

---

<sup>38</sup>. Cohen & Lefebvre 2005.

<sup>39</sup>. Sebeok 1994.



Through a process of abstraction, the researcher, considering which research questions need answering, determines what aspects of the real world need to be included, and the granularity and level of detail the final model will need to have. Conceptual modelling requires decisions and assumptions in regard to the scope of the model, its level of detail, the nature of the reality to be described, and the simplifications to be made.<sup>40</sup>

The modelling activities take different forms. Amongst these forms McCarty<sup>41</sup> lists *analogy*, *representation*, *diagrams*, and *maps*. Maps are defined here as any *schematic spatial representation*.<sup>42</sup> Each of these forms can be either analogical or digital, and their boundaries can be blurry, one model being possibly associated with more than one form.

When dealing with material objects, the modelling activities can take any of the forms listed. (i) *Analogies* and *representations*, as there needs to be a relationship between the model and the artefact, so that by studying the former one can infer facts about the latter. (ii) *Diagrams* and *maps*, for the fact that models represent the structure, spatiality, and relationships between the essential parts of the artefacts.

Typically, analogy and representation models of material objects take the form of descriptive or database schemas. Databases are often used to record information on bookbindings, especially in the field of conservation.<sup>43</sup> Also, in archaeology, classics, and libraries, databases have been used for data management since the 1970s.<sup>44</sup>

Diagrams and maps are used to represent material objects. Because of the immediate way of conveying spatial and complex structural information, diagrams are considered as an integral part of record keeping.<sup>45</sup>

---

40. Kotiadis & Robinson 2008.

41. McCarty 2005.

42. McCarty 2005.

43. Ravenberg 2012.

44. Eiteljorg 2004; Terras 2008.

45. Eiteljorg 2004.

## 2.1.1. MODELLING OF AND MODELLING FOR

As mentioned above, a model is the result of decisions and assumptions in regards to its scope.<sup>46</sup> Considering the final scope of the modelling process, scholars<sup>47</sup> distinguish between two different activities: the modelling *of* reality, and the modelling *for* something. McCarty<sup>48</sup> defines the former as ‘a representation of something for the purposes of study’, and the latter as ‘a design for realizing something new’. In the first case, the model, denotative and descriptive in nature, renders reality and its physical relationships apprehensible and serves the scope of developing a theory of such a reality; it tends towards the general. One can think of models *of* as a sort of recipe that describes how an object can be composed — e.g. a table composed of a surface and a set of legs. Different instances of tables may have different number of legs, but by referring to the same model/recipe, one can compare each instance with the rest. In the second case, the theory behind the modelling process is exemplary in nature and guides the manipulation and organization of entities and their relationships for the creation of something new; it tends towards the particular.<sup>49</sup> By nature, both kinds are simplified representations. Modelling *of* is in reference to an idealized reality and helps to describe and understand it. Modelling *for*, instead, aims at the creation of new entities as heuristic and pragmatic instruments of investigation (often through manipulation).<sup>50</sup>

The two types of modelling activities can then be regarded as distinct, each with specific conceptual characteristics. This, however, does not mean that one cannot turn into the other, often in a cyclic system, that aims at gaining better and more detailed knowledge of the reality being modelled.<sup>51</sup>

Database design is a typical example of a modelling *of* process. Diagrams and maps can be either models *of* or models *for*. An architectural plan, for example, is a diagram/map that is used to generate something new, and is, therefore, an example of modelling *for*. However, if the same plan was, in fact, the result of the

---

46. Kotiadis & Robinson 2008.

47. Goodman 1976; Geertz 1973; McCarty 2005.

48. McCarty 2005, p. 24.

49. Goodman 1976; Geertz 1973; McCarty 2005.

50. McCarty 2005.

51. Geertz 1973; McCarty 2005.

conceptual reconstruction of the layout of a historical building, based on archaeological evidence, then that plan, in the first instance, would be a model *of*. The project at hand, as it will be seen, deals with models *of*.

## **2.2. From verbal to visual: related projects and approaches**

This project aims to transform automatically verbal descriptions of bookbinding structures to visual representations. Also, as there is not a highly structured and symbolical way to represent bookbinding structures in diagrams, the visual representations necessarily need to resemble the object that they represent. Therefore, this research needs to consider the transformation of information from verbal to visual, the implications of its automatism, and the iconicity of its output.

In the literature, one encounters a range of projects, standards and established practices of modelling and design based on verbal input to generate parametrically visualizations of objects by algorithmic means; although none of these projects considers bookbinding structures.

### **2.2.1. HARDWARE DESCRIPTION LANGUAGES**

One example is that of the Hardware Description Languages (HDL) used to describe the structure of Circuit Boards (CB) to then automatically program their design and function. HDLs are textual modelling languages based on standard high-level text-based computer-interpretable expressions that describe the structure of an electronic circuit board. This modelling is both physical, as it relate the various components in space, and functional, as it can mimic the interactions between the components and the final functions of the circuit. The circuit is then virtually tested and eventually physically printed.<sup>52</sup> Before the design is programmed through HDLs, the engineer has worked a higher-level model of the circuit, and it is this model that is then translated into the CB. This makes the HDL modelling

---

<sup>52</sup>. Mermet 1993; Ullman 2010.

stage clearly a modelling *for* activity, whose purpose is not that of study of the principles of circuits in general, but the manufacturing of a specific functional circuit. Also, in this example, the placement of items on the plane is guided by logic: the aim is to put in the desired circuit components using the least amount of space and in the most efficient way. The reference model is the idea of the circuit devised by the engineer, not an object.

## 2.2.2. NATURAL LANGUAGE PROCESSING

Since the late 1980s, a number of Artificial Intelligence (AI) studies have focused on the interpretation of verbal descriptions in natural language for the generation of visual scenes. In 1984, Adorni and colleagues<sup>53</sup> developed a strategy for depicting a static scene described by means of a sequence of predefined phrase-forms. Bijl<sup>54</sup> advances a methodology that looks at integrating AI studies with Computer-Aided Design (CAD) for the structuring of information and recovery of construction semantics from natural language. A concept then revisited by Coyne and colleagues<sup>55</sup> and extended in order to express the importance of functional knowledge in design from natural language.

Coyne and Sproat<sup>56</sup> presented a system to convert text to representative scenes automatically. Their system was aimed at the general public to allow scene modelling without having to deal with programming languages. Their software is restricted to its own database for semantics and objects.

Johansson and colleagues<sup>57</sup> advanced a method to convert (Swedish) narratives describing road accidents into graphic scenes. Texts are analysed by a natural language processor and converted into a symbolic representation of the scene that highlights nodes (objects), relationships, quantities, events, and the environment. Symbolic representation works in such a way that on the one hand it captures

---

<sup>53</sup>. Adorni *et al.* 1984.

<sup>54</sup>. Bijl 1986.

<sup>55</sup>. Coyne *et al.* 1990.

<sup>56</sup>. Coyne & Sproat 2001.

<sup>57</sup>. Johansson *et al.* 2004; Johansson *et al.* 2005.

enough information for visual modelling and, on the other hand, it is close to the way in which a human would read and describe a scene. Environmental information aids spatial framing of the objects and their movements.

Zhu and colleagues<sup>58</sup> modelled natural language processing in a similar way to text-to-speech synthesis to convey the gist of texts. Their system basically recognizes words denoting objects and actions, then looks for pictures that can offer the desired meaning. The images are then presented in a loose structure to the viewer (see Figure 3 for an example).



Figure 3. Example of Text-to-Picture transformation (from Zhu *et al.* 2007, p. 1590).

More recently, Claude-Lachenaud and colleagues<sup>59</sup> have presented an algorithm designed to visualize the movement of objects expressed in text sequences through verbs. By means of natural language processing, action words are detected, and movement identified in verb-to-motion tables. Trajectories that could be defined as random towards a general direction — e.g. to walk: onward generic direction; to climb: random vertical motion — were interpreted correctly by the system.

A common problem for all of these projects is the ambiguity of spatial information encoded within natural language. Motion verbs may only indicate general direction unless some kind of reference frame is provided as in the case of car

---

<sup>58</sup>. Zhu *et al.* 2007.

<sup>59</sup>. Claude-Lachenaud *et al.* 2014.

accident descriptions.<sup>60</sup> Spatial prepositions are often ambiguous too, as each can convey a series of different meanings.<sup>61</sup> Consider, for example, the different spatial meaning of the preposition *on* in the following sentences: (i) the book is *on* the table; (ii) the painting is *on* the wall. In both cases, the preposition indicates contact with some surface, but the surface is horizontal in (i) and vertical in (ii).

Similar problems are highlighted in a recent project that has investigated the passage of information from verbal description of landscapes to maps. Eide<sup>62</sup> considers what kind of information can be transformed and classifies textual spatial expressions in ‘fully specified’, and ‘underspecified’ ones. A fully specified text is one from which only one map can be drawn: every entity is fully specified geometrically. Examples of these are texts in formal languages, such as GML. On the other hand, more than one map can be drawn from an underspecified text, and some of these maps can be significantly different. The under-specification derives from the fact that natural language does not indicate direction and spatiality in absolute terms. For example, East of some place does not mean at 90° from the point of observation, but rather a range of possible locations roughly in an eastern direction.

These projects make use of models *for* the generation of their visual output, but in the first step, they generally model the reality they are dealing with as models *of* in order to be able to extract relevant information from texts. Examples of these model *of* are the semantic modelling at the basis of Eide’s investigation, or the symbolic scene representation found in Johansson and colleagues.

### 2.2.3. CULTURAL HERITAGE MODELLING

There have been applications of semantic modelling — i.e. verbal-based modelling — applied to the cultural heritage field. The aim of these projects is to allow for modelling without the designer having to learn how to use complicated mod-

---

<sup>60</sup>. Johansson *et al.* 2004; Johansson *et al.* 2005.

<sup>61</sup>. Boggess 1978; Boggess 1979; Herskovits 1980; Adorni *et al.* 1984; Ferrier 1996; Garrod *et al.* 1999; Tyler & Evans 2003; Lockwood *et al.* 2006.

<sup>62</sup>. Eide 2012a; Eide 2012b; Eide 2013; Eide 2014.

elling suits such as Computer-Aided Design (CAD), three-dimensional (3D) modelling software, or similar.

Stilla and Michaelsen<sup>63</sup> resort to knowledge representation through associative networks<sup>64</sup> to allow experts to model man-made objects found in aerial photographs. Complex shapes are described as a series of primitive elements combined together through logical operations. The modelling activity is focussed on the production of two-dimensional (2D) shape renderings of the buildings found on the photographs.

De Luca and colleagues<sup>65</sup> describe a methodological approach to the modelling of classical buildings based on verbal inputs and the mapping of photographs and 3D scanning data onto the semantically produced model. A similar project, focussed on the semantic modelling of vernacular buildings of South-east China, is presented by Yong Liu and colleagues.<sup>66</sup> These projects aim to decrease the complexity and workload of the modelling task for the designers, by utilizing<sup>67</sup> or developing<sup>68</sup> a formalized description language. Formal language allows one to increase the modelling level from the usual basic graphic units (points, lines, triangles, curves, etc.) to a higher level of semantic elements (walls, windows, roofs, houses, streets, etc.) which are intelligible by humans, and interpretable by a computer. It is interesting to note the fact that De Luca and colleagues base their semantic interface on the highly formalized language of classical architecture: in particular the works by Palladio and Vitruvius.<sup>69</sup> The technical language of classical architecture is well equipped to describe components and their spatiality.<sup>70</sup> In chapter 5, this will be analysed in more detail.

During modelling, the user inputs data verbally into the system that in turn transforms it immediately into a visual representation. Thus, the parameters defined through verbal input are modified until the desired output has been

---

<sup>63</sup>. Stilla & Michaelsen 1997.

<sup>64</sup>. Findler 1979.

<sup>65</sup>. De Luca *et al.* 2005; De Luca 2013.

<sup>66</sup>. Yong *et al.* 2006.

<sup>67</sup>. De Luca *et al.* 2005; De Luca 2013.

<sup>68</sup>. Yong *et al.* 2006.

<sup>69</sup>. De Luca *et al.* 2005; De Luca 2013.

<sup>70</sup>. Goulette 1999; Borillo & Goulette 2006.

produced. Measurements are provided by direct input in Yong and colleagues, whereas in De Luca and colleagues the model is adjusted and registered to fit the data from the 3D scans and the digital images of the building. The modelling activities in these projects are *for* the generation of specific models.

Another approach to produce large scale visualization efforts utilized in the cultural heritage sector is that of procedural or parametric modelling. This approach allows for rapid prototyping, i.e. the generation of series of models all assembled at random on the basis of specific prototypical models and parametric ranges of values. Müller and colleagues,<sup>71</sup> expanding on the procedural shape grammar advanced by Stiny,<sup>72</sup> have developed a system to build large architectural models with significant geometric detail. Dylla and colleagues,<sup>73</sup> have applied procedural modelling to rebuild virtually ancient Rome at the height of its urban development in 320 AD. The placement of the buildings is derived from Geographic Information System (GIS) data. Saldana<sup>74</sup> investigates the value of the modelling process behind the outcomes of the subsequent rapid prototyping as an important scholarly activity and as an information-rich source for each randomly designed model. This modelling process is prototypical in nature as it describes types of buildings rather than specific buildings, and it is implemented *for* the generation of a visualization.

In all these examples, the models on which the automated transformation from verbal to visual are based are models *for* the generation of the desired graphic representation. These models represent an extra layer of modelling, separated from survey database data, that has been conceptualized specifically for the sole scope of generating those graphic outputs from verbal or high-level inputs, and they have done so successfully.

---

71. Müller *et al.* 2006.

72. Stiny & Gips 1972; Stiny 1980; Stiny 2006.

73. Dylla *et al.* 2010.

74. Saldana 2014.



### 2.3. From verbal to visual through models *of*

The novelty of this project does not lie strictly in the fact that it advances a methodology for going algorithmically from verbal to visual - although this does lead to implications and considerations that are specific to this methodology - but rather in the fact that, unlike other cultural heritage projects, it uses a model *of* and not a model *for* as its starting point. In other words, instead of relying on additional information specifically introduced, according to a model *for*, for the generation of the graphic output, this research project will take the information directly from a survey database. The approach is not just technically, but also epistemologically different: it relates to the selection and processing of information, and to the nature of the outcome. As will be seen, in fact, the diagrams generated through this methodology are necessarily prototypical in nature; this renders them also graphic models *of* the object depicted, thus facilitating comparison, analysis, classification based on visual clues, and, to an extent, memorization. In addition to this, no other project has tried to produce automatically drawings of bookbinding structures.

A typical problem of words-to-image transformations is that of the spatial relationships between the various components. In the cultural heritage examples exposed above, the focus of the modeller is the production of two- or three-dimensional models utilizing semantic parameters and descriptions in order to visualize a specific object. The typical visualization problems of the placement of elements in space and of their dimensions are solved by turning to additional quantitative data (GIS data, 3D scan data).

Another problem is that of the shape of the objects to be represented and their specificity. In the Rome 2.0 project,<sup>75</sup> specific parts that are known because they still exist are manually designed using parameters such as exact measurements and texturing with photographs, whilst the unknown parts of the buildings are reconstructed according to a generic model *of* that type of building, using the existing parts as a frame of reference for placement, measurements, and shape.

---

<sup>75</sup>. Dylla *et al.* 2010.

De Luca and colleagues,<sup>76</sup> as mentioned, guide the shapes of each architectural component model on the basis of its definition. They can do so because the technical vocabulary developed for classical architecture is a highly structured and granular verbal way of representing atomic visual features. For example, column outlines are subdivided into the smallest unit necessary to reproduce them: torus,<sup>77</sup> listel,<sup>78</sup> scotia,<sup>79</sup> etc. (see Figure 4). The generic model thus obtained is subsequently adjusted and registered by the modeller to fit the quantitative data gathered through direct acquisition methods (3D scanning, photography).

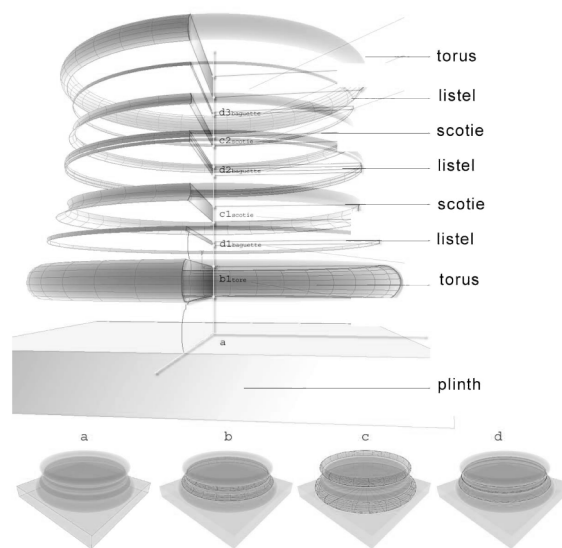

Figure 4. Example of classical architecture column parts (from De Luca *et al.* 2005, p. 3).

Bookbinding studies lack a highly formalized technical terminology that aims at describing each atomic visual feature of a structure.<sup>80</sup> Models *of* describe prototypical instances of structures, and are, therefore, not concerned with specific measurements of an item. Similarly, spatial positioning of components is only

<sup>76.</sup> De Luca *et al.* 2005; De Luca 2013.

<sup>77.</sup> Torus: convex, semi-circular moulding often at the base of columns (Encyclopædia Britannica 1911).

<sup>78.</sup> Listel: A small list or fillet (Oxford English Dictionary 2014b).

<sup>79.</sup> Scotia: concave moulding with a lower edge projecting beyond the top and so used at the base of columns as a transition between two torus mouldings with different diameters (Lewis & Darley 1986).

<sup>80.</sup> See chapter 4.

suggested by the explication of the relationships between items — e.g. A is part of B. All of these problems, it would seem, impede the successful generation of diagrammatic visualization of bookbinding structures, or other material objects given the same procedural constraints, when compared with the formal application of semantic modelling in the examples given above.

Notwithstanding this, models *of* are specifically developed to describe reality as an object of study, and by generalizing and categorizing it allow to compare examples. If this information can be harnessed and transformed into diagrams, these too can be used as visual models *of*.

There is a lot of experience that can be gathered from the examples above, even if the means are different. All of the above-mentioned projects have been successful in their endeavours. However, none has analysed what it is exactly that makes the project a success, what are the minimum requirements for a successful intersemiotic translation from verbal to visual of a material object.

This project aims to generate diagrammatic visualizations, directly from the data included in databases, and not through a second layer of modelling that guides a modeller in the production of diagrams. Also, for bookbindings, there is not a highly structured and granular terminology that can be used in the same way as classical architecture vocabulary. Because of all of these reasons, the experience accrued in the semantic modelling project presented above, would need to be adapted and generalized.

In addition to this, the visualizations for this project are not based on an extra layer of modelling with information specifically selected for the generation of the graphic outputs, and this means that there is a direct link between the data recorded verbally in databases, and the automated diagrams. This way, the diagrams are associated with the object that they represent indirectly and through the description of it in the database. As mentioned in chapter 1, visualizations have been used in a number of fields as verification tools. It is, therefore, interesting to investigate whether this relationship between data and visualizations can be harnessed and the automated diagrams used as data verification tools.

In order to be able to adapt and apply a similar transformation from verbal to visual to another field, such as bookbinding studies, one needs to understand

what kind of information is essential. To generalize and understand the issues linked with an intersemiotic translation from a verbal model *of* a material object such as a binding structure, into a diagrammatic representation, one needs to consider the nature of the two languages involved and of the items to be represented, and also issues linked with human perception and cognition, since the intended user of the diagrams are human beings. Through this kind of analysis, one can advance a general methodology applicable to any material object.

## Summary

Two main categories of modelling activities can be distinguished: modelling *of* and modelling *for*. The former is focussed on discerning the essence of a material object, whilst the latter aims at the generation of a particular entity. The former looks at the general, the latter at the particular.

Verbal to visual automated transformations in the cultural heritage field have generally been based on modelling *for* methods, making use of information on the spatial configuration of the components, their measurements, and their shape. None of these has considered bookbindings and none of these relies on information already recorded within databases. Instead, they develop an extra layer of modelling, and typically gather more data, specifically for the purpose of generating a graphic output. In these projects, qualitative data (verbal input) is often mixed with quantitative data (measurements, scans, or other direct acquisition methods) to solve the problems of indeterminateness found in verbal descriptions. Also, none of these projects has attempted to develop a general methodology to ascertain the minimum amount of information that is required for successful verbal-to-visual transformations for material objects in other fields. It has not been addressed whether it is possible to generate successful transformations based on less specific, but more prototypical information contained in a model *of*, using data already gathered within databases, and whether these visualization could be used as data verification tools.

Transformations based on models *of* need to address the problems of the spatial configuration of the components and their specificity in different ways. To understand how this is possible, the next chapters will investigate the nature of the various entities and processes involved in the project, then to apply these transformations to the field of the study of bookbinding structures.

## Chapter 3. Signs & material objects

*We should, however, recall that our mind can be stimulated by many things other than images — by signs and words, for example, which in no way resemble the things they signify. [...] It is enough that the image resembles its object in a few respects. Indeed the perfection of an image often depends on its not resembling its object as much as it might. You can see this in the case of engravings: consisting simply of a little ink placed here and there on a piece of paper, they represent to us forests, towns, people, and even battles and storms; and although they make us think of countless different qualities in these objects, it is only in respect of shape that there is any real resemblance. And even this resemblance is very imperfect, since engravings represent to us bodies of varying relief and depth on a surface which is entirely flat. Moreover, in accordance with the rules of perspective they often represent circles by ovals better than by other circles, squares by rhombuses better than by other squares, and similarly for other shapes. Thus it often happens that in order to be more perfect as an image and to represent an object better, an engraving ought not to resemble it.*

René Descartes, Discourse IV of *The Dioptrics*, 1637.

At the end of the introductory chapter, reference to the communication cycle for the project was made, highlighting the various entities and processes that come into play. Communication can be defined as the exchange of any kind of message

and of the system of signs of which it is made.<sup>81</sup> Signs then are the basic units of communication. To understand what a sign is, one can begin from a general definition: anything that stands for something else in certain respects.<sup>82</sup> It is through the process of *standing for* that meaning is created.

This chapter looks at the communication process through signs, and how meaning is conceptualized in the human brain. It also investigates the nature of material objects and what is the minimum amount of information needed to communicate their essence.

### 3.1. Signs, signification, and communication

Semiotics, the science of signs, studies signs in processes such as communication, cognition, and linguistics.<sup>83</sup> There are two main traditions of semiotics. One, started by the linguist Ferdinand de Saussure (1857–1913), proposes a *dyadic* notion of signs, whereby every sign consists of two parts: the *signifier*, a sound, word, or image, and the *signified*, the mental concept to which the signifier is related. Whilst Saussure admits that signs can be other than words, his theories are mostly concerned with how meaning is created through words and conventions, arbitrary signs. Another tradition, coming from the investigations of the logician Charles Sanders Peirce (1839–1914), proposes instead a *triadic* theory of sign, with each sign consisting of three parts: a *sign-vehicle*, an *object*, and an *interpretant*.

Saussure's tradition, usually followed by linguistic studies, has been criticized by scholars interested in a wider notion of sign — besides written or oral language — for offering a rather static notion of signs and focussing only on systems of arbitrary signs.<sup>84</sup> Therefore, many semiologists, while acknowledging the fundamental understanding of the structure of signs in Saussure's theories, prefer to turn to Peirce's richer typology of signs, thus allowing for different modes of signification,

---

<sup>81</sup>. Sebeok 1991.

<sup>82</sup>. Hoopes 1991.

<sup>83</sup>. Moriarty 1994.

<sup>84</sup>. Iversen 1986; Bryson 1991; Alpers *et al.* 1996.

not just arbitrary signs.<sup>85</sup> Given the issues of the project at hand, the theories set by Peirce are of interest. However, Saussure's dyadic (signified-signifier) relationships are included in Peirce's categories.

### 3.II. SIGNS

Let us consider briefly the basic concepts of Peirce's triadic theory of signs. A sign consists of three interrelated parts: a sign-vehicle, an object, and an interpretant.<sup>86</sup> Figure 5 shows the relation between the three elements, as customarily schematized as a triangle. The sign-vehicle is the signifying element, or signifier, e.g. a word; the object indicates what is being signified, e.g. the object to which a word attaches; the interpretant, the most significant and distinctive feature of Peirce's theory, is best described as the understanding that one has of the sign/object relation, thus, since the signification is not simply a dyadic sign-object relationship, a sign has a signification only for the fact that is being interpreted: the meaning of a sign is made manifest through the interpretation that it generates in the sign users. Further, a sign is determined by the object it signifies, as the object imposes certain parameters that the sign must follow in order to represent that object, but not every characteristic possessed by an object is relevant to signification and the process of sign determination.<sup>87</sup>

In other words, the object determines the sign by imposing some constraints that the sign ought to meet in order to signify it, and the sign signifies the object only by virtue of certain features possessed by the object; that is to say that the nature of the object itself limits its sign's nature in terms of what is required for successful signification in a selective abstraction<sup>88</sup> process. The sign also determines

---

<sup>85</sup>. Rose 2012.

<sup>86</sup>. Peirce, and many scholars after him, call the three components of a sign: sign, object, and interpretant. This particular nomenclature has the potential of creating confusion for the fact that it appears to be that of the three elements of a sign, one is the sign itself (leading to the misconception that a whole is in fact a part of itself). For this reason, Atkin (Atkin 2010) refers to that element of the sign responsible for signification as the *sign-vehicle*; the same convention is followed here. Other terms used by Peirce for the signifying element are: *representamen*, *representation*, and *ground*.

<sup>87</sup>. Short 2007; Atkin 2010; Burch 2010.

<sup>88</sup>. Greenlee 1973.



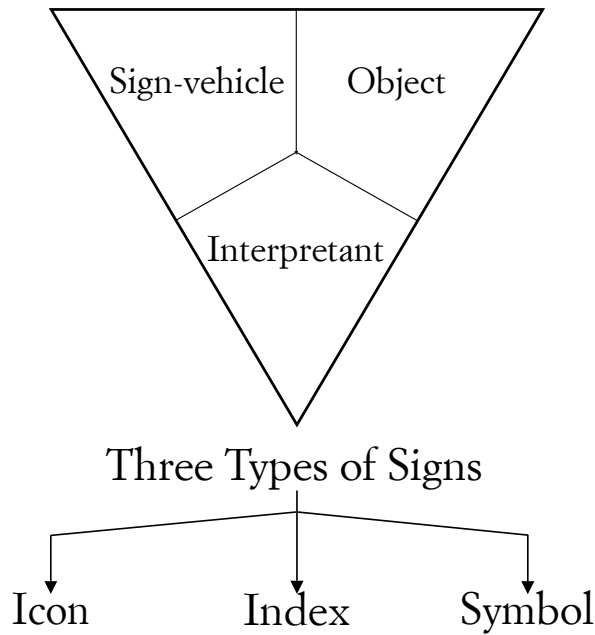

Figure 5. The basic structure of signs and its trichotomous nature according to Peirce. Note that a sign may display a combination of iconic, indexical, and symbolic characteristics.

the interpretant by focusing the attention on some features of the sign/object relationship.<sup>89</sup>

According to Peirce, the object then determines its sign by dictating some constraints for a successful signification. The nature of the requirements of these constraints determines the typology of the sign, and this allows a distinction to be made between three types of sign. When the sign is required to reflect, exhibit, or exemplify qualitative features of the object, i.e. to resemble the object in some respect, Peirce calls this sign an *icon*, e.g. a diagram. If some kind of connection between the sign and the object, be this connection physical or existential, is required, then the sign is an *index* e.g. a footprint, or a rubbing. Finally, if it is required that the sign is connected to its object by means of conventions, or social rules, the sign is a *symbol*, e.g. a word. It should be noted that the three typologies of signs are not and need not be clear-cut and mutually exclusive categories, but rather any sign may display a combination of iconic, indexical, and symbolic characteristics.<sup>90</sup> In addition to these three basic types, semioticians have distin-

<sup>89</sup>. Burks 1949; Short 2007; Atkin 2010; Burch 2010.

<sup>90</sup>. Short 2007; Atkin 2010; Burch 2010.

guished between other kinds of signs. Sebeok<sup>91</sup> lists the species of signs that are found most frequently in the literature; amongst these are *zero signs*, icons, indexes, symbols, and names (or verbal labels).

Sebeok<sup>92</sup> also signals how the receiver of a message inevitably interprets both signs and their context to interpret it. Context, as it will be seen, is of particular importance for iconic signs.

There are two kinds of signs involved in the project at hand: symbols, or even better names, as verbal descriptions use words, names to convey their meaning, and diagrams, which fall under the category of iconic signs. To be more precise, the project's visual sign should be referred to as *hypoicons*, since there are a number of conventional rules in use in drawings of bookbinding structures.<sup>93</sup> Peirce, in fact, defines hypoicons as a particular case of iconic signs in which the likeness to the object is 'aided by conventional rules'.<sup>94</sup>

### 3.1.2. READING AND REMEMBERING ICONIC SIGNS

Iconic signs have sparked a lot of discussion in the field because of the problems that they pose as entities bearing meaning: to read an icon, in fact, unlike written language with letters and words, is not a simple matter of knowing its components.<sup>95</sup> This has significant implications for this project, as the automated transformations will need to generate diagrams, whose meaning is definite and unambiguous.

#### 3.1.2.1. READING MODALITIES OF ICONS

Eco<sup>96</sup> has identified two *reading modalities*<sup>97</sup> of icons — i.e. two different ways in which icons can be read. The border between the two is for the most part fuzzy.

---

<sup>91</sup>. Sebeok 1994.

<sup>92</sup>. Sebeok 1994.

<sup>93</sup>. See chapter 4.

<sup>94</sup>. Peirce 1931-1935/1958: CP 2.276; Peirce 1931-1935/1958: CP 2.279; Peirce 1992-1998: EP 2:273, 1903.

<sup>95</sup>. See Eco 1997 for a summary of the debate on iconicity.

<sup>96</sup>. Eco 1997.

<sup>97</sup>. Eco 1997, p. 336.



Figure 6. Mexican on a bicycle.

Except for a few specific cases, they are not clear-cut modalities, but rather the reading modality can gradually switch from one to the other in the course of an interpretation. The selection of the appropriate reading modality is linked both to the nature of the sign and to its context.

First there is an *alpha modality*.<sup>98</sup> Some signs are characterized by the immediacy of perception. They are interpreted and given some meaning strictly on the basis of their perception. When one can approach a sign and interpret it solely through immediate perception there is an alpha reading modality. For example, in Figure 6, by simple perception and based on our knowledge, one can easily interpret the image as showing a man on a bicycle, and in doing so one reads the image through the alpha modality.

Then there is the *beta modality*.<sup>99</sup> According to this modality one has to assume that what is being perceived is in fact a sign whose function was intentionally that of the communication of a specific meaning: one sees that there is a sign and that such a sign stands for something else. Returning to the man on a bicycle one could notice that the man is wearing a specific hat. The hat could be recognized as being a sombrero, a typical Mexican hat. One could then infer that the image is showing a Mexican on a bicycle. If one then realizes that the image is on the webpage<sup>100</sup> of

---

<sup>98</sup>. Eco 1997, p. 336.

<sup>99</sup>. Eco 1997, p. 336.

<sup>100</sup>. <http://www.amigos.co.uk/Our-Philosophy.aspx> (accessed April 2015).

a chain of Mexican food specialized in home delivery, one could happily conclude that the interpretation was indeed correct.

The same image can then be read according to two modalities in order to get to its intended meaning. However, in the case of the Mexican on a bicycle the beta modality was weak and the reading process oscillated between the two reading modalities. In a scale that goes from strong alpha modality to strong beta modality there are signs that maintaining a high level of detail definition, and are mostly read according to the alpha modality. Then there are other signs, which are highly abstract and whose interpretation is necessarily linked to a beta reading modality. In fact, while still visual signs, their interpretation through the alpha modality would not go much beyond the basic shape information that the perception provides. Let us consider the image in Figure 7. Through simple perceptive interpretation and alpha modality the *doodle*<sup>101</sup> would have very little meaning. The title provides the reading key: ‘A Mexican on a bicycle’. Only when one has given or has guessed the correct interpretative key can one decide that what the figure is showing is a certain object or scene, thus adapting what one is perceiving with what is known.

In generating diagrammatic visualizations for bookbinding descriptions, one needs to be aware of these reading modalities, and efforts should be made in order to provide the necessary information to infer from an icon the desired meaning.

### 3.1.2.2. FORMALIZATION OF HYPOICONS

One aspect of the difference between symbolic signs and iconic signs is that of the reproducibility. One could recreate an exact copy of a sign — e.g. every letter within this text is an exact copy of itself, every letter ‘a’ belonging to the same font is an exact replica of itself — but, for the most part, in everyday life, one deals with replicas — e.g. a letter ‘a’ within one font is understood as signifying the same letter type *a* as any other font, for example this ‘a’, even though they

---

<sup>101</sup>. Doodles are nonsensical pictures containing a few abstract pictorial elements that are very difficult to understand without being given a caption or thematic clue (Nishimoto *et al.* 2010). Roger Price, a famous author of doodle books, defines a doodle as ‘borkley looking sort of drawing that does not make any sense until you know the correct title’ (Price 1976, p. 2).

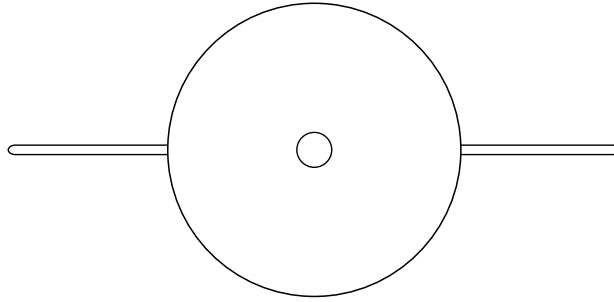

Figure 7. Mexican on a bicycle — as seen from above (after Eco 1997, p.344).

are not exact copies of each other — whereby only the essential characteristics are preserved, the *a-ness* of the letter type *a*, disregarding every other characteristic not perceived as fundamental for the message to be conveyed.<sup>102</sup>

Within signs, one can identify a *type/token ratio* between a particular occurrence of a sign and the class of all occurrences of the sign, between the ‘*Q*’ of a particular font, and the class of the letter *a* in whichever form.<sup>103</sup> Eco<sup>104</sup> further distinguishes between two kinds of these *ratios*: a *ratio facilis* and a *ratio difficilis*. In a *ratio facilis* each occurrence of a type of information is generated and presents itself in accordance to the code of an expression system that has formalized its appearance, and it is thus easily remembered and reproducible. This is the case of words and highly stylized — or symbolic — graphics, like any letter *a*. In the case of a *ratio difficilis*, instead, each occurrence is generated and presents itself in accordance with its own content, either because a pre-formed type does not exist that is available as a code, or because the expressive type (the sign) and the content type (the information to be communicated) coincide. These signs, because of the lack of graphic conventions, are more difficult to reproduce while maintaining them their true meaning. These are typically iconic signs.

There can be two cases of *ratio difficilis*: on the one hand the sign is a precise unit that corresponds to a precise content, it is not too difficult to reproduce and in the long run can be seen as being ruled both by *ratio facilis* and by *ratio difficilis*. On the other hand the sign presents itself as a whole composed of undefined portions of imprecise content.

---

<sup>102</sup>. Eco 1975/2008.

<sup>103</sup>. Sebeok 1994.

<sup>104</sup>. Eco 1975/2008.

What this means is that, even in absence of an established convention, some iconic signs, with time, can become recognisable as discrete units of precise meaning. In chapter 6 it will be shown how endband cross-section diagrams can be read in this manner.

### 3.1.3. VISUAL TEXTS

There is a fundamental issue that has troubled semioticians: while in language one can identify discrete units at every level of investigation — i.e. phonemes,<sup>105</sup> morphemes,<sup>106</sup> textual chains — in visual expressions instead there are units that are dramatically mutable and undefined, with an infinite number of acceptable variants. Even when iconic signs present themselves as discrete units — e.g. two circles can signify a pair of eyes (see Figure 8) — these depend on context, often provided by a set of shapes in a specific range of spatial relations, or by some verbal anchors, like a title for an image. If taken away from their context they lose their meaning: they are forced to be read only through the alpha modality and all that can be inferred is their shape.<sup>107</sup>

Images then, it would seem, need to be regarded as macroscopic blocks of information, within which it is possible to identify pertinent units, but these units are not independent. One can see, understand, and label the legs in the drawing of a table, thus perceiving them as separable discrete units, but if these are indeed separated and presented on their own they would lose their meaning of ‘legs of table’ and would instead be perceived as ‘parallelograms’, a label still correct, but too general to convey the meaning they possessed in context. These units do not possess a fixed distinct value that opposes itself to that of the other units within the system, but rather, their oppositional value and meaning depends on the context.<sup>108</sup>

---

<sup>105</sup>. In linguistics, units of sound in a language that cannot be analysed into smaller linear units and that can distinguish one word from another. (Oxford English Dictionary 2014e).

<sup>106</sup>. In linguistics, minimal and indivisible morphological units that cannot be analysed into smaller units. (Oxford English Dictionary 2014c).

<sup>107</sup>. Eco 1975/2008; Barthes 1978; Polidoro 2008.

<sup>108</sup>. Eco 1975/2008.

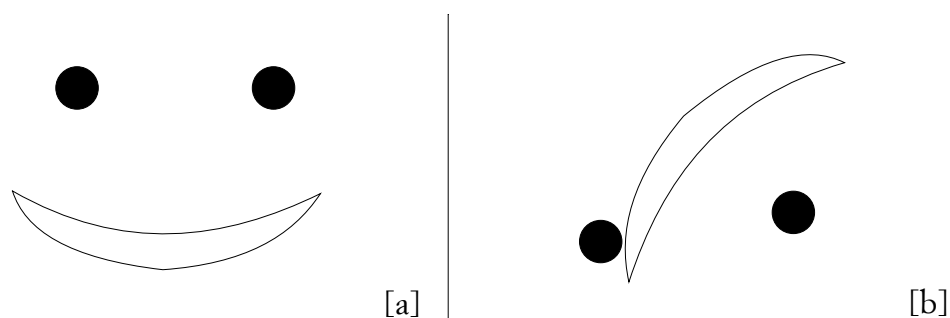

Figure 8. Units in visual language are context dependent: the same elements that are perceived as parts of a smiley face in [a] are not recognized as eyes and mouth in [b].

Saint-Martin<sup>109</sup> introduces the idea of special kind of visual sememe<sup>110</sup> that she calls *coloreme* to indicate the non-discreet semantic units within icons. These entities are ‘continuous and spatialized topological entities, endowed with somewhat fuzzy boundaries’.<sup>111</sup> The continuous and spatialized nature of visual sememes has important consequences for their generation, as it will be seen in chapter 5.

In verbal communication, there are discreet sign units that can be decomposed into smaller pertinent and discreet units taken from within a pre-determinable and finite set dependent on a specific code. In visual communication instead, the sign units are not further analysable into discreet and separable sememes. Images can then be seen as *visual* or *iconic texts* that, instead of depending on a predetermined code, institute themselves an inferential code.<sup>112</sup> Texts are in fact not defined by the presence of linguistic elements, they can rather be defined as portions of reality composed by a number of elements that are combined to produce a coherent meaning.<sup>113</sup>

Images need to be analysed and read as texts, whose meaning, while depending on the information conveyed by the units that compose them, becomes evident only when they are considered as wholes. Unlike word-based texts though, the receiver does not scan the text in a sequential manner, but rather engages in an active search activity, rapidly scanning the entire sign in a synchronic manner, jumping from part to part, looking to recognize some of these parts, thus finally

<sup>109</sup>. Saint-Martin 1990.

<sup>110</sup>. In linguistics, a sememe is the smallest unit of meaning. (Oxford English Dictionary 2014g).

<sup>111</sup>. Saint-Martin 1990 pp. 5-7.

<sup>112</sup>. Eco 1975/2008; Polidoro 2008.

<sup>113</sup>. McKenzie 1999.

obtaining a global understanding of the whole sign. Each new part is understood in relation to the others until the whole sense — or indeed a whole sense — can be inferred. Thus, meaning can be extracted through a process of active vision and interpretation of what is being perceived from major or minor details.<sup>114</sup>

This synchronicity of the information read in visual texts allows to gather in one scan a picture of the whole without having to first understand all of its constituent parts. Diagrams are a more immediate form of information delivery systems than sequential verbal information as they facilitate to grasp in a short time a picture of the whole. In the literature, in fact, images are often described as whole, integrated entities, whose elements are perceived in a simultaneous and synchronous way.<sup>115</sup> As it will be seen in chapter 7, a consequence of the synchronicity and of the immediacy of visual texts is that problems and errors in the data can be immediately perceived. The interdependence of the signs within visual texts is also an important factor that needs to be kept in mind in the generation of automated diagrams, as the appearance of one bookbinding component will depend on that of the other components that come together in a specific diagram.

### **3.2. Multimodal communication**

As seen above, visual information may need to be anchored through verbal labels in order to initiate a reading in *beta modality*. Therefore, introducing verbal information within bookbinding diagrams might be beneficial.

---

<sup>114</sup>. Saint-Martin 1990; Findlay & Gilchrist 2003; Ware 2013.

<sup>115</sup>. Ivins 1953/1969; McLuhan 1964/2001; Goodman 1976; Arnheim 1969; Dondis 1973; Ivins 1973; Mitchell 1980; Snyder 1980; Mitchell 1986; Eco 1993.



### 3.2.I. DUAL-CODING REPRESENTATION

Experiments by cognitive psychologists have investigated the effects of verbal-visual mixed communication. Paivio<sup>116</sup> has brought forward a dual-coding theory according to which the human mind stores information in the brain through two modes of representation: verbally, through what he refers to as *logogens*, and non-verbally, through *imagens*. *Imagens* denote mental representations of visual information. *Logogens* denote mental representation of language information. Learning and behaviour are thus mediated by two independent and interconnected systems: a verbal system that is more logical and abstract that through *logogens* stores information about language (but not of the sounds of the words), and a visual one that through *imagens* stores information on objects, grouping, whole-parts relationships, and spatial information and arrangement. The two systems are said to be independent, as they can work in isolation, and interconnected, as information can be transferred from one system to the other and they can influence each other. Pavio<sup>117</sup> also predicted that dual-coding might facilitate performance. Experimental evidence suggests the correctness of his assumptions: subjects recall twice as much when they are presented information both visually and verbally, than just visually and even more drastically than just verbally.<sup>118</sup> Interestingly, research on memory for complex visual material also demonstrated better recalling for visual input that is immediately followed by verbal descriptions; however, this beneficial effect has only been demonstrated for cases in which the verbal information integrates visual information or when it makes data more salient and distinctive by simplifying and fixating it.<sup>119</sup>

Information presented duo-modally facilitates cognition, but only when the equilibrium between the two modes is maintained. Verbal labels can be used to facilitate memorization of the information conveyed through diagrams, and this in turn facilitates comparison between different exemplars.

---

<sup>116</sup>. Paivio 1971; Paivio 1975; Paivio 1986; Paivio 1991; Paivio 2007. Also Brandimonte & Gerbino 1996; Ware 2013.

<sup>117</sup>. Paivio 1975; Paivio 1986; Paivio 1991.

<sup>118</sup>. Paivio & Csapo 1973; Paivio 1991; Paivio 2007.

<sup>119</sup>. Klatzky *et al.* 1982; Wiseman *et al.* 1985; Paivio 2007; Brandimonte & Gerbino 1996; Gauthier *et al.* 2003; Brown *et al.* 2010.

### 3.2.2. VERBAL RECODING OF AMBIGUOUS VISUAL STIMULI

A famous experiment by Carmichael, Hogan, and Walter<sup>120</sup> adds an important aspect to this discussion. As we have seen, according to the dual-coding theory, the two systems are interconnected and they can influence each other. This can have a profound effect for ambiguous visual percepts. In their experiments, in fact, they showed how a verbal label associated with an ambiguous visual stimulus determined how the stimulus was interpreted and subsequently remembered. The label affects drastically the perceptual interpretation.

Table 1 shows three of the visual stimuli used by Carmichael and colleagues in their experiment (visual stimulus), the verbal labels (label 1 and 2), and the subsequent interpretation (reproduced image 1 and 2). The subjects were presented an ambiguous stimulus, for example two circles connected by a line, and they were told that the stimulus represented one or another object (label 1 and 2), for example eyeglasses or a dumbbell. Subsequently, the interpretation and recall of the information were completely different, depending on and strongly influenced by the different verbal label provided at time of perception (reproduced image 1 or 2). Language can affect and anchor the interpretation of a visual stimulus. The same effect can also be seen when ambiguous visual stimuli are not given in isolation but in context: as in Figure 8, the two circles, when in the right context are read as eyes, otherwise are simply read as circles, but if a label ‘face’ were provided with the picture, with a little effort one could see the circles as the eyes of a somewhat deformed upside-down face.









Rep. image 1	Label 1	Visual stimulus	Label 2	Rep. image 2
	eyeglasses		dumbbell	
	ship's wheel		sun	
	hour glass		table	

Table 1. Samples of ambiguous visual stimuli and their subsequent interpretation as reported by Carmichael *et al.* 1932 (after Cornoldi & Logie 1996, fig. 1.3, p. 15).

<sup>120</sup>. Carmichael *et al.* 1932.

To summarize, there is a beneficial effect in the combination of visual and verbal information. This affects both interpretation, memorization, and subsequent recalling of the information. The ambiguity of visual stimuli can be anchored through verbal labels and/or visuo-spatial context, thus allowing for beta reading modality and subsequent correct interpretation and recalling of the information.

As it will be shown, in the diagrams generated for this project, verbal labels are provided as titles and schematic description texts — i.e. label: value, e.g. attachment: sewn.

### 3.3. Categorization and prototypification

At one time it was commonly thought that the grouping of entities into categories was the effect of arbitrary, cultural-based conventions. However, researchers in linguistic, philosophy, and psychology<sup>121</sup> have exposed the existence of symmetries in classification models across different cultures and languages, linking the phenomenon of categorization to common structures in the perception of the world. This model of common structures is also appropriate for the categorization of material objects and their verbal labels.

It is on the basis of this mental model that we can understand the world around us and to communicate. For material objects, this model is linked to their logical form. The next few sections will expose the formulation of this model.

#### 3.3.I. PROTOTYPES

Rosch<sup>122</sup> argues that categories are not simply logical entities whose members are equally defined by possession of a simple set of features. Rather, many natural categories are structured towards best examples — i.e. prototypes — with non-prototypical members ranging from better to poorer examples. Therefore not all

---

<sup>121</sup>. Rosch 1973; Rosch & Mervis 1975; Rosch *et al.* 1976; Hampton 1981; Lakoff 1987.

<sup>122</sup>. Rosch 1973; Rosch 1975.

members of a category are equivalent, and the best examples can serve as reference points in relation to which the other members of the same category are evaluated. In other words, these best example entities serve as prototypes of the category. The more attributes a member of a category has in common with other members of the same category — and conversely, the less attributes a member of a category has in common with members of another category — the more prototypical this member appears to be. The concept of the prototype functions as a sort of conceptual referential schema against which percepts<sup>123</sup> are compared, and in turn classified.<sup>124</sup>

Psychological studies on human perception have often argued that we define arbitrary forms in terms of a restricted vocabulary of more regular shapes or shape concepts referred to as prototypes. These are represented by clear-cut entities forming a referential base. These perceptual punctuations of a phenomenon are usually associated with linguistic labels. Any shape that perceptually falls between two good examples is seen as deviating or approaching a clear-cut label.<sup>125</sup> For example, Rausch<sup>126</sup> analysed the perception and categorization of an angle growing from 0° to 180°. In his experiments he found that the continuous perception of the growing angle was punctuated by a series of clear-cut percepts to which all other percepts tended. He categorized these as (i) straight line, (ii) arrow, (iii) acute angle tending towards a typical obliqueness of 45°, (iv) right angle, (v) obtuse angle tending towards a typical obliqueness, (vi) bent straight line, no longer perceived as an angle. All other angles are seen as tending towards these clear-cut exemplar percepts, with the range of possible angles tending to the same percept varying: very few will be seen as tending towards the arrow or the bent line, some deviations from the normal will be perceived as almost or bad right angles,<sup>127</sup> with the great majority of angles tending towards the idea of typical obliqueness.

---

<sup>123</sup>. In philosophy and psychology, a percept is an object of perception, or the mental product or result of perceiving something. Oxford English Dictionary 2014d

<sup>124</sup>. Eco 1997.

<sup>125</sup>. Mach 1897/1959; Rausch 1966.

<sup>126</sup>. Rausch 1966.

<sup>127</sup>. Arnheim 1969

This highlights the tendency of the human mind to classify shape percepts as instances within a categorical system in which some features are perceptually fundamental while others are secondary and do not need to be perceptually realized for the percept to be recognized and labelled according to a clear-cut entity reference framework. Because of this tendency, verbal descriptions lack the ability to deliver the specificity, the precise appearance and shape, of objects. However, it is thanks to this labelling system that we can communicate successfully general information about the visual aspects of reality. In practical terms, therefore, when generating diagrammatic visualizations of bookbinding structures from verbal descriptions, the final output will only represent generic information about the appearance of the bookbinding components, but this does not impede the communication of the essence of the elements represented.

### 3.3.2. BASIC LEVEL OF ABSTRACTION

Rosch<sup>128</sup> describes category systems as having both a vertical and a horizontal dimension. Along the vertical dimension one would find the level of abstraction (or inclusiveness) of the category — the greater the inclusiveness of a category within a category system (e.g. a taxonomy) is, the higher the level of abstraction — while the horizontal dimension concerns the segmentation of categories at the same level of abstraction. For example, the entities *kitchen table*, *table*, *furniture*, *thing* vary along the vertical dimension, while the horizontal dimension would include the variations between entities like *table* and *chair*, or *car* and *bus*. Rosch and colleagues<sup>129</sup> have pointed out that along the vertical dimension not all levels are equally useful, but there is a particular level of abstraction – the *basic level* – at which people tend to use a concept. This level is the most appropriate for using, thinking about or naming an object in most situations in which the object occurs. It is also the level at which people tend to functionally interact with an object, as the focus is on the functionality of the category. This level usually happens to be

---

<sup>128</sup>. Rosch & Mervis 1975; Rosch 1978; Garner 1974.

<sup>129</sup>. Rosch *et al.* 1976.

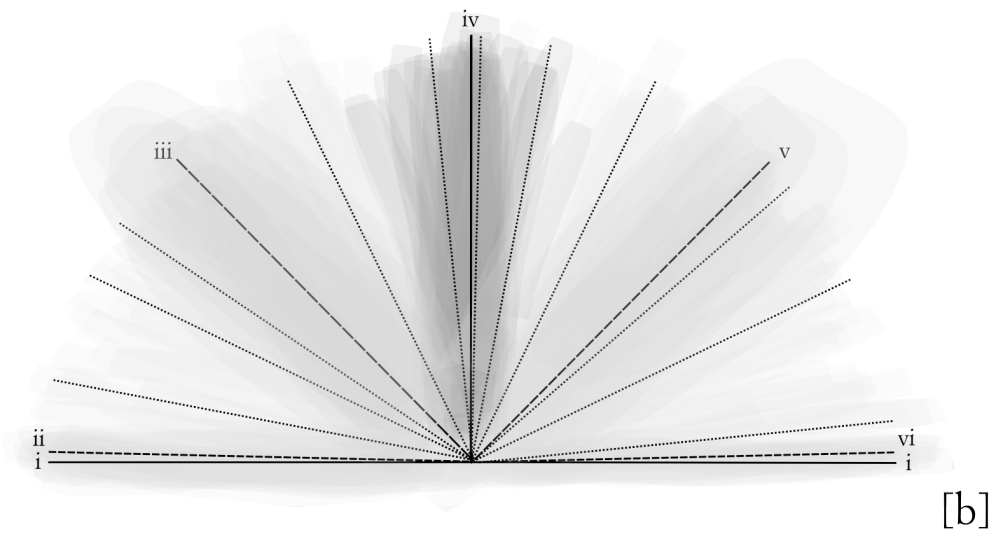
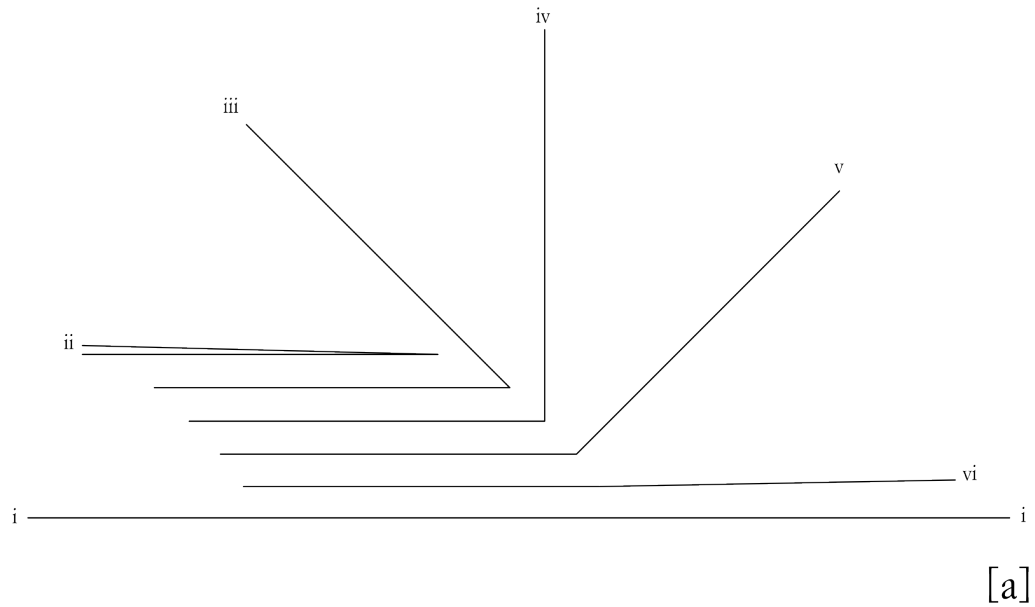

Figure 9. An angle growing from  $0^\circ$  to  $180^\circ$  is seen as (i) a straight line, (ii) an arrow, (iii) an acute angle tending towards a typical obliqueness of  $45^\circ$ , (iv) a right angle, (v) an obtuse angle tending towards a typical obliqueness, and (vi) a bent straight line, no longer perceived as an angle (after Rausch 1966).

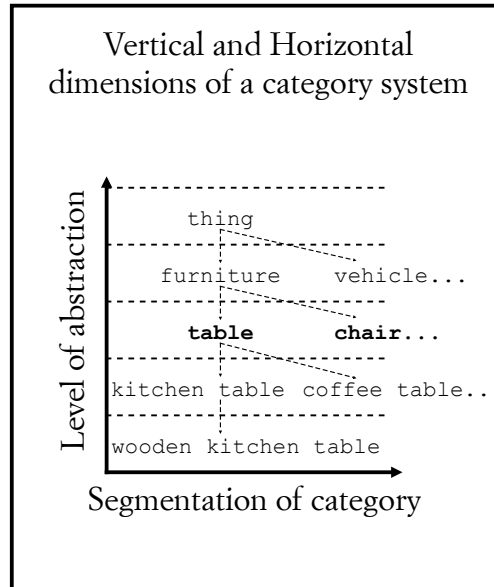

Figure 10. Dimensions of a category systems (after Rosch *et al.* 1976; Rosch 1978; Bobick 1987). In bold the basic level of abstraction.

the middle level of abstraction. The basic level is that of *table*, *car*, *hammer*, as opposed to *furniture*, *vehicle*, *tool*. It is at this level that material objects are most naturally divided into categories. Consider for example the series

furniture>**table**>kitchen table

*furniture* being the superordinate level, *table* being the basic level, and *kitchen table* being the subordinate level. If one ponders which would be the most useful term in the great majority of situations, the answer would have to be *table*, i.e. the middle level of abstraction. Rosch's experiments also suggested that for objects at the basic level it is possible to form a mental image that will resemble the appearance of members of the class as a whole.<sup>130</sup>

Psychological studies on mental imagery<sup>131</sup> have highlighted how mental representations of visual information are seen as possessing structural and spatial characteristics. Every part of an object and its spatial relations are encoded in the mental representation in such a way that they are readily available for thought processing. In addition, most importantly, such spatial and structural information

<sup>130</sup>. Rosch 1978.

<sup>131</sup>. Pylyshyn 1976; Kosslyn 1980; Jolicoeur *et al.* 1984; Cave & Kosslyn 1993; Biederman 1995; Cornoldi & Logie 1996; Kosslyn & Ganis 2010; Pylyshyn 2011; Pitt 2012; Thomas 2013.

gathered through visual perception is not available to language-base thinking.<sup>132</sup> Interestingly, research in neuroscience<sup>133</sup> has confirmed that when we perform tasks that involve mental imaging, the same neural pathways that are activated during perception become active: both actions of seeing a table, and picturing it mentally activate, for the most part, the same visual processing centres in the brain. In turn, the same neural pathways are activated by surrogate stimuli in drawings leading to the possibility of the generation of graphic prototypes.<sup>134</sup>

Jolicoeur and colleagues<sup>135</sup> have introduced notion of an *entry point level* for atypical objects. Very distinctive and atypical exemplars have a semantic entry point into the category at the subordinate level. The entry point is therefore an attribute of specific objects rather than, like the basic level of abstraction, of the category as a whole. It can be argued that the notion of the entry point is applicable also to specific uses of objects and their category. Prototypification at the basic level of a category is typically too inclusive to be useful in the classification of particular kinds of objects, or their structures. Thinking of bookbinding structures for example, a description at the basic level of abstraction would refer to an end-band, a sewing structure, a corner, but would not allow further specification. For the purpose of this project, a more useful level of abstraction and entry point would necessarily be represented by a more subordinate category, thus allowing for a more specific identification, and in turn, as it will be seen, a more useful visualization. If one were to describe the ‘table’ items of a furniture shop, the term *table* would be as generic as *furniture* in usual circumstances, while the terms *kitchen table* or *coffee table* would provide the necessary level of abstraction to allow for successful communication. In the same way, the basic level of abstraction for this project would necessarily need to be less inclusive than usual, as it is at that level that communication on binding structures can be valuable. For simplicity, the basic level of abstraction and the entry point level can be considered as equivalent.

---

<sup>132</sup>. Ware 2013.

<sup>133</sup>. Kosslyn & Thompson 2003.

<sup>134</sup>. Kosslyn *et al.* 1993; Kosslyn & Thompson 2003.

<sup>135</sup>. Jolicoeur *et al.* 1984.



Tversky and Hemenway<sup>136</sup> point out that parts and their configuration are a predominant feature at the basic level. A *chair* includes a *seat*, a *back*, and *legs*; a *knife* is seen in terms of a *handle* and a *blade*. These parts, and their names, refer both to perceptually identifiable segments of an object, and to specialized functions. The prevalence of parthood could be what grants its special status to the basic level. Specifically, knowledge about parts could explain the superior informativeness of entities at the basic level. In addition, different objects at the basic level seem to differ in respect to their parts, while sharing other attributes; whereas different objects belonging to subordinate levels of the same basic level category share parts, but differ in respect to other attributes.

Entities at the basic level are the most general and they have similar and recognizable shapes. They are also the most abstract entities for which a single image can be formed for such a category. The basic level of abstraction is the highest level for which a generalized outline can be identified and which best reflects the redundancies of the category. Thus, a single line drawing can be used to represent the entire category, if it represents the objects at the correct level of abstraction.<sup>137</sup>

Prototypical entities represent their category and convey information on the whole/part relationship and structural configuration of objects. When information about material objects is not presented at the correct level of abstraction, the communication process fails to convey the necessary information. In particular, using descriptive terms at a superordinate level created indeterminateness. This will be explored in more detail in the course of this thesis as it highlights a fundamental issue that needs to be taken into careful consideration when selecting descriptive terms.

---

<sup>136</sup>. Tversky & Hemenway 1984.

<sup>137</sup>. Rosch & Mervis 1975; Rosch *et al.* 1976; Tversky & Hemenway 1984.

### 3.4. Objects: their form and their shape

Signs signify their object in some respect, and iconic signs resemble their object in some respect. Of all the characteristics that material objects possess, some are more important than others for their identification and signification.

In order to be able to produce successful diagrams of bookbinding structures, there are two features of material objects that need particular attention and that should be communicated: form and shape. These are in fact, as it will be seen in the following sections, amongst the most important and fundamental characteristics that define an object both perceptually and conceptually.

#### 3.4.1. THE FORM OF OBJECTS

Material objects are spatial entities that occupy a single specific region of space-time as autonomous forms of organization which can consist of multiple parts.<sup>138</sup>

Each one of these parts is in spatial relation to the others and to the whole object. What needs to be ascertained is whether a system of communication claiming to inform about the specificity of an object should deliver information regarding this structural organization, or whether, the collection of the parts is in fact enough to describe the whole.

Mereology (from the Greek μέρος, ‘part’) is a branch of philosophy and mathematical logic dedicated to the study of the relations between parts and the wholes they form. Its root as a field of investigation can be traced back to the early days of philosophy (the Presocratics, and then Plato, Aristotle, Boethius), then to Leibniz, Kant, Husserl, and the modern ontologists and metaphysicians.<sup>139</sup> Increasingly, mereological studies have been gaining interest in the fields of knowledge representation and database construction.<sup>140</sup>

---

<sup>138</sup>. Saint-Martin 1990; Koslicki 2008.

<sup>139</sup>. Varzi 2014.

<sup>140</sup>. Doerr *et al.* 2001.

### 3.4.II. MATERIAL COMPONENTS AND FORM

In the typical mereological analysis of parts and wholes that came to dominate the scholarship in the field during the 20<sup>th</sup> century, a well-structured whole and a simple heap of its parts arranged in no particular order is the same: under-estimating the role of wholes and concentrating on the parts, an object is simply the sum of its material parts, arranged in any way. This came to be for a number of historical reasons and to answer a number of metaphysical problems,<sup>141</sup> nonetheless, as pointed out by Koslicki,<sup>142</sup> there must be a way to distinguish between a motorcycle in running condition and the sum of its disassembled parts. Some contemporary philosophers<sup>143</sup> propose to re-accept in the discourse on parthood and wholes, the Aristotelian notion of *form*, and argue that material objects can be regarded as *structured wholes*, to which identity is fundamental, not only that all parts are accounted for, but also that these parts exhibit a certain configuration, or arrangement. Therefore, enumerating the parts a complex object is not enough to describe its essence.

Any communication about material objects should be able to communicate both the range and type of their material components as well as their configuration. In the next chapter, examples of descriptions of bookbinding structures as material objects will be presented, and it will be seen how not being able to communicate the form of objects poses important problems.

### 3.4.II.2. LOGICAL FORM AND EXPRESSION

In addition to form, in order to describe an object, one also needs to be able to refer to its essence. In other words, to communicate an object table, in such a way that the concept is applicable to any table, there needs to be a way to define an idea of *table-ness* capable of prescribing what components could come together to make a table, and in which spatial arrangements, i.e. a conceptual categorization of the prototypical instance of table. This abstract idea of the objects would

---

<sup>141</sup>. Simons 1987; Albertazzi 1999.

<sup>142</sup>. Koslicki 2008.

<sup>143</sup>. Fine 1999; Harte 2002; Johnson 1994; Koslicki 2007; Koslicki 2008.

function like a model *of* it, by prescribing which components are necessary or possible for a given object, and in which relationships these can stand. In philosophical terms, this abstract entity is referred to as *logical form*.<sup>144</sup>

Material objects, therefore, possess an abstract form that determines all possible configurations, a sort of *recipe* for how to build objects of a particular kind *K*; while their material components can be thought of as the ingredients that are called for in the recipe. Each kind *K* has associated with it a set of requirements (the recipe) specifying the range, configuration — and sometimes the number — of material components eligible to compose an object of that particular kind *K*. The logical form makes available positions for the material components to occupy, provided that the occupants satisfy the type restrictions imposed on the positions in question. As a consequence, objects exhibit a particular configuration imposed on them by the logical form. The logical form contributes to two sorts of constraints on its content: (i) constraints concerning the *types* of components; (ii) constraints concerning the topological or geometrical configuration.<sup>145</sup>

To communicate descriptions of different instances of the same kind of material object — e.g. different endleaf structures — one must account for the various material components and for the different ways in which these can stand in relations to one another. Also, in order to be able to describe any instance of the same reality and still make sense, the descriptions must all have something in common, something that corresponds to the logical form of the kind of material objects. Wittgenstein<sup>146</sup> calls *expression* what they have in common and defines all propositions<sup>147</sup> having the same expression in common as belonging to the same class of propositions: this expression is what is constant within the class of propositions,

---

<sup>144</sup>. Pietroski 2014. Of particular interest is the reference to the logical form by Wittgenstein in his *Tractatus Logico-Philosophicus* (Wittgenstein 1922/2012). In accordance with a more recent reading of Wittgenstein's work that replaces the traditional logistic interpretation with one more metaphysical, or physicalist, (Nordmann 2002) and considering the engineering background of the philosopher, (Hamilton 2001b; Hamilton 2002; Hamilton 2012) Wittgenstein's investigations on the relationship between language and the world can be scaled down from the general to the practical issues of the verbal communication of material objects.

<sup>145</sup>. Wittgenstein 1922/2012T: 2.0232; T: 2.0233; T: 2.02331; T: 2.024; T: 2.025; Koslicki 2008; Pietroski 2014.

<sup>146</sup>. Wittgenstein 1922/2012T: 3.31; T: 3.311; T: 3.312; T: 3.313.

<sup>147</sup>. Proposition: in logic, statement which is capable of truth or falsity (Oxford English Dictionary 2014f).

whilst everything else can vary. The expression acts as a recipe of the material object through which all different propositions can be generated. These important concepts will be discussed more in detail in chapter 5.

Both the logical form and the expression then act as a general prescriptive schema for the material object. Logical form is inherent in the conception of material objects, or in the model of the object in our mind. The expression instead is the reference to the logical form that can be found in the descriptions. For example, the expression is embodied in the descriptive schema of databases as it prescribes what variables are possible for a certain object.

In other words, the expression is the model *of* the class of objects that need to be described, and the logical form is that essence of the object that the model *of* strives to capture.

As it will be covered in the following chapters, the lack of a reference to the logical form has critical consequences for the efficacy of a bookbinding description.

### 3.4.2. THE SHAPE OF OBJECTS

Another concept and percept that is essential for the specificity of material objects, and thus for their communication, for the fact that it allows us to distinguish between different instances, is their shape. If compared with other characteristics of objects — e.g. depth, motion, speed, colour, etc. — shape is exceptional. Many objects can share the same colour, or measurements, whereas, the shape of an object is only shared by objects belonging to the same category: an apple can be red, yellow, or green, or any other colour one can think of, just as much as a car can be characterized by the same colours; no two apples are exactly identical, and there are many different kinds of cars, but still the human brain has no trouble identifying an apple as an apple and a car as a car. The only constant, the only perceptual property sufficiently complex and unique to allow for an object to be identified unambiguously, seems to be the general shape of the object, and in particular its prototypical nature.<sup>148</sup>

---

<sup>148</sup>. Pizlo 2008.

### 3.4.2.I. THE NATURE OF SHAPE

Defining what shape is can be difficult. Pizlo<sup>149</sup> proposes a working definition:

*Those geometrical characteristics of a specific three-dimensional object that makes it possible to perceive the object veridically from many different viewing directions, that is, to perceive it as it actually is in the world 'out there'.*

Shape is both structured and complex, and this prevents shape ambiguity and having to rely on the context of the percept for its recognition.<sup>150</sup> This last point does not contradict what exposed on page 38 when it was stated that the perception of the two circles as a pair of eyes depends on the context. In that case what depends on the context is the perception of what the two circles symbolize, not the perception of their shape. In fact, in Figure 8[b] the two circles are still clearly perceived as two dots or circles, what changes and depends on the context is the label of the meaning attached to them. In other words, the right context is what allows to read the image in beta modality, but it is not necessary for it to be read in alpha modality.

Shape is structured in the sense that there can be some invariants and *a priori* constraints, such as symmetry, planarity, compactness, that when applied to the two dimensional projection on the retina help in reconstructing the three-dimensional shape of an object: shape recognition does not depend solely on the physical perception as much as, for example, colour perception does. Shape is complex because it can be described along a large number of dimensions, and its complexity is almost never eliminated by the perspective projection onto the retina. To change one shape into another an infinite number of points would have to be moved.<sup>151</sup>

The general shape of an object is an essential component for its identification, and therefore any communication of a material object should convey shape information, at least in its prototypical form.

---

<sup>149</sup>. Pizlo 2008, p. 1.

<sup>150</sup>. Pizlo 2008.

<sup>151</sup>. Pizlo 2008.

### 3.4.2.2. REGULARITIES FOR THE PROTOTYPIFICATION OF SHAPE

Research in Gestalt psychology<sup>152</sup> has shown that arbitrary shapes are seen in terms of more symmetrical versions of themselves. Some forms are visually perceived as tending towards other more regular shapes to which they are seen as similar or equivalent. Some features were found to be more important for the general impression than others as even slight changes of these result in noticeable effects on similarity, while others can be substantially changed without affecting the general impression. This special characteristic is usually referred to with the German words *Prägnanz* — i.e. singularity, or meaningfulness, pithiness — and these particular features are called *prägnant* — i.e. a singular, meaningful, special value of a trait or parameter.<sup>153</sup>

Goldmeier<sup>154</sup> reports on the perceived similarity amongst shapes. Amongst the many various values that a geometrical variable — e.g. parameters, measurements, relationships — can assume in a figure, the few *prägnant* ones are psychologically singled out and phenomenally realized. For non-*prägnant* characteristics instead, particular values are not realized as such, and ranges of different values will result in the same phenomenal experience.<sup>155</sup> From the results of his experiments Goldmeier delineates the general principle that the basis of similarity is the conservation of *prägnant* values of geometrical parameters, the conservation of symmetry being of particular importance. Symmetry is counted amongst the *a priori* constraints for shape recognition by Pizlo.<sup>156</sup>

In addition, symmetry and other regularities in a perceived object may allow to reduce the amount of information that needs to be collected and stored about that perception. Regularities, allowing for simplification, in fact, are capable of representing more of an image than arbitrary or irregular features.<sup>157</sup>

---

<sup>152</sup>. Koffka 1935.

<sup>153</sup>. Palmer 1999; Sternberg & Mio 2009.

<sup>154</sup>. Goldmeier 1972.

<sup>155</sup>. Arnheim 1969.

<sup>156</sup>. Pizlo 2008.

<sup>157</sup>. Attneave 1954; Barlow & Reeves 1979; Feldman 1997; Feldman 2000.

Symmetry allows a figure to be perceived and coded abstractly and economically. Simplification by regularization, and in particular symmetrization, is at the core of shape perception and conception.

The diagrams for this project require that the shape drawn be recognizable, but also prototypical as they derive from verbal labels. This calls for highly symmetrical shapes. Let us consider for example the diagram of a stirrup ring, a Greek-Byzantine clasp in the form of an ornate ring with a flat slot below it to take the strap,<sup>158</sup> in Figure 11. The diagram does not exhibit any of the irregularities of the example in the photograph, but it is still recognizable as belonging to the same class of objects.

#### 3.4.2.3. LINE DRAWINGS

Prototypical shapes can be generated using two processes: (i) one of regularization that preserves all *prägnant* features; and (ii) one of simplification that only keeps the essential shape features, without affecting their perception.

Gestalt psychologists<sup>159</sup> have studied the perceptual phenomenon by which an object is distinguishable from the background and refer to the dominant shape as *figure* and to the background as *ground*; the phenomenon is referred to as figure-ground organization. The figure is seen as having a closed contour and a shape, while the ground seems shapeless and as extending behind the figure. Figure-ground organization is an essential step in our perception of surfaces, shapes and objects.<sup>160</sup>

Figure-ground organization and the perception of shapes based on their contour against a background is rooted into the human perception system and we perceive, reproduce, and communicate percepts solely based on their contour. Lines, in line drawings, act as surrogate stimuli for the visual contours of the depicted objects. There is strong evidence<sup>161</sup> suggesting that the identification of lines with

---

<sup>158</sup>. Ligatus 2013.

<sup>159</sup>. Rubin 1915.

<sup>160</sup>. Pizlo 2008.

<sup>161</sup>. Dehaene 2009; Pinker 1990; Sayim & Cavanagh 2011; Pettitt & Pike 2007; Cook 2013; Halverson 1992; McKie 2012; Sayim & Cavanagh 2011; Cook 2013; Walther *et al.* 2011; Hochberg & Brooks 1962; Kennedy 1974; Kennedy & Ross 1975; Kennedy 1977; Halverson 1992.



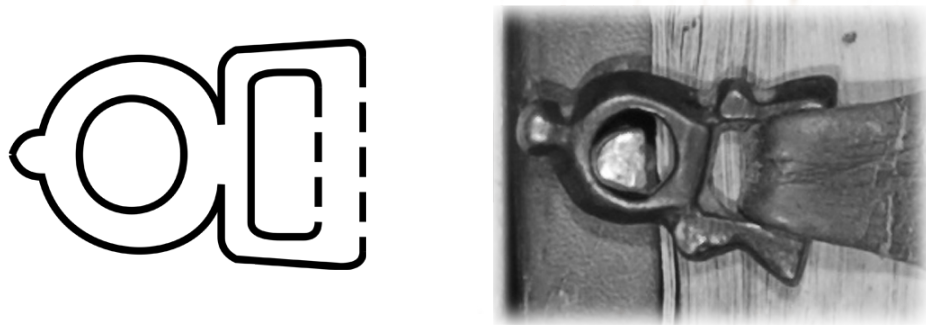

Figure 11. Comparison between a stirrup ring shape and its prototypified diagram. The diagram is generated as part of this project; the photograph is taken from the images collected during the survey of the printed books in the Library of the Monastery of St Catherine on Mount Sinai, Vol. 4077.2841 $\alpha$  (see §4.2.4, §6.1.4).

objects' contours is an innate function of normal human vision, not linked to any social or representational convention, that occurs both cross-culturally and irrespectively of the level of development of the subjects. Line drawings seem to harvest a particular feature of visual perception that is hard-wired into the human perceptual system and can be therefore exploited as an international feature of visual communication.

To depict something strictly by its outline is to simplify, reduce its visual information to the bare necessities: complex optical arrays are transformed to simple lines, and the linear depiction is limited to just the salient features that make the object recognizable. The figure is reduced and simplified, stripped of all non-strictly essential information, through an abstraction process that selects only those features deemed as distinguishing. Outline drawings can be considered as prototypical instances of the classes that they represent.<sup>162</sup>

Biederman and Ju<sup>163</sup> have demonstrated that an object depicted as a simple line drawing can be recognized as quickly and accurately as high-resolution photographs that preserve the object's details, surface texture, and colour. This phenomenon has been more recently researched by psychologists and computer scientists at Stanford University, Ohio State University and the University of Illinois

---

<sup>162</sup>. Halverson 1992.

<sup>163</sup>. Biederman & Ju 1988.

at Urbana–Champaign.<sup>164</sup> The researchers concluded that the features preserved in line drawings are sufficient for the categorization of natural scenes, and the same features are most likely used in categorizing both line drawings and photographs.

Line drawings exhibit, therefore, the minimum amount of information necessary for shape recognition, and are useful communication tools. In the next chapter, it will be seen how line drawings of bookbinding structures can successfully communicate information by visual means.

#### 3.4.2.4. PERCEPTUAL BIASES

Shape prototypification by process of simplification, regularization, symmetrization, and preservation of other *prägnant* features is sufficient for the generation of functional graphical prototypes. However, one should also make sure that such graphic prototypes preserve and communicate in a psychologically sound manner the composition of the object represented along with its form, and the spatial relations amongst its material components. For this one might need to rely on exaggeration of some features and accurate but imprecise spatial relations for immediacy sake.

There is psychological evidence of systematic differences between perceptual displays and their mental representations.<sup>165</sup> Locations and precise measurements are not remembered absolutely by humans as there is not a coordinate system hard-wired in our eyes or brain; rather they are indexed schematically and approximately. Memory for locations and spatial relations is relative. Relative to other elements at the same level of analysis, or to a frame of reference on a higher level of analysis.<sup>166</sup> For these reasons, Tversky<sup>167</sup> suggests that the design of effective graphic representations should ensure that (i) content and form of the visualization correspond to those of the desired mental representation and (ii) are readily and

---

<sup>164</sup>. Walther *et al.* 2011; Shen & Walther 2012.

<sup>165</sup>. Tversky 1991; Schiano & Tversky 1992; Tversky 1997; Tversky 2006; Tversky 2007.

<sup>166</sup>. Tversky 1997; Tversky 2005a.

<sup>167</sup>. Tversky 2006.

correctly perceived and understood, complying with what she refers to as the (i) *principles of congruity* and (ii) *apprehension*.

Naturalism in the diagrams might then actually not be advisable for a successful communication.

## Summary

This project deals with three different entities — objects, words, and images. Information about objects has to be able to be communicated to a human receiver through three processes: perception, communication, and automated transformation. In particular, information has to be able to reach its final destination, while undergoing the transformation process from a verbal communication system to a visual one. Verbal and visual communication systems are quite different, but can work in tandem, complementing each other.

Diagrammatic visualizations can undergo a process of simplification and abstraction from reality, being reduced to the essential shape and form, and still be read and recognized by a human mind as the object that they represent. In fact, it is through the regularities and generalities of shape that an object's appearance is understood and conceptualized, and thus not seen merely as a particular and specific entity.

A way to ensure memory, reproducibility, and usability of graphic prototypes, is to reduce the amount of information to the minimum essential for shape communication, while guaranteeing redundancy of information, so that it can be 'compressed' in our brain's memory, and in turn easily 'decompressed' at will. Line drawings are sufficiently simple and, at the same time, complex enough to preserve shape constancy and object identification, to be successfully used in the generation of graphic prototypes. Entities at the basic level of abstraction have a recognizable generalized outline shape that best reflects the redundancies of the category they come to represent. Further, object recognition from outlines is universal and innate amongst humans. Therefore, simplified line drawings are

sufficient for the communication of material objects, bookbinding structures included.

Vision is not a mechanical and passive system, but rather percepts are psychologically realized and referentially utilized in different degrees of accuracy, with some features being strongly more psychologically salient than others.

Verbal labels can anchor the ambiguity of visual information, and can serve as referential punctuations in the fluidity of visual percepts, thus providing a clear-cut structure to an otherwise essentially analogical system.

This chapter has considered a number of considerations on the nature of the entities and processes involved in this project and has outlined a theoretical framework onto which a method could develop. The next chapter will review the ways in which bookbinding structures have been described, both verbally and visually. Different kinds of verbal descriptions of bookbinding structures will be covered, and these will be then analysed to see which kind could be best used for appropriate communication and even more so for a successful intersemiotic translation.

# Chapter 4. Bookbinding descriptions

*Like men, books have a soul and body. With the soul, or literary portion, we have nothing to do at present; the body, which is the outer frame or covering, and without which the inner would be unusable, is the special work of the binder. He, so to speak, begets it; he determines its form and adornment, he doctors it in disease and decay, and, not unseldom, dissects it after death.*

William Blades, *The enemies of books*, 1902, p. 96.

Traditionally, books are not considered as susceptible to archaeological treatment as most are still living tools kept in libraries to be used, and they are not secluded objects kept in museum collections as examples of earlier times. It is true that some books are indeed treated as museum objects, but the prime function of the great majority of them is their service as tools, as useful objects.<sup>168</sup>

## 4.1. Books as artefacts

The book, studied as an object, holds a wealth of information beyond its textual content. Bindings are a prominent part of the artefact book. Books were often bound in accordance to the choices made by their owner, and bookbindings can therefore reflect financial status or the intended use of a book. From the study of bookbindings it is often possible to deduce information about where and when

---

<sup>168</sup>. Adams & Barker 1993.

a book was first used, even when such information is not offered by the content itself.<sup>169</sup>

One of the main problems faced by scholars of the history of bookbinding is that the discipline is young, lacking a well-established vocabulary and a stable description system. This is especially true for research on historical bookbinding structures.<sup>170</sup> In 1945, Goldschmidt referred to the discipline as a ‘humble auxiliary [one], rather childish to some, attractive to others, not entirely useless and undoubtedly innocuous.’<sup>171</sup> Despite such disparagement, a great number of fine and valuable scholarly studies were pursued in the 20<sup>th</sup> century, spanning the mainly aesthetic interests of the Arts and Crafts Movement towards the more scholarly-approach of bibliography.<sup>172</sup>

#### 4.1.1. BINDING STRUCTURES AND DECORATION

The first role of a binding was — and still is — that of protecting the text, but because of the primacy of its impact on the eye, it soon was instilled with and reflected an additional function, that of indicator of social status through decoration and preciousness of covering materials. For the historian of bookbindings there are two levels of research, one more internal to the object, looking at the structure and the materials used to construct a binding, and another focused on externally visible elements such as the cover and overall appearance of the book, i.e. the material employed in covering the book and its decoration. The study of structure and decoration can uncover the reception, and function of books, as well as help establishing the date, provenance and status of a book.<sup>173</sup> Interesting is, for example, the identification of the Turbutt Shakespeare as the original Bodleian copy of the First Folio solely by its (rather plain) binding,<sup>174</sup> or, more recently, the use of the

---

<sup>169</sup>. Pickwoad 2012; Velios & Pickwoad 2012.

<sup>170</sup>. Szirmai 1999.

<sup>171</sup>. Goldschmidt 1945, p. 175.

<sup>172</sup>. Foot 2004.

<sup>173</sup>. Adams & Barker 1993; Pickwoad 2011a.

<sup>174</sup>. Madan *et al.* 1905.

evidence from the bookbinding of the New York copy of Galileo's *Sidereus Nuncius* (SNML) to confirm its forgery.<sup>175</sup> Bookbinding structures and decoration should therefore not concern exclusively the bookbinding historian, but also historians involved in the history of the book, who should take a holistic approach to the object of their research.<sup>176</sup>

Goldschmidt,<sup>177</sup> in 1928, referred to the considerable amount of literature on bookbinding already in existence by that time, and to the fact that the state of knowledge on bookbinding, in spite of the great amount of literature, was still so imperfect, that it seemed impossible to give a coherent history of the binding of books. He pointed out that 'far fewer people [could] give a reasoned opinion on the country of origin and the approximate date of an old bookbinding, than a piece of pottery or furniture.' More than eighty years later, the situation has not changed much. With time, the discipline has evolved and accrued knowledge on bookbinding decoration and historical bookbinding structures.

#### 4.1.1.1. THE EVOLUTION OF BOOKBINDING STUDIES

There are two levels of research for books as artefacts: one more internal to the object, looking at the structure and the materials used to construct a binding, and another focused on externally visible elements such as the cover and overall appearance of the book, i.e. the material employed in covering the book and its decoration. As well noted by Adams and Barker<sup>178</sup> 'structure and decoration are basic factors in understanding reception, function, influence and survival of books'.<sup>179</sup>

When scholars first became interested in the bindings of books and started studying them as artefacts, they addressed their interests towards an art history approach, focussing their attention on exterior, aesthetic elements, such as binding decoration, and the idea of 'styles', to the extent that for the first half of the 20th

---

<sup>175</sup>. Pickwood 2014b.

<sup>176</sup>. McKitterick 2007.

<sup>177</sup>. Goldschmidt 1928, p. 112.

<sup>178</sup>. Adams & Barker 1993, p.21.

<sup>179</sup>. See also McKitterick 2007.

century, the history of bookbinding was virtually synonymous with the history of bookbinding decoration.<sup>180</sup> Decorative elements, and the specific tools used to create them, have been analysed, compared, and identified to hypothesize the links between specific tools and specific workshops, and subsequently, of distinct, individual binders. The consideration of decorating tools from a purely utilitarian point of view as clues to reconstruct parts of the history of an artefact, have proved fruitful and have been central to the work of the majority of scholars interested in the field. Just in the same way as the study of art history can either be based upon the notion of styles, or that of historical sequence and continuous change over time, sporadically in the early twentieth century and, more frequently during the last thirty to forty years, a new interest in a holistic study of the whole bound book flourished, encompassing the materials employed and its structural features, extending the research beyond the study of decoration.<sup>181</sup>

The artefact book is a complex object constituted of multiple components (e.g. gatherings, textblock, binding structure, covering, decoration, metal furniture, and so forth) that, when considered in its totality, proves of invaluable historical interest. If subdivided into individual elements, the study of the book loses much of its meaning. So, while the study of decoration is useful, it should not be considered merely on its own.<sup>182</sup>

Furthermore, the great majority of books have little or no decoration and their study has to be based upon that of their structures. It has been estimated that the extensively expensive bindings that are often the sole objects of study of bookbinding history constitute only a very small minority — perhaps no more than one per cent — of the entire corpus of bookbindings ever produced.<sup>183</sup>

The artefacts are of course the principal objects of the above-mentioned studies, but especially for the very early periods of the history of the codex there are but a scarce number of exemplars. It has been estimated that for Coptic, Anglo-Saxon, and early medieval bindings we are left with no more than 0.01% of the probably

---

<sup>180</sup>. Foot 1993.

<sup>181</sup>. Pollard 1956; Pollard & Potter 1984; Foot 1993; Foot 2004.

<sup>182</sup>. Clarkson 1978.

<sup>183</sup>. Pickwood 2011b.



total number of items produced, having lost any evidence for the rest.<sup>184</sup> For this reason, scholars have to integrate into their research evidence other than what can be directly observed today. For instance, there are a small number of written accounts put together by binders and other observers, varying from simple sets of instructions and *aides-mémoires*, to accurate trade literature in the form of bookbinding manuals describing the processes involved. Although occasionally rather accurate and explicit, these written accounts more often than not are lacking in details and sometimes almost incomprehensible, as for the most describe the techniques just by means of words; nevertheless, they are noteworthy and useful to the historian. Pollard and Potter<sup>185</sup> have traced written evidence of bookbinding as a craft back to the sixth-century CE<sup>186</sup> and the first known detailed description of a bookbinding process comes from a text written in the tenth century by an Islamic binder.<sup>187</sup> In the West, apart from the drawings contained in the frontispiece of a twelfth-century manuscript (Bamberg, Staatsbibliothek, Msc. Patr. 5) showing some bookbinding operations, there are not records of detailed bookbinding instructions earlier than the beginning of the seventeenth century. Although these are comparatively recent, they still provide insight into the techniques adopted by earlier bookbinders as, like all trades, bookbinding is conservative, and binding techniques did not change much up to the nineteenth century.<sup>188</sup>

<sup>184</sup>. Pollard & Potter 1984; Szirmai 1999; Foot 2004.

<sup>185</sup>. Pickwoad 2011b.

<sup>186</sup>. *His etiam addidimus in codicibus cooperiendis doctos artifices, ut litterarum sacrarum pulchritudinem facies desuper decora vestiret, exemplum illud Dominicae figurationis ex aliqua parte forsitan imitantes, qui eos quos ad cenam aestimat imitandos in gloria caelestis convivii stolis nuptialibus operuit. quibus multiplices species facturarum in uno codice depictas, ni fallor, decenter expressimus, ut qualem maluerit studiosus tegumenti formam ipse sibi possit elegere.* ‘Further, we have added to the scribes skilful craftsmen, so that a beautiful external form may cover the beauty of the Sacred Scriptures, somehow following maybe the famous example of the Lord’s parable, who covered with nuptial gowns those who he wanted to invite to the banquet in the glory of the heavens. For the bookbinders, if I’m not mistaken, we have conveniently exhibited in one book many styles of binding descriptions, so that one can choose for himself the sort of binding he prefers.’ In Cassiodorus Senator, *De institutione divinarum litterarum*, Liber I, XXX, 3, (c.550 CE). Author’s translation. (Cassiodorus 1961).

<sup>187</sup>. Abū Ja’far al-Nahhās’s treatise *Craft of the Scribes* providing a number of instructions for bookbinders was included in the eleventh-century work by Tamin ibn Al Mu’izz ibn Bādīs, *Book of the Staff of the Scribes and Implements of the Discerning with description of the line, the pens, soot inks, l q, gall inks, dyeing, and details of bookbinding*, which describes in its final chapter, *On the art of binding books in leather and the use of all its tools until it is finished by the bookbinder, tools and techniques.* (Levey 1962; Bosch *et al.* 1981; Pollard & Potter 1984; Breslauer 1986; Foot 1993).

<sup>188</sup>. Pollard & Potter 1984; Breslauer 1986.

Quite a few references have been discovered both in manuscripts and in printed books, but it should be noted that workshop manuals – perhaps the most useful of the written information on bookbinding one could hope to find – only survive by accident, as they are generally used until they literally fall to pieces and are then thrown away. Important information can luckily, sometimes be gathered from written accounts as information is transmitted from master to apprentice. As with any other craft, bookbinding is normally learned and passed on from master to apprentice by means of trials and practical demonstrations rather than from books or other documents. In fact, a careful examination of the literature on bookbinding gathered throughout the centuries shows how only about ten per cent of it actually covers binding techniques and structures in enough detail to be regarded as truly useful to the bookbinding historian.<sup>189</sup>

Other significant sources of information on bookbindings – on their appearance, internal structure or the way they function - can be derived from artistic sources found in paintings and sculptures, when these are examined with a critical and proficient eye that discerns reality from artistic interpretation. There are examples of artists who would merge characteristics of different structures in one item, thus inventing fictitious books. In most cases, however, one has to turn to extant books.<sup>190</sup>

As noted above, the study and description of the structures and of the materials employed is a new approach to the study of the history of the book that has appeared consistently only during the last few decades. Scholars have begun to focus their attention on the materials that constitute a binding, and the techniques employed to create it, observing the elements that make up a binding structure, or lacking the original binding, the traces that remain. Roger Powell (1896-1990) and Sydney Cockerell (1906-1987) deserve special consideration. Drawing from the experience of their master, Douglas Bennett Cockerell (1870-1945), they created a new approach to book conservation that they then passed on to their apprentices, thus not only fundamentally influencing the evolution of the modern discipline of book conservation, but also subsequently that of the archaeology of the book.

---

<sup>189</sup>. Pollard & Potter 1984; Breslauer 1986; Schmidt-Künsemüller 1987; Szirmai 1999.

<sup>190</sup>. Pickwoad 2008.

Their legacy came to be commonly known as the Powell-Cockerell School.<sup>191</sup> Their interest in the techniques and workmanship of binders of the past, the materials used, the morphological and decorative characteristics of books, the circumstances in which they were commissioned, and the uses of these books, were all passed on to new generations of apprentices and book conservators.<sup>192</sup>

As a result, considering books not just as supports for text, but rather as complex objects, whose study can contribute to research efforts in cultural history, a new approach was established. They developed a prototype for a descriptive methodology of binding structures that is now shared by those currently interested in the archaeology of the book; this involves careful description of materials, techniques and structures, recording of the physical characteristics of the artefacts examined and statistical analyses of such information as well as illustrations, diagrams and photographs.

In analysing the various structures that have been employed in bookbindings over time, it becomes clear that, although there is indeed a limited number of basic structures, the variations of the details of the different components seem endless. There are three main reasons accountable for this variety: firstly, the fact that the processes evolved and were adjusted over time; secondly, different solutions were devised for similar problems and different materials were employed in different geographic locations; thirdly, various workshops had their own special techniques taught as trade secrets.<sup>193</sup> From these, in turn, one can deduce, for example, information about where and when a book was first used, its financial status, or its intended use.<sup>194</sup>

#### 4.1.2. TERMINOLOGY

With the ever growing interest in a holistic approach to the study of the books as artefacts, scholars have focused their attention on the description of binding

---

<sup>191</sup>. Petherbridge 1987, p. 5.

<sup>192</sup>. Sharpe 1996.

<sup>193</sup>. Pickwoad 1995; Foot 2004.

<sup>194</sup>. Pickwoad 2011a; Pickwoad 2012.

structures, materials and techniques. But given the young age of the discipline, and the complexity of some structures, an agreed and generally understood vocabulary is lacking. Despite the publication of a number of technical glossaries,<sup>195</sup> bookbinding has suffered historically from a lack of explicit and widely accepted and understood terminology for materials and structures. Many terms have been used to describe similar, though nevertheless significantly varied structures of different provenance and age. The existing terms are usually derived from trade terminology and dealers in antiquarian books or bibliographers. In addition, many scholars have developed their own specific lexicon of terms to describe bindings.<sup>196</sup> There are terms that are too vague and open to different interpretations, with terms referring to multiple structures, or multiple entities being referred to by the same name. In addition, binding traditions in different countries have developed many different practices, to the point that often there is not an equivalent or precise term for certain structural details across different languages. Also, many binding components have never been verbally labelled at all.

Another problem is that many structures need to be described at the component level, as one structure that could be generally labelled with one term — e.g. ‘integrated hook endpapers’ — can indeed present a great number of different possible configurations. For this reason, one needs a precise terminology that could label each component, and a way to communicate the specific form of the structure. Usually the latter is attained through *ad hoc* graphic representations.

The lack of a uniform and established terminology in English — or in any other language for that matter — renders descriptions imprecise and liable to misinterpretation.<sup>197</sup>

To complicate matters further, there is not as yet a standard method for describing bindings and offering guidelines on what to observe, which elements should be recorded, to what degree of detail, and in what way. Different projects would need different levels of detail, but such guidelines, if flexible enough, could promote best practice, and contribute towards developing a standard of description,

---

<sup>195</sup>. Cloonan 1984; Tanselle 2002.

<sup>196</sup>. Cloonan 1984; Ravenberg 2012.

<sup>197</sup>. Szirmai 1999.

in a similar manner to what the Text Encoding Initiative (TEI)<sup>198</sup> has done for the description of texts and their supports. Incidentally, it should be noted that the TEI P5 Guidelines for the physical description of manuscripts do provide an element for the description of bindings; however, in line with the traditional description of bindings that can be found in catalogues of manuscripts,<sup>199</sup> this element is far from adequate for the purposes of a bookbinding historian, as the unstructured information there recorded tends to be generalized, superficial, and inconsistent.<sup>200</sup>

The *Ligatus* Research Centre of the University of the Arts London<sup>201</sup> has been developing a descriptive schema for bookbinding structures utilizing eXtensible Markup Language (XML) technologies, which, to tackle the terminology problem, has fed into the development of a comprehensive thesaurus of bookbinding terms<sup>202</sup> that goes down to the component level of complex structures.<sup>203</sup> An earlier version of the schema was used for the survey of the printed books of the library of St Catherine's Monastery on Mount Sinai, Egypt in 2007.

## 4.2. Verbal and visual descriptions of bindings

In the literature, one can find different types of descriptions of bookbinding structures. There are some that only make use of natural language without any visual integration, whilst others accompany text with photographs or drawings. More recent examples make use of controlled vocabularies and structure the information within databases.

The next few sections cover examples from the main description methodologies found in the literature. These are pure textual descriptions without any graphic

---

<sup>198</sup>. Sperberg-McQueen & Burnard 2005.

<sup>199</sup>. See for example Jemolo & Morelli 1990, or Petrucci 2001.

<sup>200</sup>. Pickwood 2012.

<sup>201</sup>. *Ligatus* from now onward. <http://www.ligatus.org.uk/>

<sup>202</sup>. <http://www.ligatus.org.uk/glossary/>

<sup>203</sup>. Pickwood 2004; Pickwood & Gullick 2004; Velios & Pickwood 2004; Velios & Pickwood 2005a; Velios & Pickwood 2005b; Velios & Pickwood 2008; Velios & Pickwood 2009.

representation, textual descriptions with photographs, textual descriptions with diagrams, controlled vocabularies, and structured descriptions.

#### 4.2.1. A DESCRIPTION OF COPTIC BINDINGS

A first example is taken from Henri Hyvernat's files in the *Corpus Scriptorum Christianorum Orientalium* in the Catholic University of America in Washington, DC, and transcribed by Theodore C. Petersen. This is a handwritten account in Italian from the librarian Enrico Castellani on the binding of Coptic Codices written in Rome in 1920. Since the text is rather short and unpublished, the whole page is given here (the translation from the original Italian is made by this author):<sup>204</sup>

##### *La Legatura dei Codici Copti*

*Sul dorso dei fascicoli (ternioni, quaderni, quinterni, etc.) sovrapposti regolarmente gli uni sugli altri, si fanno quattro cuciture.*

*Ogni cucitura è fatta con due spaghi della lunghezza di 60 Cent. l'uno.*

*Sui fascicoli cuciti e formanti già un volume, si accomodano i cartoni esterni, avvertendo che questi abbiano ai tre lati liberi, meno il lato del dorso, una sporgenza uguale di un centimetro scarso.*

*Sul piano del cartone, a circa quattro centimetri dal dorso, si praticano in corrispondenza delle quattro cuciture, altrettanti fori, con un punteruolo, [i.α] si prendono poi i due spaghi di ciascuna cucitura, e se ne fa un nodo aperto a forma di anello, si prende poi il capo dello spago di sotto, si fa passare attraverso il foro, e si fa riuscire al di sotto; si riuniscono quindi i due spaghi al dorso.*

*I due spaghi così riuniti si fanno poi passare corrispondentemente nell'anello, e si stringe il nodo sul dorso. La cucitura poi che deve unire le altre quattro sul piano del cartone, è più semplice.*

*Si prende un pezzo di spago lunga [sic] 60 Cent.; s'infilano due aghi grossi ai rispettivi capi, e col medesimo sistema della prima cucitura, ossia incrociando gli aghi, si passano da un foro*

##### *Coptic Binding*

*On the spine of the quires (ternions, quaternions, quinions, etc.), regularly placed one on top of the others, make four sewing stations. Each sewing is executed with two threads of the length of 60 cm each.*

*On top of the sewn quires, thus already forming a bookblock, place the external boards, in such a way that on the three free sides, less the spine edge, these project by about 1 cm.*

*On the board, at about four centimetres from the spine edge, make four holes with an awl at the four sewing stations; [i.β] tie then the two threads of each sewing station together in an open circular knot; pass then the end of the bottom thread through the hole in a downward motion; join then the two threads together at the spine.*

*Once the two threads are thus joined together, pass them through the open circular knot, and tighten the knot at the spine. The sewing pattern that joins the other four on top of the board is simpler.*

*Take a thread length 60 cm long, and, with two needles, following the same sewing pattern as before, that is crossing the needles, pass them through all the holes; having once reached the last hole, form a knot on the spine.*

*Rome, 3<sup>rd</sup> February 1920 / (received 4th February from Enrico Castellani) / Henri Hyvernat.*

<sup>204</sup>. Copied from the papers in Henri Hyvernat files: MC VIII.A.3.

*all'altro per giungere fino all'ultimo dove si  
formerà il nodo di chiusura.  
Roma, 3 febbraio 1920 / (remis le 4 fevrier par  
Enrico Castellani) / H[enri].H[yvernat].*

Let us consider one passage as example:

(i.β) *Tie the two threads of each sewing station together in an open circular knot; pass then the end of the bottom thread through the hole in a downward motion; join then the two threads together at the spine.*

What follows is an almost verbatim translation that retains as much as possible the flow of the original Italian description:

(i.γ) *The two threads of each sewing station are taken and an open knot is formed with them in the shape of a ring, the end of the thread below is then passed through the hole, and is driven out below; the two threads are then re-joined together on the spine.*

What this exactly means is not really clear, in either translation, as well as in the original Italian text. There are not real points of reference and the motion of the thread, as it develops from the bookblock sewing onto the board lacing, however detailed the description might have seemed at the time of writing, is rather confusing. A possible explanation of this particular kind of sewing might be found in the drawings of Theodore C. Petersen of the Coptic bindings at the Morgan Library in New York. See for example Figure 12.

This example shows how difficult it is to follow and understand structure from a purely textual description.

#### 4.2.2. A PARTICULAR SEWING PATTERN

Let us take a look at another verbal description. This time the original text is in German and describes a particular sewing pattern on double or split bands with the creation of a small knot between the two parts of the sewing support.

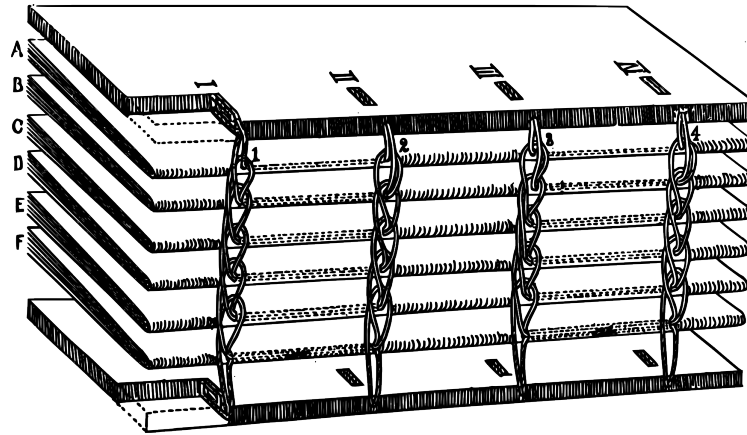

Figure 12. A sewing pattern for a Coptic binding at the Morgan Library, New York. (Petersen 1948).

Klee first described this sewing in 1978.<sup>205</sup> In the paper, Klee described the pattern by verbal means, and accompanied her description by a photograph of the spine of an actual book sewn in this manner. In 1989, Klee's article was translated and republished in English by Dorsey in the pages of the Binders' Guild Newsletter.<sup>206</sup> Dorsey had the original article translated into English, and he published both (ii.γ) a verbatim translation of the sewing pattern description and (ii.β) the same text translated in a more fluent manner.

All three texts are reported here: (ii.α) the original German description of the sewing pattern, and (ii.β; ii.γ) the two translations published by Dorsey.

(ii.α) *Der Faden führt von der Lagenmitte durch den Doppelbund nach vorn, die erste Bundhälfte wird umschlungen, dabei der Faden hinter dem Bund zur zweiten Bundhälfte geführt, und ebe der Heftfaden wieder zurück zur Bundmitte gestochen wird, wird die erste Bundumschlingung noch einmal erfaßt und der Faden gestrafft, wodurch der Knoten entsteht.*

(ii.β) *The thread goes from the inside of the signature through the center of the split band, from back to front. It then goes tightly around the center of the split band, from back to front. It then goes tightly around one half-band and behind both half-bands. Before the thread goes back between the half-bands into the signature as is usually done, it first goes around the first half-band again, then forward (from back to front) through the slit, and back over itself, then into the signature. When tightened, a knot is formed.*

<sup>205</sup>. Klee 1978.

<sup>206</sup>. Dorsey 1989.



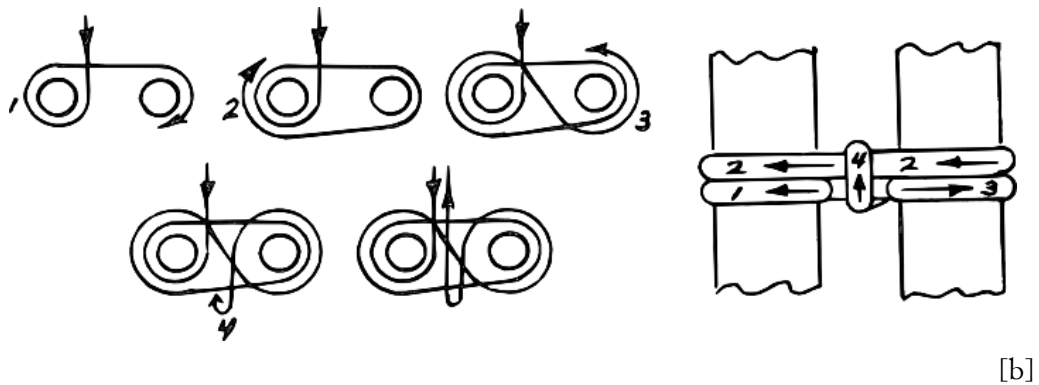
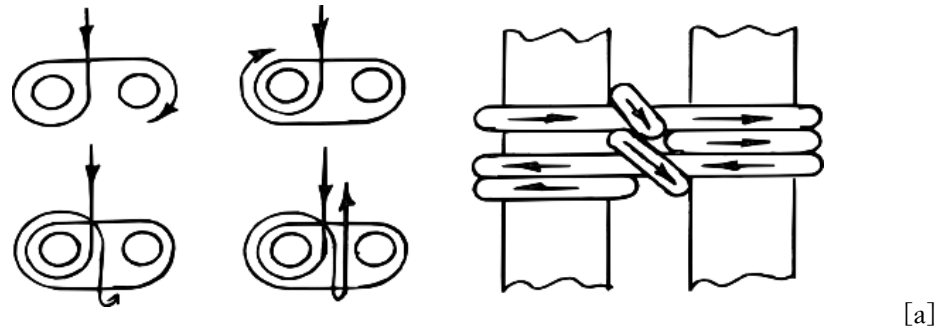

Figure 13. Two interpretations of Klee's description of the so-called knot-tack sewing. ([a] Dorsey 1989, p. 12; [b] Wurfel 1989, p. 14).

(ii.γ) *The thread guides from the signature middle through the double band forward from back to front, the first band half will become tight around while the thread behind the band to the second half is guided, and before the thread is stitched back to the band middle, the first band tight around is grabbed again a the thread will be tightened, resulting in making the knot.*

Dorsey then adds a graphic representation of the sewing pattern to make clearer his interpretation and to test the verbal description (see Figure 13[a]). However, either Klee's interpretation of the historical sewing pattern was flawed, or the description did not deliver the message. In fact, Dorsey's explanation, following the German text, is, by his own admission, not producing the same pattern depicted in the photographs in Klee's article.

A month later Wurfel,<sup>207</sup> in answer to Dorsey's article, proposed yet another interpretation of Klee's text based on Dorsey's translation (see figure 13[b]).

In 2012, Benvestito<sup>208</sup> proposed a new explanation of the sewing technique after the discovery and examination of two volumes presenting the characteristic knot in the sewing at the centre of the split band in the collections of the Marciana National Library, in Venice, Italy. Through direct examination of the volumes and ignoring the verbal descriptions that had accumulated over the years, she reached a different conclusion (iii), but one that would seem consistent with the photographs in the original article by Klee.

(iii.α) *La cucitura knot-tack [...] viene eseguita in due tempi: l'ago esce dal fascicolo, al centro del nervo tagliato, avvolge la porzione destra del supporto e, passando dietro al doppio nervo, compare sulla sinistra per dirigersi di nuovo verso il centro; qui aggancia dall'alto verso il basso il filo già presente, lo serra e, portandosi verso l'alto, rientra nel fascicolo [...] è evidente che nella cucitura knot-tack non fosse prevista la compensazione.*

(iii.β) *The knot-tack sewing is executed in two phases: the needle exits the gathering in the middle of the split band, it wraps the right section of the sewing support and, passing behind the double band, it appears on the left and then goes back to the centre. Here it locks with a downward motion the thread already present, and it then re-enters in the gathering. [...] Evidence shows that this was not a packed-sewing.<sup>209</sup>*

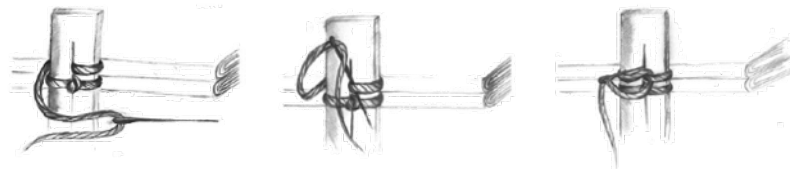

Figure 14. Knot-tack sewing alternative solution (Benvestito 2012, p. 297).

These examples show how photographs alone are not able to convey enough information about complex structures, and confirm the inadequacy of strict verbal descriptions in communicating spatial information. The diagrammatic visualizations

<sup>207</sup>. Wurfel 1989.

<sup>208</sup>. Benvestito 2012.

<sup>209</sup>. Author's translation.

that accompany the last three examples are however capable of integrating the texts, communicating structure more successfully.

#### 4.2.3. A CONTROLLED VOCABULARY DESCRIPTION

The authors of the two verbal descriptions in the examples above made use of natural language and described the binding and sewing techniques in a logical but free manner. In the next example instead, Spitzmueller and Frost<sup>210</sup> have developed a controlled vocabulary for the description of sewing patterns through the fold of the gatherings. The result is a precise description of the path of the thread with a rather ‘mechanical’ feeling to it. Examples (i), (ii), and (iii) are easy to read, but, as seen, can be difficult to interpret, whereas, example (iv), with its cumbersome asyndetic list of actions, is not easy to read, but, with some effort, it can be precisely interpreted. Figure 15 shows a graphic representation of the sewing described in example (iv).

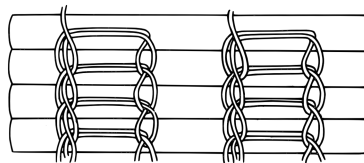

Figure 15. Unsupported sewing sample (Spitzmueller 1982, 46).

- (iv) *Unsupported structure: chainpattern across spine; in-line, periodicfold pattern. There are 4 sewing stations — A is at the head and D is at the tail. 2 needles are used, each sewing between 2 stations — A & B or C & D. They sew independently but identically. Enter at A, continue-on to B, exit, dropto-the-outside, link, climb, enter at B, reverse, exit at A, dropto-the-outside, link, climb, change-over and enter at A of section 2.*

Natural language and controlled vocabulary are mixed in the description. In the text, the terms prescribed by the proposed vocabulary have been underlined. The terminology develops on three levels: (1) from the general sewing structure,

<sup>210</sup>. Spitzmueller & Frost 1982; Spitzmueller 1982.

(2) to the resulting sewing pattern, as seen both from inside the fold of the gathering and from the spine, and finally (3) the sewing stitch. This third level describes in detail the motion and path of the thread from a sewing station exit to its entry in the next sewing station for books in codex-form sewn through the fold. Many of the terms are traditional bookbinding terms, but where traditional terminology lacked precision, the authors selected new terms or phrases to pinpoint verbally the detail in focus. The sewing structure is described here as being unsupported (*unsupported structure*), as it has only the sewing thread as a way to secure the sections to each other. On the spine the sewing pattern takes the form of a chain sewing (*chain patterns across spine*), while inside the fold it presents a periodic pattern (*periodic fold pattern*), with intervals within some stations. All sections have exactly the same internal pattern and the thread lengths appear between the same stations (*in-line*). The thread path is described as entering at the sewing station more towards the head of the bookblock (A), it then enters a station (B) in the same gathering (*continue-on*), it exits on to the spine, it moves downward (*drop*) towards the tail of the bookblock (*to-the-outside*), it passes under another thread (*link*), it moves upward (*climb*) and re-enters at the station B, it continues in the opposite direction of progression (*reverse*), it exits at station A, it moves downward (*drop*) towards the head of the bookblock (*to-the-outside*), it passes under another thread (*link*), it moves upward (*climb*) and enters station A in a gathering that is different from the one exited (*change-over*).

While this verbal description does take some effort to read, it is nonetheless able to convey more precisely than the previous examples the motion of the thread. This is achieved through the use of the proposed controlled vocabulary, and it is achievable because the nature of the structure described is essentially sequential in nature. Following the motion of the thread step by step, in fact describing how the sewing was carried out, this description dictates a series of actions to be taken in order to reproduce the sewing.

This methodology and controlled vocabulary has been extended by Palmer Elbridge,<sup>211</sup> and used by Szirmai,<sup>212</sup> integrating it with the descriptive approaches

---

<sup>211</sup>. Palmer Elbridge 1993; Palmer Elbridge & Prior 2008.

<sup>212</sup>. Szirmai 1999.

taken from the Dutch systematic vocabulary introduced by Gnrirrep and colleagues,<sup>213</sup> to describe a link-stitch process.<sup>214</sup>

This approach resembles the use by De Luca and colleagues<sup>215</sup> of classical architecture structured and granular technical vocabulary included amongst the cultural heritage visualization examples in chapter 2. Where one terminology uses actions, the other uses precise figural concepts, but in both cases, the descriptions can proceed strictly in a sequential manner.

#### 4.2.4. STRUCTURED AND CONTROLLED VOCABULARY DESCRIPTIONS

Other scholars have developed a more rigorous approach to the recording of bindings and their structures. Abandoning the idea of natural language descriptions altogether, they have turned to record the necessary information within databases thus allowing for the implementation of a systematic method of examining a book. This way, every book is described in the same manner, and this usually means following how the object was constructed, from the inside out, from the formation of the gatherings, through the codex assembly structure, to the covers and their decoration.<sup>216</sup> The normative nature of these descriptions guides both the compiler and the reader through a commonly understood hierarchy of information, thus solving, up to a point, some of the problems found in prose-based descriptions.

An example of this methodology of description is the XML schema developed by *Ligatus*. This is a good example of the use of a hierarchical database for storing data on bookbinding structures and their state of conservation.<sup>217</sup> The hierarchical structure, running from the more general to the more specific, allows book com-

---

<sup>213</sup>. Gnrirrep *et al.* 1992.

<sup>214</sup>. 'The thread, proceeding in the centrefold, exits through a sewing hole at a given sewing station where it drops in order to make a link under the sewing thread of the previous quire [...] it then climbs and re-enters through the same hole and makes a *long stitch* to the next sewing station' (Szirmai 1999, p. 16). Underlined words are from the Spitzmueller and Frost (1982; 1982) controlled vocabulary, italic words are from Gnrirrep and colleagues (1992).

<sup>215</sup>. De Luca *et al.* 2005; De Luca 2013.

<sup>216</sup>. Federici & Houlis 1988; Federici *et al.* 1988; Houlis & Pescalicchio 1988; British Census Project 1990; Federici & Pascalicchio 1993; Grosdidier de Matons *et al.* 1993; Sharpe 2000; Pickwood 2004.

<sup>217</sup>. Ravenberg 2012.

ponents and their characteristics to be arranged in groups, and then an unlimited number of groups within these groups, down to the desired level of detail.<sup>218</sup> The records are combined with photographs of the volumes and freehand drawings of the binding structures.

Listing 1 and Figure 16 show an example of an XML description for a sewing station of a printed book volume from St Catherine's Library along with detail of the photograph of the spine showing an exposed sewing support and drawing of the sewing type:

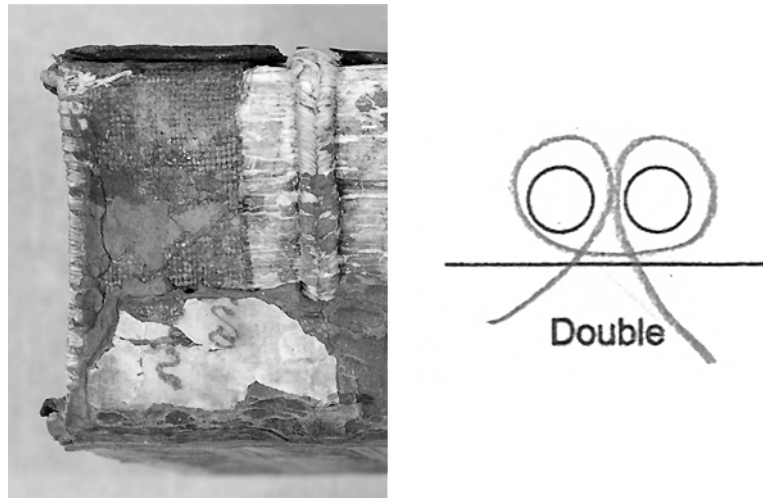

Figure 16. Photograph and drawing of sewing for Vol. 126.60β, St Catherine's Library.

---

<sup>218</sup>. Ravenberg 2012.

```

<sewing>
  <numberOfStations>7</numberOfStations>
  <status>
    <firstSewing/>
  </status>
  <type>
    <allAlong/>
  </type>
  <stations>
    <station> ... </station>
    <station>
      <measurement>36</measurement>
      <group>
        <current/>
      </group>
      <preparation>
        <NK/>
      </preparation>
      <numberOfHoles>1</numberOfHoles>
      <type>
        <supported>
          <type>
            <double>
              <route>
                <drawingDone>
                  <no>1</no>
                </drawingDone>
              </route>
              <linking>
                <linked/>
              </linking>
            </double>
          </type>
          ...
        </supported>
      </type>
    </station>
    ...
  </stations>
  ...
</sewing>

```

Listing 1. Snippet of XML description of a sewing station from codex 126.60β, St Catherine's Library.

The XML schema functions as a grammar for the description of the binding, it is a model *of* the binding of books. Elements described by verbal means within the hierarchical structure of the XML records are readily available for machine searching, making it easy for specific pieces of information to be found and compared. In these descriptions, information is organized into hierarchies, and within these hierarchies, tokens of information that together serve to describe a particular feature or part are grouped and presented conjointly. This allows significant bits of information to be brought forward that carry with them all the semantic information contained in the structure.<sup>219</sup> By grouping the information in this manner, it is possible to provide elementary details of the configuration of the material components being presented within the description. This will be further analysed in chapter 7 which presents the empirical data for the transformation of structured descriptions of bookbinding structures into diagrammatic visualizations.

The fragmentation of the information within the fields of the XML-based database description is an obstacle for a human reader attempting to analyse and compare the data. A reader would have to muster in his mind — and more precisely in his working memory buffer — a number of fragmented pieces of information; the more components come together in a given structure, the more pieces of information would have to be kept in mind, analysed, and subsequently joined into a coherent entity. As noted in the introduction, our working memory can hold only a very limited amount of information<sup>220</sup> — some scholars<sup>221</sup> mention three to five chunks of information, others<sup>222</sup> up to seven or nine — and the fragmented information contained in databases can consequently be difficult to reintegrate into a mental conceptualization and visualization utilizing the structured verbal description alone. The working memory buffer can be freed by recurring to external memory devices, or exograms,<sup>223</sup> thus allowing memory space for analysis

---

<sup>219</sup>. Brachman & Levesque 2004; Gnoli 2008.

<sup>220</sup>. Baddeley & Hitch 1974; Baddeley 1992; Baddeley 2004; Alloway & Alloway 2012; Bor 2012; Baddeley 2013.

<sup>221</sup>. Cowan 2001; Gobet & Clarkson 2004.

<sup>222</sup>. Miller 1956; Saaty & Ozdemir 2003.

<sup>223</sup>. Donald 1991; Donald 2001; Alloway & Alloway 2012.



and comparison. A system to gather the fragmented data and present it in a coherent unified manner to the reader could easily work as a suitable exogram.<sup>224</sup>

From these examples it is clear that natural language alone is not capable of communicating specific and detailed descriptions to allow a reader to derive one and only one possible interpretation of what was described.

Also, there is another crucial problem with natural language descriptions: that of the translation into other idioms, e.g. English to Italian. As each language has its own grammatical rules and terminologies, the passage of information can create indeterminateness. The problem of the translation and verbal imprecision is lessened by the use of controlled vocabularies and multilingual thesauri as they fix the concept and not the labels for it.

### **4.3. Prototypical visualization of bookbinding elements**

In 1928, Goldschmidt<sup>225</sup> pointed out that the literature on bookbinding can be divided into three main kinds: (i) books of plates, (ii) bookbinding manuals and handbooks, (iii) and highly focussed articles in a number of journals that need a good corpus of reliable published material for reference and comparison. The current situation is still virtually the same.

Books of plates are plentiful, though for the most part concentrated on decorated bindings and the reproduction of just the exterior of bindings. Manuals and many articles make often ample use of schematic drawings as well as photographs to help interpret and categorize bookbinding structures. Not all drawings, however, are informative enough and suitable for communication, and different styles are useful for delivering different kinds of information. The lack of a standard way of depicting bookbinding structures can be linked to the fact that the bookbinding trade is based on craftsmanship. Artisans, unlike engineers for example, do not need to show a vision of a structure for others to then construct it, but rather they

---

<sup>224</sup>. Kirsh 2002.

<sup>225</sup>. Goldschmidt 1928.

visualize it in their mind and then will construct it themselves. Therefore, there was never the need to develop a graphic language to communicate bookbinding structures efficiently to others.<sup>226</sup> In addition to this, unlike archaeology, the young age of the discipline has not allowed for any standardized drawing methodologies to be established.

There is, therefore, no standard practice to illustrate bookbindings and their structures, and different authors employ different styles and conventions; in fact it is not uncommon to find different conventions used by the same author within one publication. Authors of conservation and bookbinding manuals have made use of professional illustrators for their publications,<sup>227</sup> but otherwise, for the most part, the scholars are responsible for both the text and the illustrations. As mentioned, archaeology has developed standardized graphic conventions (see Figure 17 for examples of archaeological drawings), but these are seldom applied to bookbinding studies.

#### 4.3.1. GATHERING ASSEMBLY DIAGRAMS

One simple structure that is common to any book in codex form, and that often needs to be graphically represented by scholars dealing with the range of subjects that have the book as their object of study — e.g. codicology, palaeography, bibliography, or bookbinding — is the gathering or section assembly.

Different conventions are used by different scholars to represent the pages of a book within a gathering. Different uses and kinds of information do call for different conventions and spatial layout, however, it can be argued that there is scope for a more standardized approach to the representations of such basic book structures, one that takes into account perception and prototypification of shape on the one hand, while allowing for special cases, if needed, being general and prototypical enough on the other.

---

<sup>226</sup>. Ferguson 1992.

<sup>227</sup>. Cockerell 1953: with drawings by Noel Rooke and other illustrations; Cockerell 1958: with illustrations by Joan Rix Tebbutt.

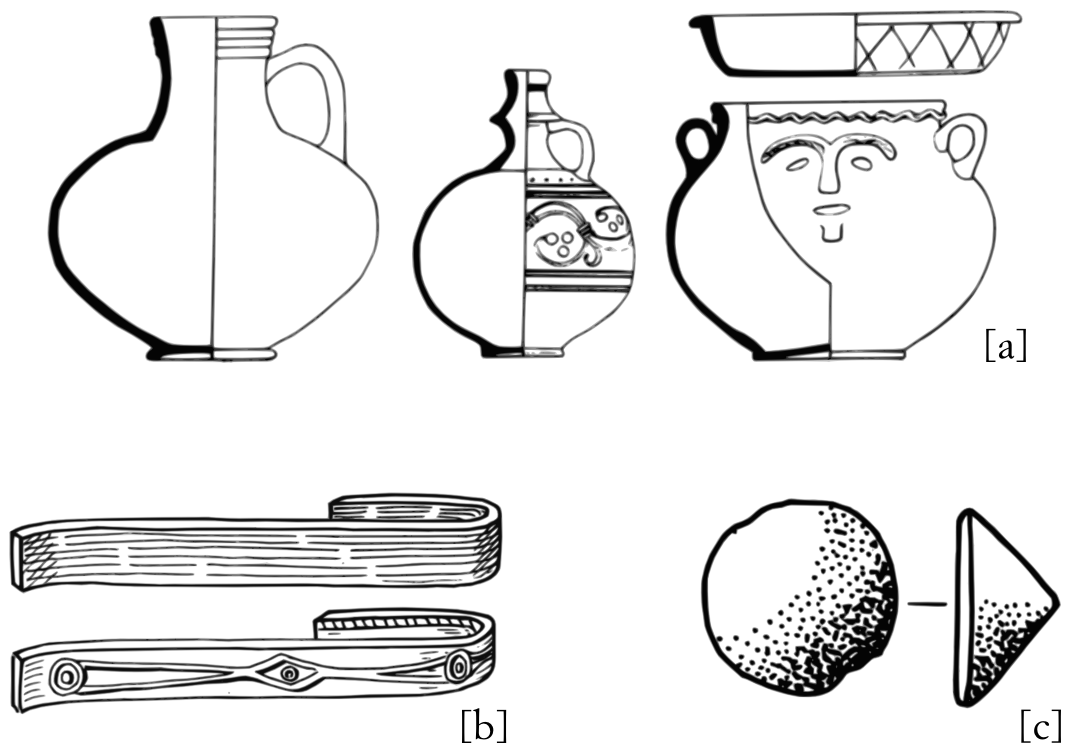

Figure 17. Archaeological drawings. [a] Examples of standard practice to illustrate pottery with elevation and surface details on the right-hand side and a regularized section in solid black on the left. Examples of texture rendering: [b] plain and patterned bronze piece; [c] cone of dark glass with stipple and dot technique to show texture and shading together. Surface texture is used to enhance appearance and value of a drawing, but care is taken not to confuse structural lines and texturing. The drawings here reproduced are not in scale ([a] Webster 1964, fig.1, p.35; [b] and [c] Brodrigg 1970, fig.24–25, pp.42–43).

Figure 18 and Figure 19 show some graphic representations of gatherings taken from various books and articles published by scholars ranging from bibliographers and codicologists, to conservators and bookbinding historians. In the first group, the author of each drawing has decided to use a naturalistic three-dimensional approach to represent a gathering, while in the second group a more symbolical approach has been taken.

#### 4.3.II. NATURALISTIC REPRESENTATIONS OF GATHERINGS

There is no doubt that a naturalistic and three-dimensional representation is more impressive and, maybe even pleasing to the eye when well-executed. However, the scope of such representations, it can be argued, is not that of showing

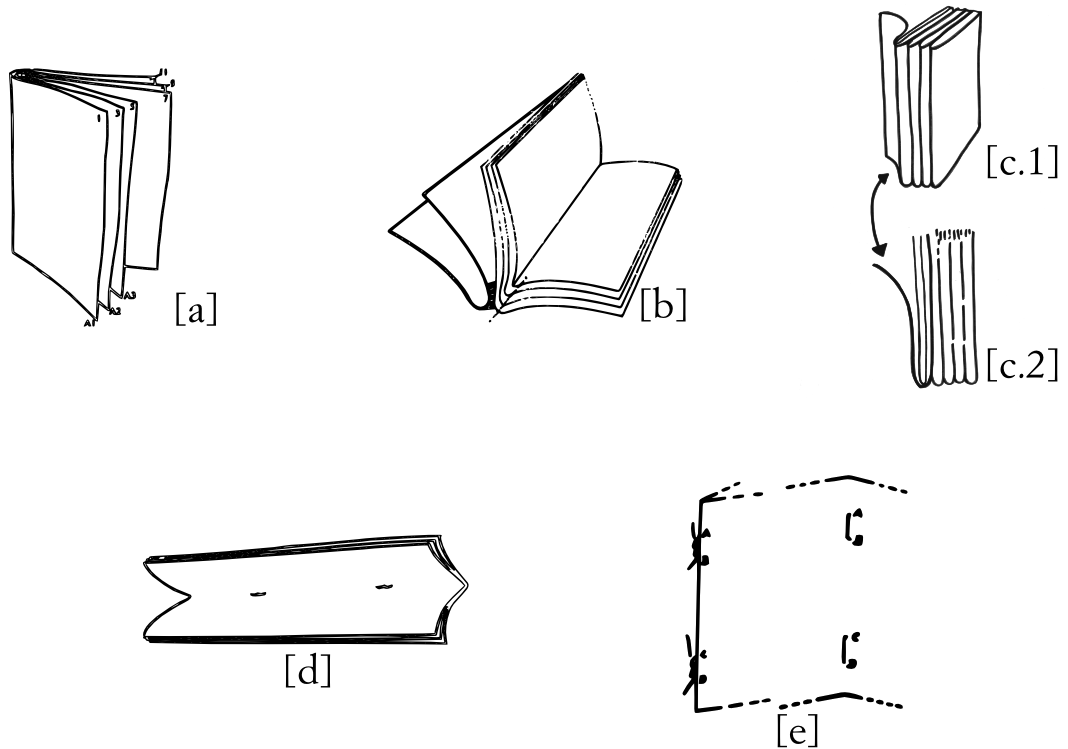

Figure 18. Naturalistic and three-dimensional representations of gatherings. ([a] Gaskell 1972, fig. 45, p.83; [b] Federici & Houlis 1988, fig. 11, p.22; [c.1-2] Sheppard 1995, p. 193; [d] Clarkson 1996, fig.4, p.218; [e] Regemorter 1992, p. 141).

how a gathering might look like in general, rather, the aim is to present the reader with some information regarding the specific gathering represented, and to make it comparable with other gatherings.

#### 4.3.1.2. SCHEMATIC REPRESENTATIONS OF GATHERINGS

The collection of drawings in Figure 19 shows a series of schematic representations of gatherings. In these drawings though, the balance between the iconic nature of such representations and their inherent symbolism generally leans greatly towards symbolism, often disregarding almost completely the natural shape of the object represented. Thus the pages of a gathering are represented by V-like signs on the one hand (Figure 19[a]), and square or rounded horizontal U-like signs on the other (Figure 19[a-d]). The problem with the V-like representation is that, although easy to draw, the overall shape of the gathering tends to either fan out (like in Figure 19[a]) or to distort the shape of the inner pages (that become

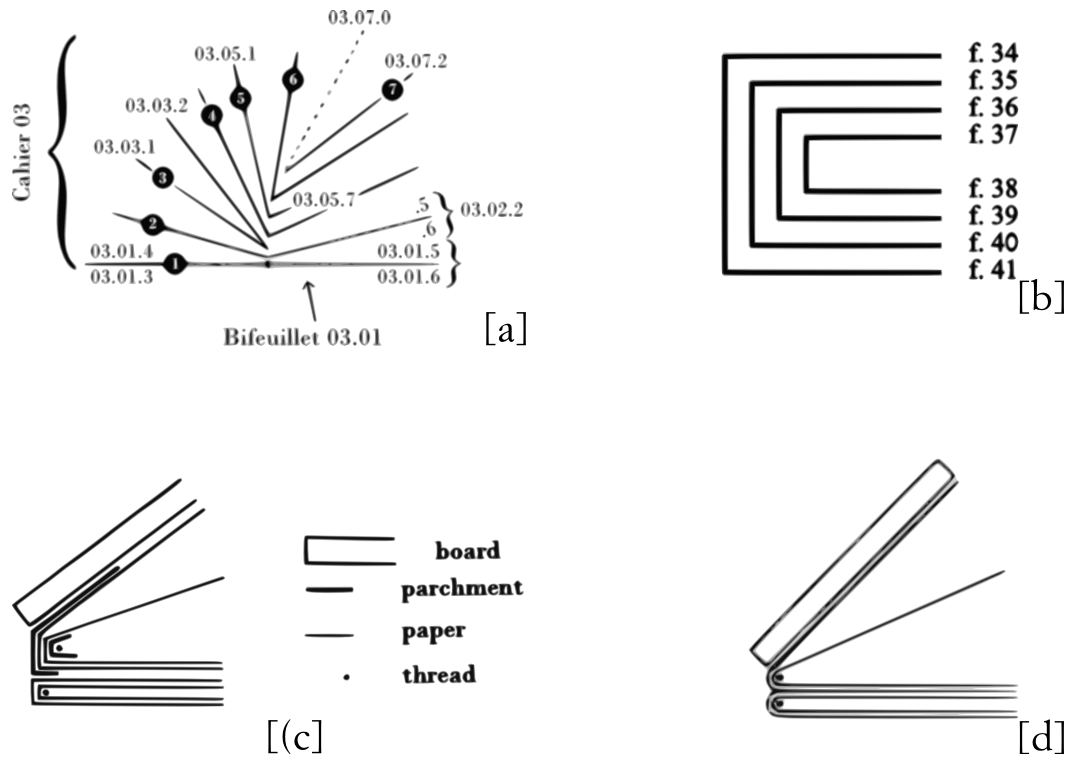

Figure 19. Schematic representations of gatherings. ([a] Muzerelle 1985, fig. 56; [b] Noel 1995, fig. 11, p. 8; [c] Szirmai 1999, fig. 9.2[s], p. 179; [d] Szirmai 1999, fig. 8.4[e], p. 147).

smaller and smaller), or else these are unnaturally projected forward as each sheet representation maintains the same sharp V-shaped fold and size. Either way, apart from being particularly inelegant and cumbersome, these representations, unnatural as they are, make it particularly difficult to compare representations of different gatherings and do not take into consideration the objects they are trying to represent. This is because, even if a single sheet of paper, when folded, does create a V-shaped fold, when multiple sheets are folded together, the thickness of the other sheets forces the V-shaped fold to round up creating a more gentle U-shape.

Another solution often used is that of foregoing altogether with any naturalistic representation and using square open boxes to symbolize each sheet. This can be seen in Figure 19[b] and [c]. In this case the length of each sheet is directly proportional to that of the sheet represented, but the shape of the fold is completely unnatural. Although there is nothing wrong in deciding to use a totally symbolic shape, the choice does not have to compromise the possibility of representing particular cases and it should not be possible to confuse such elements with others

of the same structure. It is indeed easier to draw straight lines and square angles, rather than nicely shaped curved lines, but, such a shape should not be confused with anything else. See for example the diagram in Figure 19[c]. This drawing comes with a very useful legend explaining how to read and interpret each element, however, on a closer look, because of the choice of drawing the gatherings with a square spine, the legend and the drawing result in being confusing: if the symbol for the board is an open box with square corners, one might read the drawing as describing a strange book made up of a series of boards. Obviously this is not the case, but the square gathering spines create a possible problem in the interpretation of the drawing. See how this is not the case in Figure 19[d], where the pages of the book are represented by nicely rounded shapes.

As in many structures that form a codex, there is a great number of possible permutations of how a gathering structure can present itself, depending on the number of sheets and their configurations. Bibliographers and manuscript scholars have developed precise and highly condensed collation formulas to communicate this information,<sup>228</sup> however it is often necessary to also visualize these for easier communication and understanding of more complex structures. Because of this, and since drawing appropriate shapes by hand can be difficult, it would seem that a system that allowed an automated generation of such shapes and diagrams would be welcome. Better shapes could be drawn this way, and the process would not be as time-consuming as drawing them by hand. Recently, the issue has been raised in a few occasions in the community.<sup>229</sup>

To conclude, an ideal shape should be able to accommodate particular cases, and maintain consistency at all times. For elements of an object's structure — as in the case of bookbindings — keeping a good balance between the iconic and the symbolic nature of the representation, and preserving the prototypical shape of its object, would allow to generate a standardized approach that takes into consideration perception and prototypification of shape, and is symbolic enough to allow straightforward comparison between distinct representations. For the

---

<sup>228</sup>. Bowers 1949/1994; Gaskell 1972; Gruijs 1974; Muzerelle 1985; Zappella 1996.

<sup>229</sup>. See for example Wragg 2012; Porter 2013.

particular case at hand, to represent a gathering, a better choice would be a cross section view that preserves the natural roundness of the sheets at the fold, like the example in Figure 19[d].

#### 4.4. A categorization of bookbinding illustrations

In the literature on bookbinding, different styles of drawings are used for different reasons and to deliver a diverse range of information. Each style is appropriate for a specific set of uses, and it should be chosen according to the kind of information that one needs to deliver.

Each different style can be regarded as a step in a categorical scale, going from very specific and exclusive, to general and inclusive, just as words and concepts within a categorical system, as presented in the previous chapter. A representation of the categorical scale is reported in Figure 20. As mentioned in chapter 3, line drawings represent a basic level of graphic abstraction, as they preserve the minimum amount of information that is necessary to precisely represent the category of an item.

##### 4.4.1. ARCHAEOLOGICAL-STYLE DRAWINGS

Some bindings are so particular and unique that it is necessary and good practice to present the information gathered on them by both photographic means and detailed drawing. This is common practice for archaeological finds and it is not surprising that drawings executed for these purposes make use of the same set of graphic rules usually implemented by archaeologists to depict their finds for publication.<sup>230</sup> For this reason these drawings will be referred to as *archaeological-style drawings*. Some examples of this kind of illustrations are presented in Figure 21. As it can be seen, the unique peculiarities, and the history, the signs left by

---

<sup>230</sup>. Brodribb 1970; see also Figure 17 for examples of archaeological drawings.

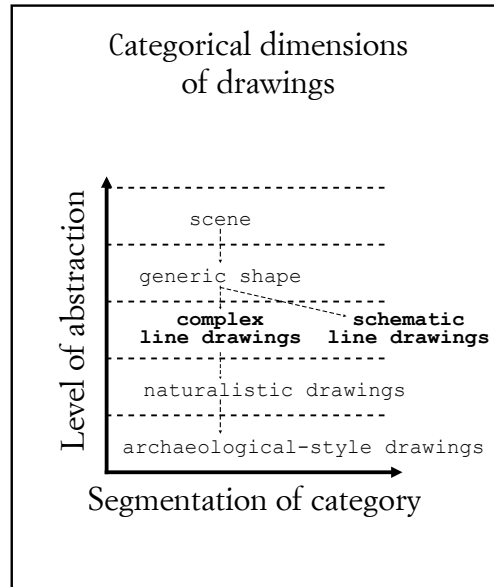

Figure 20. Categorical dimensions of drawings. The basic level of abstraction, in bold, is represented by line drawings; these can be complex or schematic.

time on the items depicted, are preserved and faithfully reproduced in the illustrations, and no attempt is made to generalize shapes and characteristics.

As noted earlier, there are no standards and guidelines in the literature on how to draw bookbindings and their structures. Sharpe<sup>231</sup> sets some general guidelines on how to approach and execute archaeological-style drawings, with direct references to drawing manuals for archaeologists and scientific illustrators.

Drawings of this style represent a specific object. As seen in the previous chapter, verbal descriptions are not capable of conveying the specificity of an object. It is thus not possible to generate automatically archaeological-style drawings from verbal descriptions.

#### 4.4.2. NATURALISTIC DRAWINGS

Sometimes it is appropriate to describe graphically a specific item of a specific category with very detailed and naturalistic drawings, either because of its uniqueness, or as a first step in drawing general conclusions on the category being

<sup>231</sup>. Sharpe 2000.



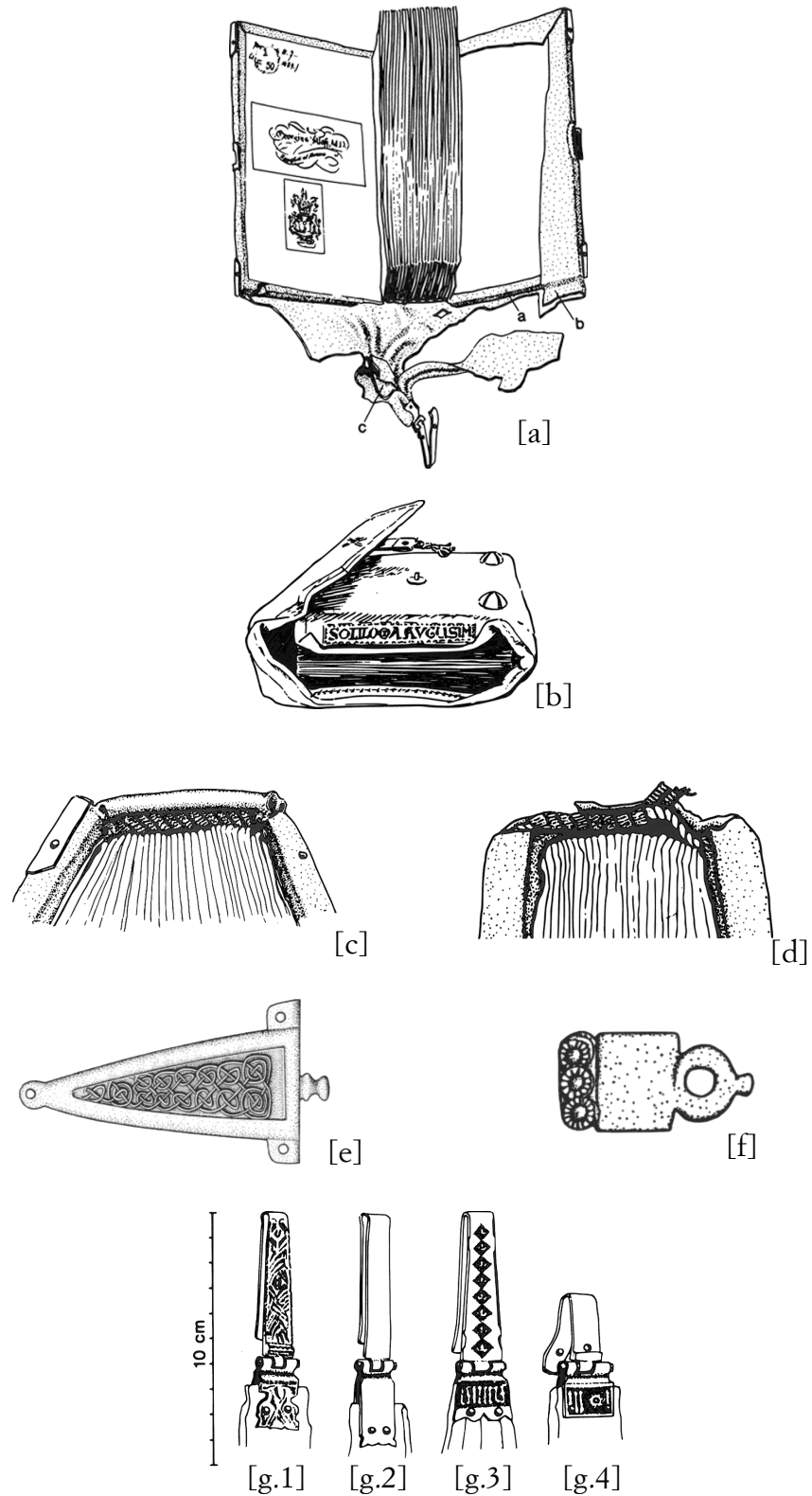

Figure 21. Archaeological-style drawings. The history and the peculiarities of the item depicted are preserved and faithfully reproduced. ([a] Szirmai 1988, fig. 3, p. 24; [b] Clarkson 1993, fig. 1, p. 184; [c] Szirmai 1988, fig. 8[a], p. 30; [d] Szirmai 1988, fig. 8[c],

p. 30; [e] Adler 2010, fig. 3–02, p. 61; [f] Adler 2010, fig. 3–07, p. 62; [g.1-4] Szirmai 1988, fig. 9[a–d]).

represented by the item. These will be referred to as *naturalistic drawings*. Examples of illustrations of this kind are presented in Figure 22. These illustrations tend to be a kind of graphic reconstruction of specific items, that, while preserving a high level of detail and surface texture, come closer to a generalization of shape, purposely removing signs of time — e.g. asymmetries are mostly removed and converted into symmetries — and showing an idealized graphic description. The drawing approach of these drawing resembles that of highly detailed scientific illustrations.<sup>232</sup>

Also in this case, these drawings tend towards the specificity of an object, and it is therefore not possible to generate them automatically from verbal descriptions without additional information.

#### 4.4.3. LINE DRAWINGS

The next step up the graphic categorical scale is represented by line drawings. As mentioned above, these are able to convey shape information precisely and for the most part effortlessly. They also represent a graphic equivalent to the basic level of abstraction of verbal categories. Line drawings, in fact, are capable of delivering the minimum amount of information that is necessary to represent graphically the category of an item.<sup>233</sup> They are inclusive enough to be successfully used to communicate shape, and exclusive enough not to represent too wide a group of instances of their category. Figure 23 shows examples of line drawings. These drawings, all highly selective in the amount of information delivered, can further be subdivided into two groups: on the one hand, one can distinguish multi-layered and three-dimensional drawings ([a], [b], [c], and [d.2]); on the other hand, there are schematic and strictly bi-dimensional drawings ([d.1], [d.2], and [e]). The two kinds of line drawings can be seen as two variations of the same

---

<sup>232</sup>. Wood & McDonnell 1994.

<sup>233</sup>. Rosch & Mervis 1975; Rosch *et al.* 1976; Tversky & Hemenway 1984.

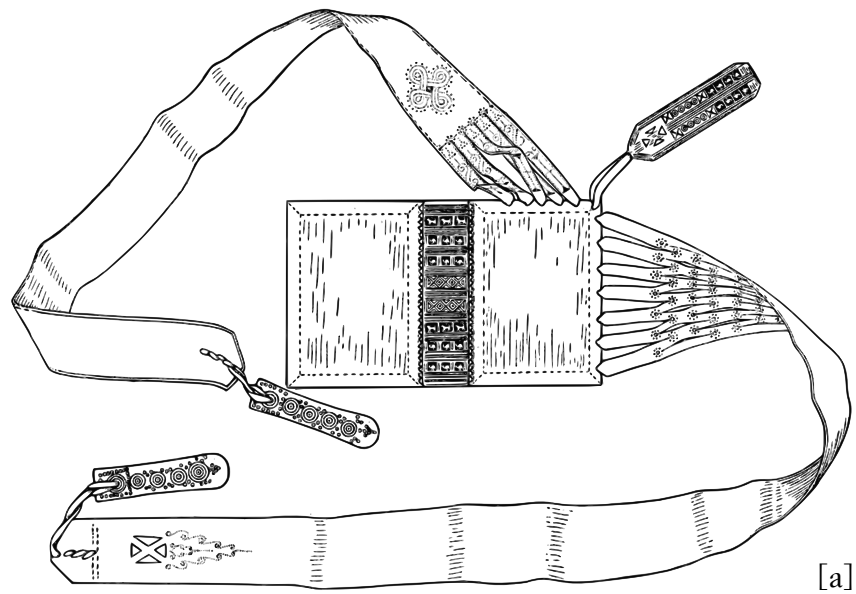

[a]

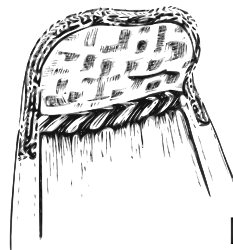

[b]

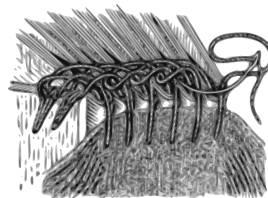

[c]

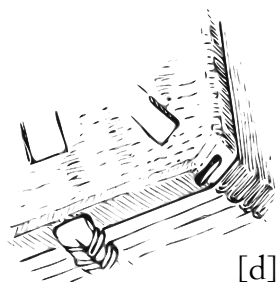

[d]

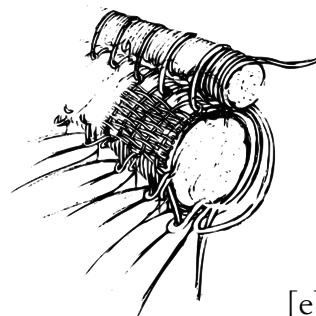

[e]

Figure 22. Naturalistic drawings. The general shape of the item is reconstructed and faithfully reproduced with abundance of details and surface textures. ([a] Petersen 1954, fig. 8, p. 46; [b] Clarkson 1993, fig. 5, p. 196; [c] Petersen 1954, fig. 22, p. 55; [d] Clarkson 1993, fig. 12, p. 190; [e] Boudalis 2007, fig. 58, p. 44).

basic level of abstraction within a graphic categorical system, developing its horizontal dimension. The former group will be referred to as *complex line drawings*, whilst the latter as *schematic line drawings*. Both groups are generated by a process of generalization of shapes that aims at describing graphically a prototypical instance of a category.

If an object is described verbally at the basic level of abstraction, the terms are capable of delivering enough information for the generation of schematic line drawings conveying information on the parts of an object and its prototypical shape.

#### 4.4.4. GENERIC-SHAPE DRAWINGS

A line drawing can also only portray the very generic shape of an item, foregoing, once again, any naturalistic detail, on the one hand, but also limiting the amount of information on shape to the bare minimum with very little attention to details, on the other. These shapes are too general to communicate the necessary information to distinguish between specific items, as they fail to preserve the parts-form relationship of its object and its functions — with the exception of the very basic elements — and are the graphic equivalent of generic verbal concepts like *furniture* as opposed to *table*. This particular kind of line drawing will be referred to as *generic-shape drawing*. Figure 24 displays some examples of such illustrations. Note for example the books in the timeline [a]: the drawing depicts the evolution of the book in codex form from the 2<sup>nd</sup> century CE to the 20<sup>th</sup> century, but the shapes are so generic that very little information is given on the actual differences between the different binding styles.

Drawings of this style could be generated from generic verbal labels, but, as it will be seen in chapter 6, the shapes thus generated would be too inclusive to be useful and carry more information than the verbal label alone.

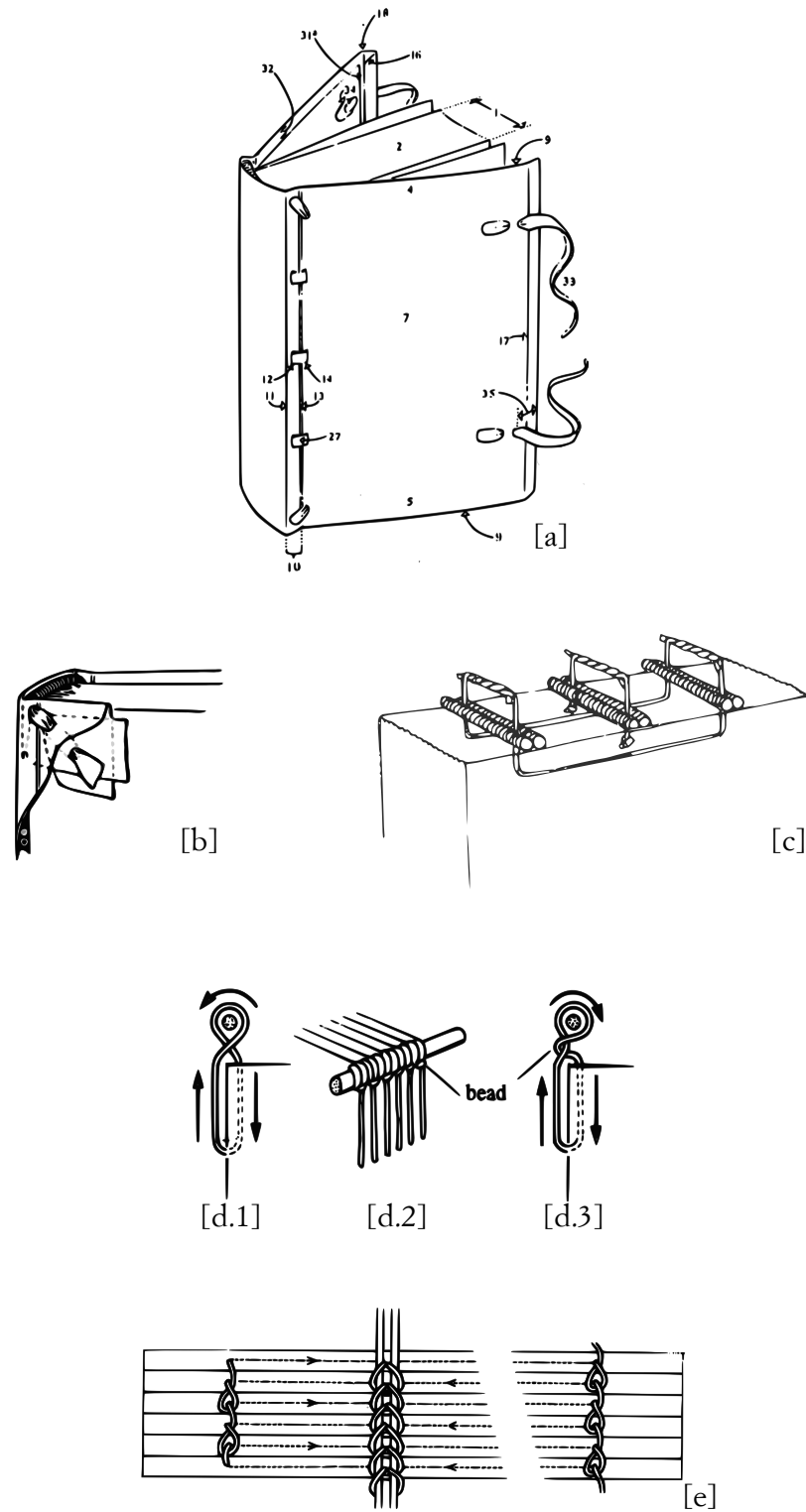

Figure 23. Line drawings, the graphic basic level of abstraction. These drawings can be multi-layered and three-dimensional — but still highly selective in the amount of information delivered — or more schematic and strictly bi-dimensional. ([a] Clarkson 2005, p. 22; [b] Clarkson 2005, fig. 4, p. 8; [c] Pickwoad 2000, fig. 27, p. 158; [d.1-3] Szirmai 1999, fig. 9.22[a-c], p. 207; [e] Szirmai 1999, fig. 7.16[a], p. 116).

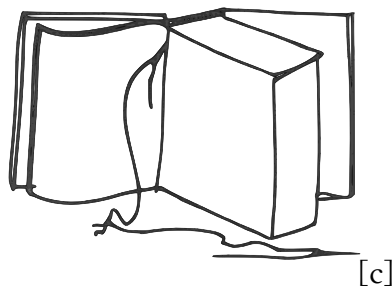
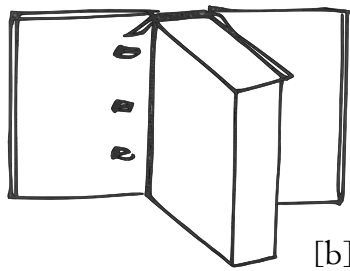
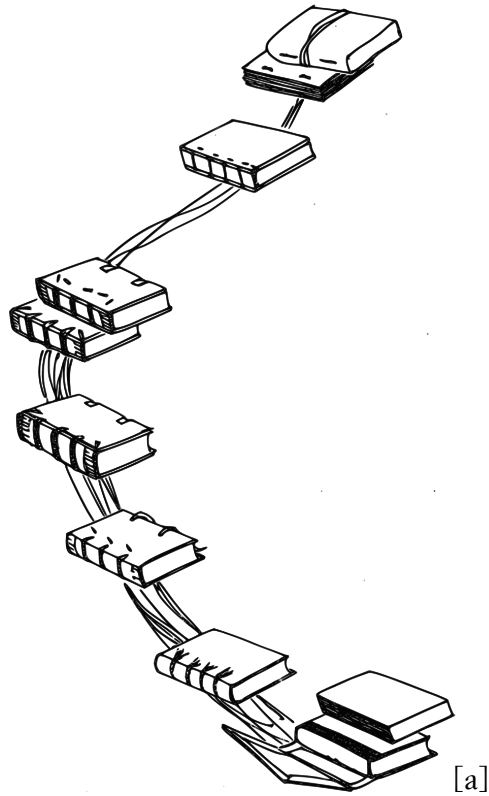

Figure 24. Generic-shape drawings. The shape of the drawn items is so generic that it does not show much more information than identifying the object for what it is — e.g. a book in codex form. Note for example the books in the timeline [a]: the drawing depicts the codex from the 2<sup>nd</sup> century CE to the 20<sup>th</sup> century, but very little information is given on the actual differences between the various binding styles. ([a] Greenfield 1998, p. 79; [b] Greenfield 1990, p. 78; [c] Greenfield 1990, p. 79).

#### 4.4.5. SCENES

Sometimes bookbindings are depicted within pictorial scenes, like the small watercolours found in Dirk de Bray bookbinding manual.<sup>234</sup> The depiction of books in these scenes can be very useful to analyse how historical bindings were bound, or how these bindings worked and behaved, but often, the shapes used to depict them are generic, deformed by perspective representation, and frequently misshapen or partially hidden to accommodate other elements in the scene. For these reasons, they can be put at the very top of the categorical scale of bookbinding drawings. It should be noted, however, that not every pictorial depiction of books within scenes is so generic, and they need to be evaluated case by case. These depictions will be referred to as *scenes*.

Drawings of this style are part of the narrative of a scene and are inherently visual in their nature. It is doubtful how useful it would be to try to generate them from verbal inputs.

The different kinds of graphic descriptions of bindings found in the literature can then be classified according to a categorical scale, going from very specific and exclusive drawings, to general and inclusive ones, within the vertical and horizontal dimensions of a categorical system. The various steps within such a scale have been clearly separated here and examples have been presented for each level of shape abstraction. Of these, schematic line drawings represent an ideal level of abstraction for the generation of diagrams from verbal input.

### 4.5. Clarity of information in bookbinding line drawings

So far, this chapter has analysed and categorized the kinds of bookbinding illustrations found in the literature. Each type can be successfully used to deliver information for different purposes. Obviously, there are degrees of success in the use of drawings to illustrate bookbindings, but the primary purpose of graphic

---

<sup>234</sup>. Bray 1607-1658; Bray 1658/1977.



Figure 25. Bookshop scene: 'Mensen en twee honden in een boekenwinkel' (People and two dogs in a book shop), pen and brown ink, brush in grey on paper, Dirk de Bray, 1607-1658. (Bray 1607-1658).

material — just as writing — should be to convey the right amount of information, with as much clarity and intelligibility as possible.

There are some general rules that can be learned from illustration in general, and archaeological drawings in particular:<sup>235</sup> (i) edges of boxes and geometrical shapes should be kept neat and tidy; (ii) the mixing of many different styles together should be avoided; (iii) labels should be non-intrusive, clearly legible, and properly differentiated from the other elements of the illustration; (iv) proportion and scale should be handled intelligently; (v) important information should be

<sup>235</sup>. Brodribb 1970; Ford 1993; Tufte 1990; Agrawala *et al.* 2011; Bertin 1983/2011.



emphasized, while irrelevant details should be de-emphasized or eliminated altogether; (vi) whole sets of information and different elements should be kept clearly distinct and differentiated, and (vii) the visualization should consider the viewer's perception and cognition of the information that is meant to convey.

The next couple of sections will consider a few examples from bookbinding illustrations and analyse whether these practical rules have been followed. Chapter 5 will cover more in details the set of general rules for an effective visual communication.

#### 4.5.1. SKETCHINESS AND DETAIL VIEWS

The use of sketches in published material could be considered an editorial choice. Nevertheless, a well-executed and regularly shaped illustration, not only looks more professional, but has also the ability of transmitting information more efficiently. Look for example at Figure 26 and Figure 27. Within the same publication, Szirmai<sup>236</sup> makes use of both well-executed and well-shaped drawings and sketchy free-hand ones. Note how clearer the sewing thread paths appear in examples [a] and [b] in Figure 26 as opposed to those in examples [c-h]. This situation becomes even more evident in the example in Figure 27 from Carvin's book.<sup>237</sup> Here the drawing appears as if it were executed directly on a drawing software with a mouse or similar device resulting in rather approximate shapes. On top of this, the author mixes schematic and more naturalistic elements in a confusing manner. For example, the gatherings are drawn as V-shaped with a single thin line representing the folds (as it was the case in Muzerelle's drawing in Figure 19[a]), thus leaving no space for the thickness of the gathering and of the thread. Because of all these problems, the drawing as a whole is rather difficult to interpret.

The use of sketches is clearly visible in the examples in Figure 28. Here the author<sup>238</sup> makes use of untidy line drawings, but she has also decided to use a scale

---

<sup>236</sup>. Szirmai 1999.

<sup>237</sup>. Carvin 1988.

<sup>238</sup>. Greenfield 1990.

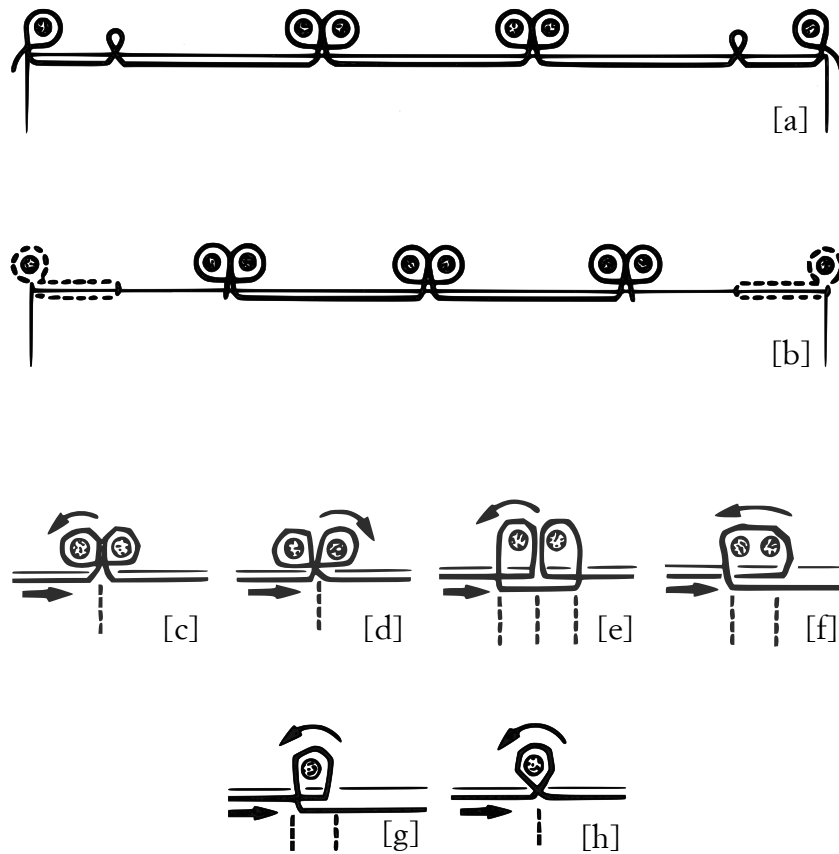

Figure 26. Well-shaped and free-hand thread paths. ([a-b] Szirmai 1999, fig. 9.8[c-d], p. 188; [c-h] Szirmai 1999, fig. 9.9[a-f], p. 189).

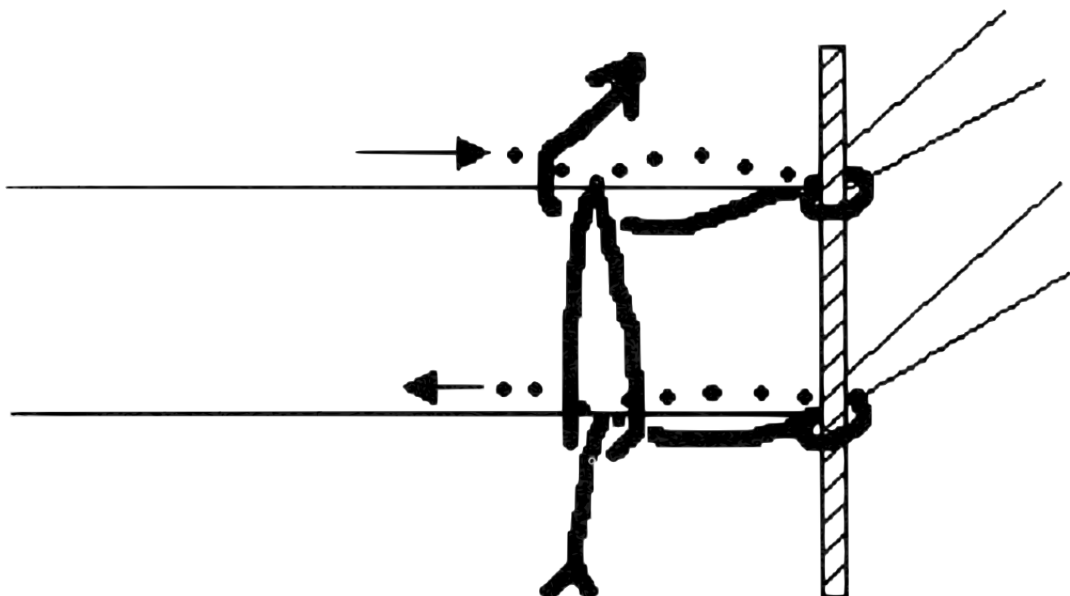

Figure 27. Drawing of an endband sewn at the frame executed directly on a computer in 1988. (Carvin 1988, p. 50).

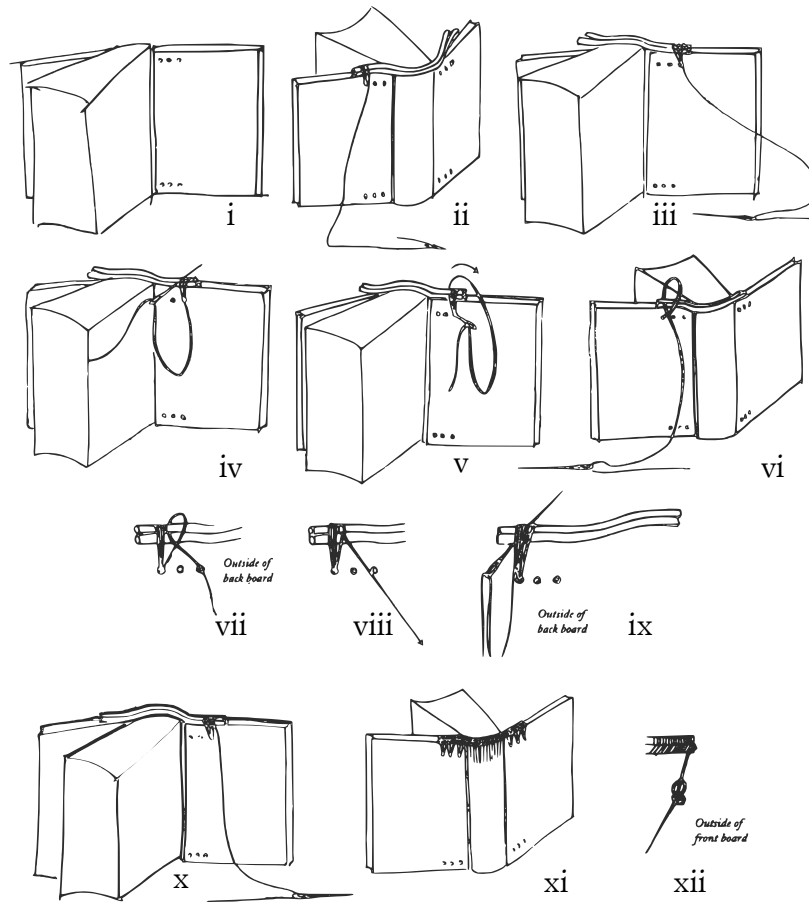

Figure 28. Sketch-like illustrations of the steps required to work a Greek-style endband. Note the untidy nature of the geometrical shapes, the choice of using a scale that portrays the whole binding for the majority of the steps, and the difficulty in distinguishing the different elements of the endband (compare with Figure 30). For this endband the author has decided not to make use of cross-section schematic illustrations to show the route of the thread around the cores, although such schematizations have been used for other endbands in the same book (see Figure 29). (Greenfield 1990, pp. 51-56).

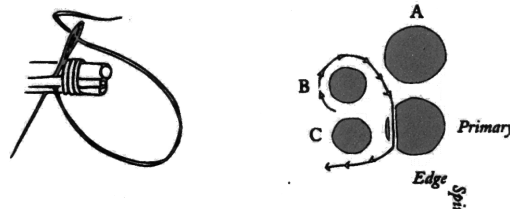

Figure 29. 'Step 11: go up around B and down behind cores B and C, coming back underneath them.' Here a step in the description of an Armenian-style endband sewing is illustrated by use of both a complex line drawing and a schematic line drawing. (Greenfield 1990, p. 61).

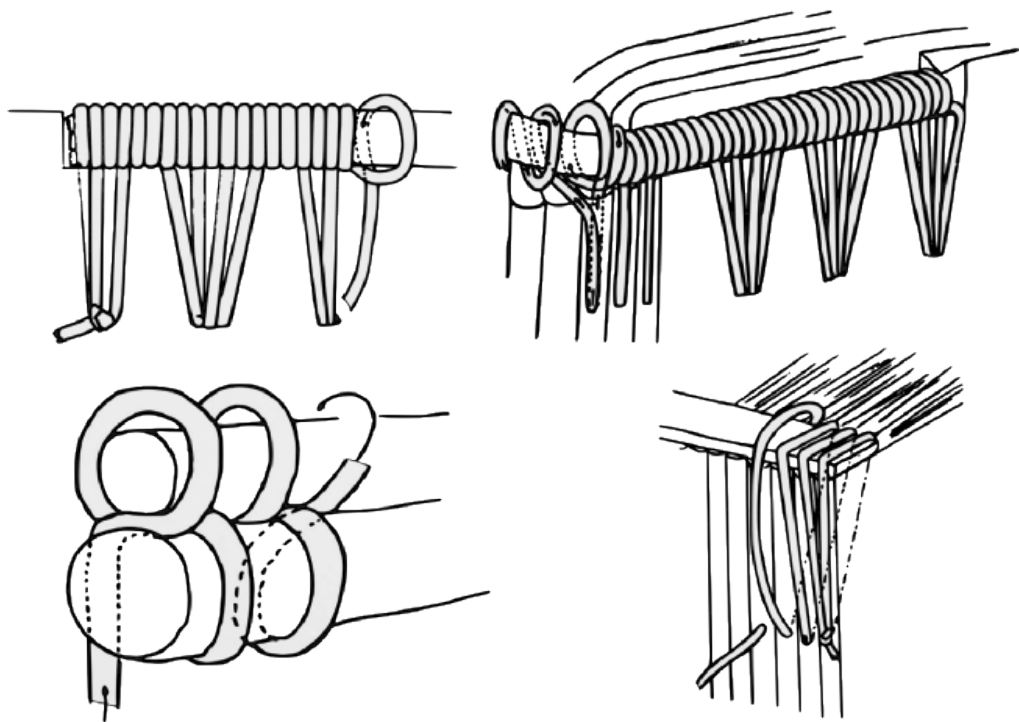

Figure 30. Line drawings of different styles of endbands. Note the use of regular and tidy shapes, the choice of using an appropriate scale that shows only a well-selected portion of the binding, and the ease of distinguishing the different elements of the endband. (Bibliothèque Nationale (France) 1989, pp. 59, 63, 87).

that portrays the whole binding for the majority of the steps illustrated for the working of a Greek-style endband. Because of this choice, the actual shapes that should illustrate the process are too small and confused to be followed by the reader. The reader of a manual on the sewing of endbands, it can be argued, would know where on a binding the endband should be sewn and therefore there is no reason to show the whole book.

Figure 30 shows another example of the sewing of a Greek-style endband taken from a different manual.<sup>239</sup> Here the authors have decided to employ regularly shaped line drawings using an appropriate scale that shows only a well selected portion of the binding. Note the ease of distinguishing the different elements of the endband.

<sup>239</sup>. Bibliothèque Nationale (France) 1989.

In the literature, therefore, one can see different styles of drawings, and these are sometimes not carefully executed or designed. Considering the importance of visual information for bookbinding structures, and the problems linked with natural language descriptions, this can lead to unclear and indeterminateness even with a multimodal approach that joins verbal and visual depictions.

The shapes to be generated for this project will aim at showing the minimum amount of information at a useful level of abstraction, just as verbal information should be provided at the correct semantic entry point to convey a useful level of information. Line drawings have been identified as the basic graphic level of abstraction. The aim is to be able to provide information visually in such a way that it can be easily compared between instances of structures belonging to the same category. Considering how three-dimensional representations tend to distort some details and shapes, making it less immediate to recognize similar patterns,<sup>240</sup> the drawings of choice will be simple line drawings. These will depict items through the most useful views, be this a general, or a detailed view, a cross-section, etc., or, in fact, a combination of views.

## **Summary**

Information on the elements and form of objects is best disseminated and analysed by means of a multimodal approach that capitalizes on the human ability to categorize information and to process visual information. Drawing is an important part of the surveying, recording, and description of bookbinding structures.

Bookbinding structures have been described in different ways in the literature. Of these, natural language appears to be unable to convey information that can be interpreted in only one way, creating interpretation problems unless associated with some kind of visual information that can aid in interpreting the spatial con-

---

<sup>240</sup>. Ferguson 1992; Ware 2013.

figuration of the components. Controlled vocabularies and structured descriptions instead seem to be able to provide spatial information in a more reliable manner.

Of the various kinds of illustrations found in the literature on bookbinding, line drawings, and in particular the schematic kind, appear to be a good choice as they are able to convey the necessary amount of information, while being simple enough to be readily interpreted, understood, and remembered.

These diagrams abstract the essential and hold a great deal of information for interpreting and categorizing bookbinding structures, and, at the same time, are easily referenced to and compared with other examples.

These diagrams show the elements that make up a certain object, the number of such elements, and their spatial arrangement, thus easily conveying also the object's form. Being schematic, they are straightforwardly enriched with symbols to deliver other kinds of information, like the material of certain elements, or functional information (by the addition of arrows).

The next chapter looks more in detail into the descriptions of material objects, and discerns which verbal descriptions are more suitable for an automated intersemiotic translation. It then considers the peculiarities of the visual language, and the relationship between a representation and the reality it refers to.

## Chapter 5. Communicating & translating objects

*La structure [...] est terrible. On ne peut la supplier, lui dire: «Voyez comme je suis mieux que H...» Inexorable, elle répond: «vous êtes à la même place; donc vous êtes H...» Nul ne peut plaider contre la structure.*

*The structure [...] is terrible. It can not be implored, saying: 'Look how I am better than H...' Inexorable, the structure replies: 'You are in the same place; therefore you are H...' No one can argue against the structure.\**

Roland Barthes, *Fragments d'un discours amoureux: Identifications*, 1977, pp. 154-155. \*Author's translation

This chapter looks into the languages involved in the project, and considers what kind of verbal description best conveys the relevant information so that it can be transformed into a diagrammatic visualization. The term *language* refers to any system of representation and communication,<sup>241</sup> and in this project the languages involved are both verbal and visual means of communication.

The first part analyses the examples of bookbinding structures described in the previous chapter and advances the reasoning for the selection of a structured description as the most useful model *of* the structures for this project. The second part looks at the implications of the transformation of information into a visual

---

<sup>241</sup>. Stenning & Lemon 1999.

language. The last part covers the issue of uncertainty in the data and in the visualizations.

## 5.1. Communicating material objects through verbal means

In chapter 3 we have seen how in order to be able to describe a material object, one has to be able to communicate its material components, its form, and its logical form. In order to be able to do so, one needs to understand the object completely,<sup>242</sup> i.e. to understand and predict all possible ways in which its components could be in relationship with one another.<sup>243</sup> This leads to important considerations in regard to the description of material objects.

In the previous chapter, three different kinds of verbal descriptions of book-binding structures were analysed: (i) natural language descriptions, (ii) controlled vocabulary descriptions, and (iii) structured descriptions with controlled vocabulary. The first is not capable of successfully conveying the form of the binding structure. Eide<sup>244</sup> describes a similar case for textual maps. He refers to this kind of description as *under-specified*, as based on such natural language descriptions, more than one map can be drawn, and often, these maps can be significantly different. In a similar way, Peirce<sup>245</sup> referred to the same concept of under-specification as the *development* of a sign: the meaning of a sign can be translated into some other sign in which it is more fully (or indeed, less fully) developed. In fact, for Peirce, an iconic sign does not necessarily have to be an image, but a verbal text can indeed have iconic characteristics, ‘but the icon is not clearly apprehended’,<sup>246</sup> as the passage of information from visual to verbal is less fully developed than in proper iconic signs. Natural language descriptions are thus under-specified and under-developed, leading to the generation of more than one possible interpretation.

---

<sup>242</sup>. Wittgenstein 1922/2012T: 2.01231.

<sup>243</sup>. Wittgenstein 1922/2012T: 2.0124.

<sup>244</sup>. Eide 2012a.

<sup>245</sup>. Peirce 1931-1935/1958: CP 5.594; Dewey 1946.

<sup>246</sup>. Peirce 1931-1935/1958: CP 7.467.



The second kind seemed to be a successful mode of communication, though only for linear structures whose sequential spatiality was mirrored in the sequential nature of the text. Structured descriptions with a controlled vocabulary, instead, with their inherent hierarchical structure and grouping of information might have the ability to describe binding structures successfully, and also for complex non-linear structures.

Controlled vocabulary descriptions, both alone, and within structured descriptions, try to rationalize what material components are found within a binding structure. By prescribing what kinds of components can be found within a certain binding structure through the selection of a precise set of terms, controlled vocabularies provide both the person describing such a structure, and the reader of the description, with all of the components that come together to form it. Also, by precisely defining each term, they try to provide all properties (or better those properties deemed important and/or essential) for each component. Therefore, by defining the elements of a material object and its properties, controlled vocabularies have the potential capacity to describe an object effectively, even for cases that are not yet encountered. 'If I know an object I also know all its occurrences in states of affairs. (Every one of these possibilities must be part of the nature of the object.) A new possibility cannot be discovered later'.<sup>247</sup>

#### 5.1.1. COMMUNICATING THROUGH CONTROLLED VOCABULARIES

Verbal communication is renowned for its difficulty in conveying spatial information. Words, because of their sequential nature, are not efficient in communicating non-linear spatiality.<sup>248</sup> Spatiality can be defined as the characteristic of reality to occupy space as an autonomous form of organization in which multiple distinguishable elements can coexist.<sup>249</sup> Spatiality and the structural interrelations of

---

<sup>247</sup>. Wittgenstein 1922/2012T: 2.0123.

<sup>248</sup>. Stenning & Lemon 1999.

<sup>249</sup>. Saint-Martin 1990.

elements within an entity are difficult to pin down through linear and sequential verbal communication.

Words, by working within a categorical labelling system are generally not well-suited to capture the specificity of an object.<sup>250</sup>

As seen in the analysis of related works in chapter 2, spatiality and specificity posed problems for most projects, when such information could not be gathered through means other than verbal communication. Of the cultural heritage projects, the one presented by De Luca and colleagues<sup>251</sup> seemed particularly interesting, as it was able to convey, through the use of the formal terminology of classical architecture, both information relating to the material components of the objects represented and their form.

The reason for the success of this project is surely to be found precisely in the fact that it was able to use as verbal input a very particular form of technical vocabulary. Goulette and Borillo<sup>252</sup> have researched architectural composition and the semantics of spatial expressions within the vocabulary of classical architecture. They have found that this technical vocabulary is able to convey spatial and structural information in the form of whole/part relationships, cognitive spatial relationships sustained by the functional information about the parts and the various objects, and on regular models of compositions. Together, this information can assist a model of spatial reasoning that is able to represent architectural information conveyed through verbal means. According to this model, the conceptualization of the spatiality of the elements is not limited to geometric aspects, but it is rather guided by considerations on the functional organization of each element and the relative disposition of its borders. The fundamental relationships of this model are: the relation of parthood ( $x$  is part of  $y$ ), and the relation of 'border of'<sup>253</sup> ( $x$  is the border of  $y$ ). Through the expression of these relationships, the understanding of the elements and their function, and of the rules of composition that are part of the architectural grammar controlling the relative positions

---

<sup>250</sup>. Stenning & Lemon 1999; Saint-Martin 1990.

<sup>251</sup>. De Luca *et al.* 2005; De Luca 2013.

<sup>252</sup>. Goulette 1999; Borillo & Goulette 2006.

<sup>253</sup>. Borillo & Goulette 2006, p.51.

of each class of elements, a verbal description is capable of conveying relative but adequate spatial and structural information.

Goulette<sup>254</sup> has also identified three types of entities in the vocabulary of classical architecture: the architectural elements, their spatial references and functions, and their geometric representation. Each term within this vocabulary is capable of conveying all of this information, as was seen in the case of the elements of the column profiles presented in chapter 2.

It would then seem that the use of a fully-developed controlled vocabulary can communicate enough information about a material object: its material components, its structural organization, its logical form, and its shape. The material components would be defined as terms, and the definitions would also be providing information on its function and, therefore, spatial references, and on its geometric representation; the rules of composition would function as a reference to its logical form.

Bookbinding terminology is not as well-developed, and it generally does not convey precise geometric representational information; nonetheless, controlled vocabularies have the potential to be powerful communication devices.

#### 5.III. NAMES AND PROTOTYPICAL MATERIAL COMPONENTS

Verbal communication of material objects and their components is based on names, and names are a type of sign.<sup>255</sup> These names can be defined, and when so, they are necessarily generalized concepts and therefore prototypical signs. As a consequence, these signs exhibit a certain degree of indeterminateness.<sup>256</sup> Prototypes, in fact, as seen in chapter 3, usually coincide with the basic level of abstraction within a category<sup>257</sup> and are, therefore, inclusive and general. It is from their inclusiveness that the indeterminateness arises in regard of their specificity, e.g. the specific shape of a material component. In addition, prototypical signs can only offer a *selection* of the properties of the object to which they refer.

---

<sup>254</sup>. Goulette 1999.

<sup>255</sup>. Sebeok 1994.

<sup>256</sup>. Wittgenstein 1922/2012*T*: 3.24; *T*: 5.522.

<sup>257</sup>. Rosch 1978.

The very essence of a controlled vocabulary is the definition of its terms. Therefore, a controlled vocabulary should aim at defining the simplest elements possible, so to reduce the indeterminateness to a minimum.

#### 5.1.1.2. SEWING STRUCTURE CONTROLLED VOCABULARY

Let us look again at the earlier controlled vocabulary example:

*Unsupported structure: chainpattern across spine: in-line, periodicfold pattern. There are 4 sewing stations — A is at the head and D is at the tail. 2 needles are used, each sewing between 2 stations — A & B or C & D. They sew independently but identically. Enter at A, continue-on to B, exit, dropto-the-outside, link, climb, enter at B, reverse, exit at A, dropto-the-outside, link, climb, change-over and enter at A of section 2.*<sup>258</sup>

As already stated, although this description uses a controlled vocabulary in an almost natural language setting, it is nonetheless capable of describing the motion of the thread required for a particular sewing structure. Its controlled vocabulary is used in an intelligent way. In fact, by developing the terminology in three levels, it gives an overall structure to the description. (i) It first defines the typology of sewing, (ii) then the general resulting sewing patterns, and (iii) finally the sewing layer. It provides spatial coordinates, and it names a series of actions to produce the sewing being described. More general terms are used to describe the complex object that is the overall sewing structure (levels i and ii), then other terms name simpler objects and place them in space within the structure. Of particular interest is the series of named actions: these in essence subdivide the complex object that is the sewing thread into a sequential series of sewing thread fragments in specific spatial configurations. The relations between objects are expressed through the *relation of concatenation*<sup>259</sup> within the sequential language of the description. What at first glance looked similar to a natural language sentence with heavy use of special terms, with closer analysis begins to look different. The very use of those special terms creates, in fact, a specific framework giving the description a semi-

---

<sup>258</sup>. Spitzmueller & Frost 1982; Spitzmueller 1982.

<sup>259</sup>. Stenning & Lemon 1999, p. 48.

structured character. The logical form of the sewing structure is mirrored in the precise use of the terms and in the natural sequentiality of the information being recorded, thus making it a useful mode of communication. In practice, however, what these descriptions lack is the querying capabilities inherent in the information recorded within databases.

### 5.1.2. COMMUNICATING THROUGH STRUCTURED DESCRIPTIONS

In order to describe a binding structure in any of its possible configurations, and to make this description fully communicable, one would not only need to convey information relative to its material components, but also be able to make direct reference to the logical form it possesses.<sup>260</sup> The canon of the rules of composition in classical architecture offer such a reference. There is no such canon for the composition of the elements of bookbinding structures.

The reference to the logical form of the binding structure, the *expression*, is what is lacking in non-structured descriptions, besides the fact that in non-structured descriptions spatiality beyond linearity is not easily conveyed. Two non-structured descriptions of the same reality do not have the same expression in common and do not form a class as they do not have a way to refer to exactly the same logical form. In fact, as seen in the natural language examples in the previous chapter, even two non-structured descriptions of the same state of affairs do not necessarily possess the same expression. Because of this, their sense can be, and usually is, lost, unless the verbal description is coupled with a graphic description, whose elements correspond to the objects of the state of affairs being described: it is the graphic description that preserves a reference to the logical form, and can function as a medium between the logical form of the state of affairs and the form of the verbal description.

Controlled vocabularies instead are able to contain the building blocks of a complete description of a material object. Structured descriptions differ from simple controlled vocabularies. It is this difference that provides the description

---

<sup>260</sup>. Wittgenstein 1922/2012T: 3.34; T: 3.341; T: 4.0141.

with a more complete representation of the logical form and its inherent possibility to indicate any form. Structured descriptions, although still relying on controlled vocabularies for the communication of objects, present information in an orderly and prescribed manner. The schema, the grammar of the information, ruling structured descriptions within databases is a manifestation of the *expression* and, when properly developed, mirrors the logical form of the material object it describes.

Within structured descriptions, information is organized into hierarchies that follow the logical structure of what is being described; within these hierarchies, information is organized into groups that bind relevant data together, and that form boundaries between entities.<sup>261</sup> The hierarchical organization expresses the association between parts<sup>262</sup> and this preserves a reference to the logical form of the state of affairs, and the configuration of objects within states of affairs.

The inclusion of controlled vocabularies within structured descriptions strengthens their communication capabilities. Whole/part relationships and functional/structural information can be encoded within the structure of the descriptions themselves, and the schema behind them maintains a reference to the logical form of the object just as much as classical architecture's rules of composition.

Controlled vocabularies and structured descriptions offer a well-developed mode of communication, in relation to the building blocks of material objects. These descriptions, if based on a model *for*, are also potentially *fully-specified*<sup>263</sup> as they can provide precise measurements and spatial relationships, just as a fully-specified description of a map would provide precise coordinates for every element to be drawn. This is not the case when they are based on models *of*. As seen, these models describe the idea of an object in reality and they strive to capture its logical form, and only relative information on the positioning of elements and their measurements are preserved (the logical form of a class of objects is applicable to all examples of that class and precise measurements are exclusive not inclusive).

---

<sup>261</sup>. Salthe 1985; Brachman & Levesque 2004; Gnoli 2008.

<sup>262</sup>. Pazzi 1999; Doerr *et al.* 2001.

<sup>263</sup>. Eide 2012a.

This leads to *under-specification*, but, as seen in the case of the vocabulary of classical architecture, not to the level that conflicting drawings would be generated. The outcome would be *under-specified* in the sense that as it is based on prototypical information, it would be inclusive and able to represent all items of its category, and not only one specific case. This is a different level of specificity that was not encountered by Eide,<sup>264</sup> since a prototypical map would be a useless map.

As mentioned in the previous chapter, a good example of a structured description and controlled vocabulary for bookbinding structures published to date is the description schema developed by *Ligatus* for the survey of the printed books in the library of the monastery of St. Catherine on Mount Sinai. The schema will be presented in more detail in the following chapter. This model of binding structures, being hierarchical and based on a controlled vocabulary, should be able to communicate the minimum amount of information necessary to communicate information on bookbinding structures. In turn, this information should be able to be transformed into diagrammatic visualizations of the structures.

### 5.1.3. DIAGRAMS AS SUPPORT FOR NATURAL LANGUAGE DESCRIPTIONS

In diagrammatic representations of material objects, each element stands in relation to other elements, and this configuration mirrors that of the material components of the object that is being represented. These relationships are embedded within the two-dimensional structure of the diagram, without the need for complex syntax.<sup>265</sup> In written and spoken language, because of their innate sequentiality, the expression of such relationships can prove challenging as they would need to be based on a complex syntax to compensate for their limited sequential nature.<sup>266</sup> The relationships are in fact not nameable elements, but manifest themselves in the configuration of the elements.

---

<sup>264</sup>. Eide 2012a.

<sup>265</sup>. Stenning & Lemon 1999.

<sup>266</sup>. Shin *et al.* 2013.

This explains why verbal descriptions of bookbinding structures accompanied by diagrams are capable of expressing spatiality: even when these are unstructured and make strict use of natural language, their accompanying graphic descriptions act as medium between the logical form of the state of affairs and the verbal description, preserving the reference to the logical form of the state of affairs.

## 5.2. Automated intersemiotic translations

This project is a clear case of intersemiotic translation.<sup>267</sup> from verbal to visual language.

In order to translate a proposition A in one language into a proposition B in another, one needs to establish rules of definition and correlation between the two expressions.<sup>268</sup>

As seen in the communication of material objects, one needs to convey information regarding the material components and their form, and to maintain a reference to their logical form. In addition, for visualization purposes, one also needs to be able to generate a prototypical shape for the objects and their components. In a translation process the same information needs to be conveyed and transformed into the target language. For this project, the transformations also have to be programmable in advance through transformation algorithms capable of capturing the necessary information and then transforming it into visual representations.

### 5.2.1. TRANSLATING MATERIAL COMPONENTS, THEIR FORM, AND SHAPE

Material components are translated by transforming the components of the proposition A into the components of proposition B in such a way that the signs that represent a component in language A possess a meaning that is common to

---

<sup>267</sup>. Jakobson 1959. See also chapter 1.

<sup>268</sup>. Wittgenstein 1922/2012*T*: 3.343; *T*: 4.0141.



all signs that can be substituted to them in a proposition B belonging to any other language.<sup>269</sup>

In practice, therefore, an algorithm can be programmed in such a way to establish a one-to-one relationship between the components of the verbal descriptions and those of the visual representations. For each descriptive element in proposition A, something needs to be drawn in proposition B. However, this is not as straightforward as it might seem. As covered in chapter 3, in visual texts, sememes are interdependent, and by simply establishing a one-to-one text-to-picture relationship without considering the nature of the visual language, one risks generating nonsensical and unstructured agglomerates of visual signs, like those proposed by Zhu and colleagues.<sup>270</sup>

### 5.2.2. TRANSLATING MATERIAL OBJECTS' SHAPES

In a similar way, for each component in A, one should establish a shape that its sign will take in proposition B. Through a one-to-one relationship between the components, an algorithm could be designed to generate a prototypical shape for each material component. This is possible because, as seen, verbal prototypes at the basic level of abstraction are associated with a mental image that resembles the appearance of members of the class as a whole.<sup>271</sup> It is therefore feasible to prescribe a shape that is derived from the mental image for each component. However, once again, the very nature of visual signs imposes that careful consideration is given to the generation of the shapes, as these are likely to depend on those of the other signs within the visual text. To accommodate this, shape generation should be parametrized, i.e. it should use the relationships between components as shape forming parameters.<sup>272</sup>

---

<sup>269</sup>. Wittgenstein 1922/2012T: 4.025; T: 3.344.

<sup>270</sup>. Zhu *et al.* 2007.

<sup>271</sup>. Rosch 1978.

<sup>272</sup>. Monedero 2000. See also Davis 2013, chapter 2, pp. 14-48.

### 5.2.3. TRANSLATING AN OBJECT'S FORM

Information on an object's form, as seen, can be conveyed through the use of controlled vocabularies. The mental images triggered by verbal prototypes possess structural and spatial characteristics<sup>273</sup> that can be rendered graphically to depict the form of the object. In addition, the hierarchical nature of the information within structured descriptions is also capable of conveying spatial information. This will be seen in more detail with practical examples in chapter 7.

In practical terms, the hierarchical organization of the information can be interpreted by the algorithm as spatial relationships between components, just as relative positioning derived from the definition of the controlled vocabulary entities. This information resembles that highlighted by Goulette and Borillo<sup>274</sup> for architectural vocabulary. Basic information is the relation of parthood ( $x$  is contained in  $y$ ), the relation of concatenation ( $x$  follows  $y$ ), and the relation of border ( $x$  is a border of  $y$ ). Combined, these relationships can express the relative spatiality of the parts. The orientation is derived from the general rules of composition of the domain.<sup>275</sup>

### 5.2.4. THE REFERENCE TO THE LOGICAL FORM

A reference to the logical form of the object is an important part of the communication process about material objects. Without it problems can occur. In automated intersemiotic translation of the kind described in this project, this reference, embodied in the schema, is a necessary component of the process. The schema informs the coding of the transformation algorithms, as it prescribes which components are parts of the object described, and in which spatial configurations these can occur. Without this, the problem would essentially turn into natural language parsing, attended by all the complexities described in chapter 2.

---

<sup>273</sup>. Thomas 2013.

<sup>274</sup>. Goulette 1999; Borillo & Goulette 2006.

<sup>275</sup>. Goulette 1999.

For this reason, structured descriptions are an ideal verbal description modality. The following chapters will analyse and assess this intersemiotic translation process from structured verbal descriptions of bookbinding structures to diagrammatic visualizations.

The following part of the chapter delineates those general considerations that are necessary for a visual language attempting to represent material objects.

### 5.3. Communicating material objects through visual means

As already discussed in chapter 3, diagrammatic representations, unlike most sentence-based representation systems, i.e. sequential languages,<sup>276</sup> function within systems of representation that are specific to a target domain, i.e. that which is to be represented.<sup>277</sup> That is to say that the signs to be used depend on what is to be represented, and this is even more so the case in highly iconic representations.

This does not mean that general, meta-domain considerations cannot be drawn. In fact, despite the arbitrariness of the signs specific to a language, a particular mode of signifying something is unimportant. What is important is that it is a *possible* mode of signification that is able to convey the essential.<sup>278</sup>

It is, in fact, possible to draw a set of general guidelines or design principles that, by understanding how perception and cognition of visual information affect comprehension of the information presented to the viewer, prescribe how to communicate information effectively through visual means.<sup>279</sup>

The following sections will cover the most important considerations for an effective visual language. The following chapters and Appendix B will cover the domain-specific visual language developed for this project.

---

<sup>276</sup>. Stenning & Lemon 1999.

<sup>277</sup>. Stenning & Lemon 1999.

<sup>278</sup>. Wittgenstein 1922/2012 *T*: 3.342; *T*: 3.3421.

<sup>279</sup>. Ford 1993; Tufte 1990; Tufte 1997; Tufte 2001; Tufte 2006; Agrawala *et al.* 2011; Bertin 1983/2011; Ware 2013.

### 5.3.1. MARKS ON A BACKGROUND

Chapter 3 shows how line drawings are sufficient to understand a shape, and that these are prototypical enough to be used as graphical prototypes. Also, for these reasons, line drawings present the maximum amount of data with the least amount of *ink*, thus following Tufte's<sup>280</sup> data-ink ratio maximization principle for graphic excellence.

Line drawings, in essence, are arrangements of linear marks on a white or neutral background. These marks are the elements of a proposition, and, as such, they can be sensed<sup>281</sup> and sensed specifically through vision.

Visual perception of line drawings and diagrams allows for a total of three dimensions that can be used to encode information: (i & ii) the two dimensions of the plane, and (iii) the possible variation of the marks.<sup>282</sup> Bertin<sup>283</sup> identifies eight possible variables in total. Bertin differentiates between *spatial* and *retinal* variables. Spatial variables are the two dimensions of the plane identifying the spatial position of a mark. Bertin refers to the possible variations of the marks as retinal variables because they are perceptually salient features that do not require eye movement to be identified, and they must, therefore, be realized in the retina. Neuropsychology studies have identified that these features are linked to the firing of specific neurons within the visual areas 1 (V1) and 2 (V2) of the cortex after preliminary processing in the retina.<sup>284</sup> Bertin distinguishes between six retinal variables: size, texture, grey value (or lightness), colour (or hue), orientation, and shape. Psychophysics, the study of human responses to physically defined stimuli, have identified more visual features that make items stand out and easy to find.<sup>285</sup> For static bi-dimensional percepts, Ware<sup>286</sup> lists: line length and width, curvature, spatial grouping and numerosity, sharpness/blur, and the addition of marks or halo.

---

<sup>280</sup>. Tufte 2001, pp. 123-138.

<sup>281</sup>. Wittgenstein 1922/2012T: 3.1.

<sup>282</sup>. Bertin 1983/2011.

<sup>283</sup>. Bertin 1983/2011.

<sup>284</sup>. Ware 2008; Ware 2013.

<sup>285</sup>. Findlay & Gilchrist 2005; Ware 2008; Ware 2013.

<sup>286</sup>. Ware 2008; Ware 2013.

### 5.3.2. CONTINUITY OF THE PLANE

Bertin<sup>287</sup> describes the plane on which visualizations are drawn as the richest of the variables, as any mark has to fall on it. One can distinguish between signifying and non-signifying parts of the plane: the former are intended to convey meaning, and they exclude the latter, which are formed by the space lying outside of graphic boundaries — e.g. a geographical border or the frame of a drawing — and are, therefore, not meant to carry any information. It is possible to have nested (or layered)<sup>288</sup> signifying planes, but the nesting has to implement the Gestalt principles<sup>289</sup> of proximity, closure, and common region carefully to allow for the correct regions to be regarded as non-signifying.

The signifying plane is continuous as it can be infinitely subdivided by marks applied on it. As such, it does not admit gaps, informational lacunae, as the absence of signs, or *zero signs*,<sup>290</sup> is read as absence of phenomena, and not as missing data: it is difficult to disregard part of the signifying plane.<sup>291</sup>

Therefore, in visualizations, it is important not to leave gaps in the signifying parts of the plane, or the risk is to alter the meaning of the visualization, or to render it meaningless. This also applies to the way in which boxes and edges are used and designed: the balance between the signifying and the non-signifying parts of the plane always has to be kept in mind.

### 5.3.3. VISUALIZATION CONVENTIONS

Graphic languages utilize all of the above-mentioned variables to communicate information. In the literature, general studies on graphic languages tend to focus on the visualization of quantitative or geographical data (i.e. cartography), histor-

---

<sup>287</sup>. Bertin 1983/2011.

<sup>288</sup>. Ware 2008; Ware 2013.

<sup>289</sup>. Koffka 1935.

<sup>290</sup>. Sebeok 1994.

<sup>291</sup>. Bertin 1983/2011.

ical data, and Geographical Information Systems (GIS) data.<sup>292</sup> Bertin<sup>293</sup> and Moretti<sup>294</sup> distinguish between three main categories of graphics: diagrams or graphs for quantitative data, networks or trees for qualitative data that can be arbitrarily arranged on the plane, and maps for geographic or cartographic visualizations. To these categories, Bertin<sup>295</sup> adds symbolic visualizations (i.e. symbols) that can be used within all of the above categories.

The diagrammatic visualizations needed for this project do not fall precisely within any of these categories. They are, however, closely related to strictly geographic and qualitative maps (less so with quantitative cartographic visualizations). In qualitative geographic maps, the position on the plane and the visual features of the representations are imposed by the nature of the data to be recorded: a city has to be placed at the right point on the plane that corresponds with its geographical coordinates, and a river has to follow the same path on the plane followed by its counterpart in the real world. In the same way, the position of a sewing support has to be relative to that of the other elements represented with it — e.g. the fold of the gathering — and the appearance of the sewing thread path should represent the path of the sewing structure being visualized. For this reason, it is possible to draw general concepts of visualizations from these partially pertinent studies. However, the restrictions imposed by the iconic nature of the visualizations always have to be kept in mind.

#### 5.3.3.1. FIXING MEANING THROUGH A REFERENCE SYSTEM

Chapter 3 highlights how visual information needs to be fixed by a referencing system for its meaning to become apparent. This can be accomplished by presenting it with a dual modality that combines word labels with the graphics. Also, the meaning of the elements of visual texts depend on their context. For these reasons, it is always important to present visual information within a well-

---

<sup>292</sup>. For example: Bertin 1983/2011; Tufte 1990; Tufte 1997; Tufte 2001; Tufte 2006; MacEachren 1992.

<sup>293</sup>. Bertin 1983/2011.

<sup>294</sup>. Moretti 2005.

<sup>295</sup>. Bertin 1983/2011.

developed referencing system that allows for the identification of the correct meaning of the overall graphic and of its elements.

#### 5.3.3.1.1. *TITLING AND VERBAL LABELLING*

Titles and other verbal labels allow fixing the meaning of a visualization. They permit the reader to identify, the general category of what is being represented — e.g. an endleaf structure — and to identify, in the drawing, those elements that can vary from example to example within the same category — e.g. from one endleaf structure to another.<sup>296</sup>

#### 5.3.3.1.2. *GRAPHIC REFERENCE ELEMENTS*

Previously, it was concluded that there has to be a one-to-one relationship between the components of verbal propositions and those of their visual translation. However, considering the need for contextualization of visual elements, it is appropriate to add reference elements within a visualization to help put each element of the structure in context visually, thus facilitating the signification of all other elements. For this reason, certain elements taken for granted or simply not mentioned in a description need to be made explicit within the visual representation of what is being described. These can be made less visually prominent to differentiate them from important information. For example, endband cross-section diagrams, as it will be seen in the following chapter, include the bookblock on which the endband is attached as a visual reference element.

#### 5.3.3.2. *SEPARATION OF INFORMATION*

The basic rule for the generation of graphics with a high degree of legibility is to separate information into discernible visual groups. This is attained by balancing graphic density by avoiding too many marks per unit area and by keeping mean-

---

<sup>296</sup>. Bertin 1983/2011.

ingful marks visually separate.<sup>297</sup> The same considerations are valid for different views, sections, and boxes within a visualization.<sup>298</sup>

A consequence of the separation of information might be that the naturalism of the representation needs to be reconsidered. Effective graphic representations should always strive for best legibility, and correct signification, even at the expense of naturalism, by allowing that content and form of the visualization correspond to those of the desired mental representation (*principles of congruity*<sup>299</sup>) and that visualizations are readily and correctly perceived and understood (*principle of apprehension*<sup>300</sup>).<sup>301</sup>

### 5.3.3.3. USE OF COLOUR

Colour is an excellent selective variable that is able to make information immediately distinguishable. However, it does have two main drawbacks: (i) anomalies in chromatic perception (e.g. colour blindness) are more frequent than it is generally believed,<sup>302</sup> and (ii) inaccurate colour reproduction.

From a neuropsychological point of view, colour perception as it is analysed in the V1 area, can be subdivided into three information channels: the red-green channel, the yellow-blue channel, and the black-white (or luminance) channel. Luminance differences are calculated simultaneously between all adjacent areas of the retina, and not from the output of a selection of specific cones as is the case with the other channels. This justifies the greater capacity of the luminance channel to convey detailed information as opposed to the other channels. Also, colour blindness does not impede the perception of grey-scale values (and colours that differ in the yellow-blue direction).<sup>303</sup>

---

<sup>297</sup>. Bertin 1983/2011.

<sup>298</sup>. Ford 1993.

<sup>299</sup>. Tversky 2005b, p. 29.

<sup>300</sup>. Tversky 2005b, p. 29.

<sup>301</sup>. See Chapter 3. Tversky 2005b; Tversky 2006.

<sup>302</sup>. About 8% of males and 1% of females are colour blind (Ware 2008).

<sup>303</sup>. Ware 2013.



There are also significant problems involved with colour reproduction from one medium to another, and the more information depends on a hue-specific colour coding, the more expensive the reproduction will be.<sup>304</sup>

Hue variations as carriers of specific meanings should only be used when indispensable. The diagrams generated for this project will therefore make use of black and white or grey-scale graphic elements.

#### 5.3.3.4. TWO-DIMENSIONAL VS. THREE-DIMENSIONAL VISUALIZATIONS

The problem with three-dimensional representations is that they make it harder to compare the features and forms of similar items. Human pattern perception is for the most part devoted to planar information as opposed to depth.<sup>305</sup> Also, whilst three-dimensional views seem to deliver information in a more direct way, in reality, all shapes are in fact distorted — e.g. circles are ellipses, rectangles show no right angle and no equal sides — and this can lead to ambiguity.<sup>306</sup> Two-dimensional views are better suited to facilitate the comparison of features between different examples.<sup>307</sup>

#### 5.3.4. STRUCTURED VISUALIZATIONS AS OUTPUT

The final output of this project is a series of automatically generated drawings. Each drawing is the result of a direct translation of the description of a material object. As mentioned above, in order for the translation to be appropriate, there has to be a one-to-one relationship between the components of the propositions in the two languages. This is self-evident, when the two languages have similar kinds of expressions, as in the case of intralingual and interlingual translations.<sup>308</sup> When dealing with intersemiotic translations, however, this might not be evident.

---

<sup>304</sup>. Bertin 1983/2011; Ware 2013.

<sup>305</sup>. Tversky 2001; Tufte 2001; Ware 2008; Ware 2013.

<sup>306</sup>. Ferguson 1992.

<sup>307</sup>. Ferguson 1992; Ware 2013.

<sup>308</sup>. Jakobson 1959.

Let us consider again the nature of information shown in images. Images feature on a plane, which is continuous in nature and capable of infinite subdivisions.<sup>309</sup> Images are continuous entities that can be subdivided in smaller elements within their plane, but these are not always clearly discernible from one another. Images can then be seen as macroscopic blocks of information, within which it is possible to identify pertinent units.<sup>310</sup> These units are the visual sememes of the visual message encoded in the image. These units are also the elements of the visual proposition corresponding to the elements of the object being depicted. They stand in the same one-to-one relationship with reality as the elements of verbal descriptions, and this is also the basis for the one-to-one relationship between the two propositions in the two different languages.

Unlike verbal propositions, however, the units of images are seldom discreet with clear boundaries. They can thus be generated in accordance to the one-to-one relationship with the elements of the verbal description — i.e. for each element, something can be drawn — but their final shape will generally depend on that of the adjacent units, and this parametrization of the shapes will need to be taken into account by the intersemiotic translation algorithm. This way, in a combinatorial way, the whole image text can be constructed element by element within a structured visualization system. *Structured* as the resulting drawing, while appearing as one (or sets of macro-groups, e.g. different views of the same item), has a clear internal organization and arrangement of its parts.<sup>311</sup>

The next chapter will cover this in more detail when looking at the practical application of these principles.

## 5.4. The uncertainty of reality

In reading or seeing a verbal or visual representation of an object and when comparing it to the real object, one can ascertain whether the representation is

---

<sup>309</sup>. Bertin 1983/2011.

<sup>310</sup>. Eco 1975/2008; Saint-Martin 1990.

<sup>311</sup>. Wittgenstein 1922/2012T: 5.5423.

true or false, and the feedback to reality is actually the only way to be certain of the truthfulness or falsehood of a proposition.<sup>312</sup> Certainty is what makes it possible to distinguish between truthfulness and falsehood, and its essence is in the action of seeing that something is (or is not) the case. That is to say that a proposition is only true or false in respect of what it represents. Certainty is an act of judgement of what a proposition shows about reality, and propositions should make our judging explicit. A judgement is correct only if the proposition judged is true.<sup>313</sup> Reality is usually not so clear-cut: there are degrees of certainty about its truth, because uncertainty pervades the world in which we live.<sup>314</sup>

In particular, when dealing with material objects such as historical bookbinding structures and their visualization, one has to accept that a degree of uncertainty is inevitable.<sup>315</sup> There are many and various definitions of uncertainty,<sup>316</sup> but in general, all definitions imply imperfection of the knowledge about the dataset, or in the representation of knowledge.<sup>317</sup>

Brodlie and colleagues,<sup>318</sup> distinguish between two problems related to uncertainty in visualization: (i) that of the *visualization of uncertainty*,<sup>319</sup> and (ii) the problem of the *uncertainty of visualization*.<sup>320</sup> In answer to the former problem, one has to deal with how to depict the uncertainty specified within the data to be visualised. The latter problem instead rests in the inaccuracy that occurs in the process of turning the data into a picture.

Therefore, a system that attempts to describe and represent reality has to address, on the one hand, the problem of propositions that are neither completely true nor completely false<sup>321</sup> — i.e. to address the problem of the uncertainty within the data — and, on the other hand, has to consider that the very process

---

<sup>312</sup>. Wittgenstein 1922/2012T: 2.21; T: 2.222; T: 2.223; T: 2.224.

<sup>313</sup>. Wittgenstein 1969; Stoutland 1998.

<sup>314</sup>. Gabbay & Smets 1998; Zuk 2008.

<sup>315</sup>. Campagnolo & Velios 2013.

<sup>316</sup>. Thomson *et al.* 2005.

<sup>317</sup>. Thomson *et al.* 2005.

<sup>318</sup>. Brodlie *et al.* 2012.

<sup>319</sup>. Brodlie *et al.* 2012, p. 82.

<sup>320</sup>. Brodlie *et al.* 2012, p. 82.

<sup>321</sup>. Gabbay & Smets 1998.

of translating data into a visual representation can produce problems with accuracy.<sup>322</sup>

The inclusion of uncertainty in a system, however, is not an easy task.<sup>323</sup> Uncertainty is a complex phenomenon. Thomson and colleagues<sup>324</sup> have proposed a typology about uncertainty of geospatial information subdivided into nine categories (accuracy/error, precision, completeness, consistency, currency/timing, credibility, subjectiveness, interrelatedness, lineage), which has been further analysed and generalized by Zuk and Carpendale.<sup>325</sup> Of these categories, the most important ones for the project at hand are: (i) accuracy — the difference between the observation and reality, (ii) precision — the exactness of measurement, and (iii) completeness — the extent to which the information is comprehensive.<sup>326</sup>

Uncertainty is propagated when we operate with uncertain data. And uncertainty in the data also needs to be propagated as uncertainty in the graphic output. As the original data is transformed into a visualization, uncertainty follows, and a reference to the uncertain data must be maintained. Also, uncertainty adds a visual dimension to the visualization, and this dimension needs not to have already been used.<sup>327</sup>

Most visualization techniques traditionally have been developed, and used, with the assumption that the visualized data is certain. Also, most people have a tendency to treat visualized data as facts, and are much less prone to question visualizations than written words.<sup>328</sup> This, in turn, can lead to problems in the reading of visualized data, as ‘one can *draw inferences* from a false proposition.’<sup>329</sup> Tufte<sup>330</sup> brings forward examples of how improper visualizations historically have misled the interpretation of the original data.

For all these reasons, both uncertainty in the data and the uncertainty inherent in the visualization medium need to be taken into account and signalled.

---

<sup>322</sup>. Brodlie *et al.* 2012.

<sup>323</sup>. Brodlie *et al.* 2012.

<sup>324</sup>. Thomson *et al.* 2005.

<sup>325</sup>. Zuk & Carpendale 2007.

<sup>326</sup>. Thomson *et al.* 2005; Zuk & Carpendale 2007.

<sup>327</sup>. Brodlie *et al.* 2012.

<sup>328</sup>. MacEachren 1992; MacEachren *et al.* 2005; Brodlie *et al.* 2012.

<sup>329</sup>. Wittgenstein 1922/2012T: 4.023.

<sup>330</sup>. Tufte 1997.

#### 5.4.I. UNCERTAINTY IN STRUCTURED DESCRIPTIONS

In the first instance, the data to be visualized has to be able to convey information in respect of its certainty. In a description, a particular object can be present or not, or it can correspond to a certain prescribed type or not. This seems simple enough, however, there are many reasons why the reality of material objects cannot be easily and completely described by yes or no answers: yes there is such and such object, no there is not; yes this is such and such object, no this is not.

As in the case of quantitative and geographical data visualizations,<sup>331</sup> factors of uncertainty can be found in inherent problems with the definition of the object of study — e.g. the limitations of current knowledge regarding bookbinding structures and their description — or the sources of information and their interpretation — e.g. the books being described and the interpretation of their binding structures. Moreover, it might not be possible to completely describe a material object — e.g. a book is sometimes too damaged to show clear evidence of its original structure, or else, elements of the binding might not be physically visible — e.g. spine linings — and, therefore, describable.<sup>332</sup>

A description system has to be able to accommodate such cases. Structured descriptions can allow for three- or multi-valued logic to be embedded within their schema, thus allowing for more than just yes or no answers. Multi-valued logic differs from the more commonly known bivalent logic — e.g. classical or Boolean logic — as it does not restrict the number of truth values to only two: true or not-true (false). The simplest version of this kind of logic, three-valued logic, provides for three possible answers to the truthfulness of a proposition: true, unknown, false.<sup>333</sup> The simple addition of the *unknown* truth value can be used to express uncertainty, and this is easily implemented within structured descriptions. For example, in describing a bookbinding, for the aforementioned reasons, one might not be certain whether the book has a certain type of spine lining: saying that *yes* it has a certain type of spine lining would introduce poten-

---

<sup>331</sup>. Wilkinson 2005; Wainer 2009; Gethin Powell 2012.

<sup>332</sup>. Campagnolo & Velios 2013.

<sup>333</sup>. Gottwald & Anat 2014.

tially erroneous data into the dataset, but so would the opposite. By offering the possibility of saying that the type of spine lining is *unknown* permits one to express the uncertainty of the information: yes, there is a spine lining, but one cannot say for certain which type of spine lining was used on that particular binding.

#### 5.4.2. UNCERTAINTY IN VISUALIZATIONS

In the literature, there have been many and various attempts to include uncertainty within visualizations in a diverse range of fields: from astrophysics to meteorology, geography, and archaeology, to mention but a few.<sup>334</sup> The importance of uncertainty was historically first realized by the geovisualization community,<sup>335</sup> followed by the scientific visualization community.<sup>336</sup> General reviews on the problem can be found in the contributions by Wilkinson,<sup>337</sup> Griethe and Schumann,<sup>338</sup> Zuk and Carpendale,<sup>339</sup> Zuk,<sup>340</sup> and Brodlie and colleagues.<sup>341</sup>

##### 5.4.2.1. ARCHAEOLOGICAL VISUALIZATIONS

Of the various fields that use visualization as research output or tool, and communication, archaeology appears to be the closest to that of this project: both archaeology and the archaeology of the book deal with material objects as their data, be this a temple or a book.

---

<sup>334</sup>. Brodlie *et al.* 2012.

<sup>335</sup>. MacEachren 1992; Goodchild *et al.* 1994; Pang 2001; MacEachren *et al.* 2005; Brodlie *et al.* 2012.

<sup>336</sup>. Pang *et al.* 1997; Thomson *et al.* 2005; Wilkinson 2005; Brodlie *et al.* 2012.

<sup>337</sup>. Wilkinson 2005.

<sup>338</sup>. Griethe & Schumann 2006.

<sup>339</sup>. Zuk & Carpendale 2006; Zuk & Carpendale 2007.

<sup>340</sup>. Zuk 2008.

<sup>341</sup>. Brodlie *et al.* 2012.

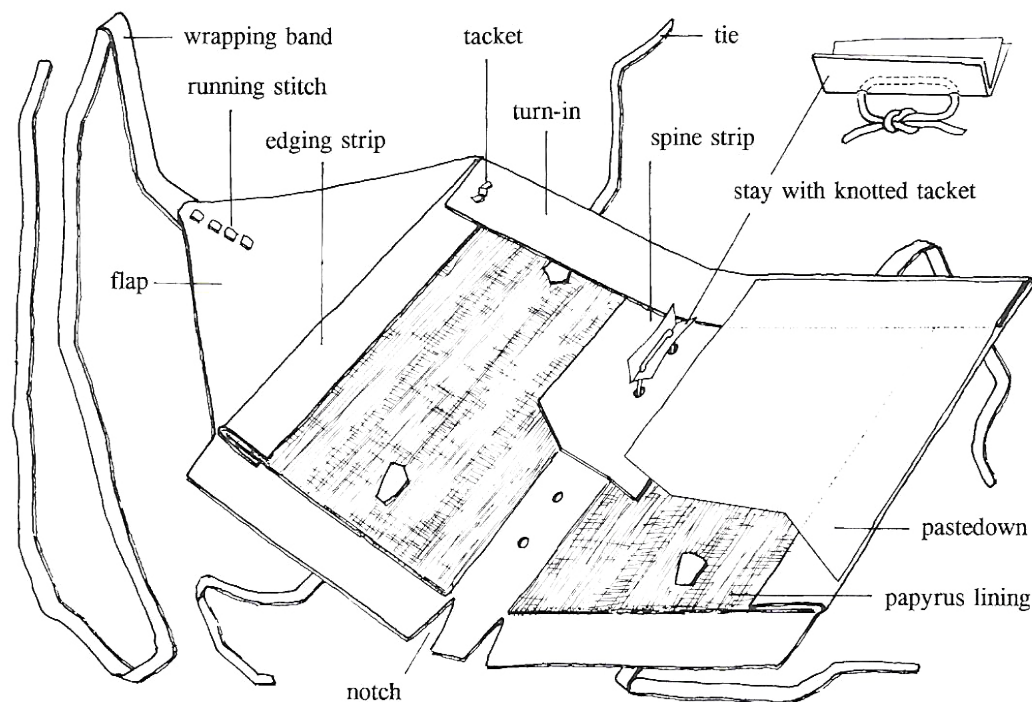

Figure 31. Diagram of the construction of the Nag Hammadi codices (Szirmai 1999, fig. 1.2, p. 8).

#### 5.4.2.1.1. AN EXAMPLE FROM ARCHAEOLOGY OF THE BOOK

Archaeological datasets are often incomplete and ambiguous.<sup>342</sup> Notwithstanding this, visualizations of archaeological sites or objects more often than not tend towards single holistic photorealistic images.<sup>343</sup>

The same idea of one fixed and certain visualization of how a bookbinding looked can be found in studies of the archaeology of the book. An example is the case of the notorious Nag Hammadi Codices. These are a series of thirteen papyrus codices, dating from the third-fourth century AD, and amongst the earliest examples of surviving structures of books in the codex form. They were found still in their original leather bindings in 1945, buried in a jar near the Nag Hammadi village in Egypt. The discovery was announced in 1949<sup>344</sup> and in the same year a short article with a few general photographs of the manuscripts was published,<sup>345</sup> but, because of their problematic content — Gnostic texts, amongst which the

<sup>342</sup>. Zuk 2008.

<sup>343</sup>. Harrison *et al.* 2012.

<sup>344</sup>. Doresse 1949.

<sup>345</sup>. Doresse & Mina 1949.

only complete example of the non-canonical Gospel of Thomas — they were not made available to scholars for years.<sup>346</sup> In 1961, Doresse<sup>347</sup> presented a first brief study of the bindings with some sketches. However, from the description of the bindings by Robinson done in the 1970s,<sup>348</sup> it is sadly clear that the bindings had already been dismantled without careful documentation, with some parts already lost and not in their original state, leaving aspects of the original binding structure unclear and not recoverable from the evidence remaining.<sup>349</sup> Even with this in mind, Szirmai's reconstructions, reproduced in Figure 31, do not offer any indication of what is certain and what is conjectural about the binding structure of the Nag Hammadi codices. This is a clear example of the norm within the field of the archaeology of the book: in the literature, to this author's knowledge, there are no examples of visualizations that include the idea of any kind of uncertainty.

#### 5.4.2.1.2. *UNCERTAINTY CLUES IN ARCHAEOLOGICAL VISUALIZATIONS*

Despite the many photorealistic archaeological visualizations that do not offer a way to distinguish between speculation and hard data, the issue of uncertainty in archaeological visualization has been raised by many scholars in the past two decades.<sup>350</sup>

Different approaches have been proposed to tackle the uncertainty problem. For the most part, these try to add some visual clues to photorealistic visualizations, like the use of colour, fog, and transparency.<sup>351</sup> Some studies<sup>352</sup> have opted to use non-photorealistic methods instead, and show how sketch-like renditions coupled with the use of other visual dimensions — e.g. transparency — are fully capable of conveying speculative data as opposed to hard data in archaeological reconstructions. However, more and more the appeal of photorealistic reconstructions

---

<sup>346</sup>. Robinson 1984; Szirmai 1999.

<sup>347</sup>. Doresse 1961.

<sup>348</sup>. Robinson 1972-1977.

<sup>349</sup>. Szirmai 1999.

<sup>350</sup>. Miller & Richards 1995; Ryan 1996; Zuk *et al.* 2005; Bentkowska-Kafel *et al.* 2012; Harrison *et al.* 2012.

<sup>351</sup>. Pang *et al.* 1997; Zuk 2008.

<sup>352</sup>. Strothotte *et al.* 1994; Strothotte *et al.* 1999; Strothotte *et al.* 1999; Freudenberg *et al.* 2001; Strothotte & Schlechtweg 2002; Roussou & Drettakis 2003.



that can be seen as photographs of a possible past, with its communicative power, has won notwithstanding the resulting false certainty.<sup>353</sup>

#### 5.4.2.2. IRREGULARITIES IN VISUAL PROPOSITIONS

Even though the archaeological visualizations mentioned in the previous sections refer to three-dimensional reconstructions — whether photorealistic or not — it is interesting to note how they include visual cues to the figure, and these visual cues can be applied to a single artefact, or an entire group or scene.<sup>354</sup> By doing so, they manage to convey the uncertainty of certain parts of the reconstruction, without altering the perception of the object as a whole.

It is, in fact, possible to add irregularities to a certain figure, without distorting the overall meaning of visual propositions, for even the ‘irregularities depict what they are intended to express’.<sup>355</sup> However, attention should be paid to avoid triggering unwanted Gestalt laws because of the interplay of particular uncertainty encodings — e.g. changing the figure/ground balance — thus shifting attention.<sup>356</sup>

#### 5.4.2.2.1. VISUAL CUES FOR UNCERTAINTY VISUALIZATION

In the literature across different domains, the list of possible visual cues for visualizing uncertainty is limited to a range of seven categories: (i) size, (ii) position, (iii) texture, (iv) shape, (v) colour/saturation, (vi) transparency/fading, (vii) blur.<sup>357</sup> Interestingly, these correspond, for the most part, to the retinal variable outlined by Bertin,<sup>358</sup> with the exception of *orientation*, that is never used to depict uncertainty, and *value* that is not used in isolation, but it is rather used together with

---

<sup>353</sup>. Harrison *et al.* 2012.

<sup>354</sup>. Zuk 2008.

<sup>355</sup>. Wittgenstein 1922/2012T: 4.013.

<sup>356</sup>. Zuk 2008.

<sup>357</sup>. For reviews of different uncertainty visualization strategies see: MacEachren 1992; Goodchild *et al.* 1994; Strothotte *et al.* 1994; Pang *et al.* 1997; Strothotte *et al.* 1999; Strothotte *et al.* 1999; Pang 2001; MacEachren *et al.* 2005; Thomson *et al.* 2005; Wilkinson 2005; Griethe & Schumann 2006; Zuk & Carpendale 2006; Zuk & Carpendale 2007; Zuk 2008; Boukhelifa *et al.* 2012; Brodlie *et al.* 2012.

<sup>358</sup>. Bertin 1983/2011.

colour or in transparency and fading. To Bertin's variables, MacEachren<sup>359</sup> adds *blurring* and the aforementioned *transparency* variable.

Size and position only apply to quantitative data visualization within diagrams,<sup>360</sup> as in iconic texts both the size of an element and its position have to be relative to those of the other elements for their signification.

Texture, defined by Bertin<sup>361</sup> as the number of separable marks within a unit (point, line, area), work by altering the appearance of the unit by making it look as if formed by a series of successive marks, which are read as pertaining to the same semantic unit due to the Gestalt principles of continuity and grouping.<sup>362</sup> Dashing or dotting is an example of texture applied to lines. In bookbinding line drawings, the norm is to use a dotted or dashed line to represent elements or parts of elements, that in reality would be partially or completely hidden and thus not visible. Sometimes, the same convention of dashing lines is used for other reasons, such as to indicate folds (see Figure 32). This means that the texture dimension has already been assigned various values, and it should not be used with yet another meaning.

For material object visualizations, the general shape of an item cannot be changed arbitrarily. However, the shape of the lines making up the drawings can be modified to carry some special meaning, in the same way as texture can change the appearance of a line without altering its overall shape. Sketchy or wiggly lines fall within this category. The research group of Boukhelifa, Wood, and colleagues,<sup>363</sup> inspired by the work on non-photorealistic rendering reported above, have explored the capability of sketchiness to convey visual imprecision that may be associated with uncertainty. Their results show that whilst some users associated sketchiness with unprofessional rendering, it is nonetheless a viable additional choice.

Hue variations, as we have seen in §5.3.3.3, should be avoided if at all possible. For black and white line drawings on a neutral background, the variables of *grey*

---

<sup>359</sup>. MacEachren 1992.

<sup>360</sup>. Wilkinson 2005.

<sup>361</sup>. Bertin 1983/2011.

<sup>362</sup>. Koffka 1935.

<sup>363</sup>. Boukhelifa *et al.* 2012; Wood *et al.* 2012.

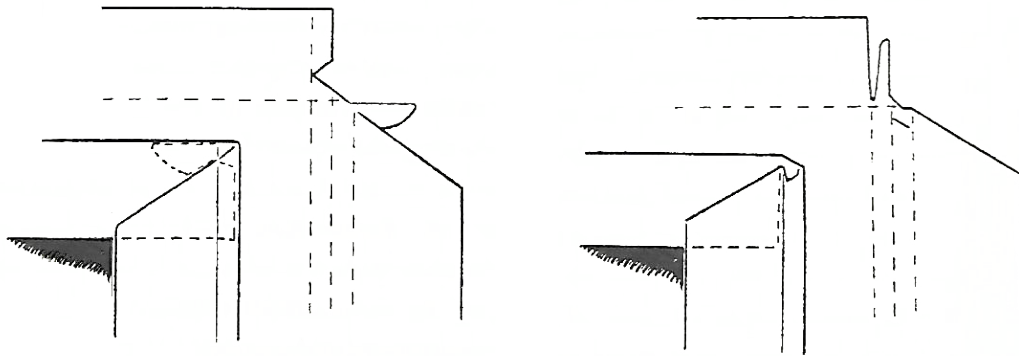

Figure 32. Drawings showing the use of dashed lines to indicate both invisible parts and folds (Clarkson 2005, fig. 7 and 8, p. 9).

*scale saturation*, *transparency*, and *fading* fall within the same category and are not separable. These variations provide redundant encoding as they use more than one variable and channel of vision area 1 (V1)<sup>364</sup> at a time. As a consequence, they are easily perceivable and good candidates for carrying extra information,<sup>365</sup> e.g. darker lines, being visually more prominent, suggest more certainty than lighter lines.<sup>366</sup> The same is valid for *blurring*,<sup>367</sup> which can be defined as the removal of spatial detail from the information.<sup>368</sup> This variable too is redundant and acts on the variables of *grey scale saturation*, *transparency*, and *fading*. But in addition, it also banks on the V1 feature of sharpness/blurriness detection,<sup>369</sup> which makes it an even more redundant and distinguishable variable. *Blurring* has been widely used to indicate uncertainty and ambiguity in the data across fields.<sup>370</sup>

Of the various visual cues that have been used in the literature to express uncertainty, the methods that are applicable to line primitives can be grouped into three main categories: (i) colour-based techniques manipulating the saturation, or brightness dimensions; (ii) geometry-based techniques that modify the appearance of line marks; and, (iii) focus-based techniques that work by modifying

<sup>364</sup>. Ware 2013.

<sup>365</sup>. Zuk & Carpendale 2006.

<sup>366</sup>. Boukhelifa *et al.* 2012.

<sup>367</sup>. Zuk & Carpendale 2006.

<sup>368</sup>. Boukhelifa *et al.* 2012.

<sup>369</sup>. Ware 2013.

<sup>370</sup>. MacEachren 1992; Pang *et al.* 1997; Wilkinson 2005; Wilkinson 2005; Zuk & Carpendale 2006; Zuk 2008; Boukhelifa *et al.* 2012.

contour crispness, and transparency.<sup>371</sup> To summarize, *grey scale saturation* and *transparency/fading*, used on their own or in conjunction with *blurring*, and *sketchiness of lines* appear to be optimum variables for this project. All of these are also applicable selectively on specific single elements: an ideal feature for structured visualizations.

#### 5.4.2.3. IMPRECISION AS UNCERTAINTY

Uncertainty in the data, that in turn should be mapped and rendered as such in the final visualization, falls within the categories of accuracy and completeness of recorded information, and of the precision of measurements.

The sections above have covered the problems that may lead to uncertainty in the data for a structured description of material objects such as bookbinding structures, covering the accuracy and completeness categories.

In regard to measurements, it should be stated again here that their precision is not essential to the prototypification of shape, as measurements do not constitute a *prägnant* feature.<sup>372</sup> Measurement values can, in fact, be changed without psychologically affecting the overall impression for the observer as long as the proportions are left unaltered.<sup>373</sup> Nevertheless, when the measurement of certain elements can be compared from object to object, it is important to be able to highlight uncertainty in regard to the extension of a particular line: the length or scale of an element may, in fact, be critical to understanding certain features of the material object described and visualized.<sup>374</sup>

#### 5.4.2.4. UNCERTAINTY INHERENT IN THE VISUALIZATION PROCESS

Finally, as seen, in the passage from verbal descriptions to visual, some features of the specificity of an object may be lost due to the prototypicality of verbal in-

---

<sup>371</sup>. Boukhelifa *et al.* 2012.

<sup>372</sup>. As seen in §3.4.2.2, a singular, meaningful, special value of a trait or parameter. (Palmer 1999; Sternberg & Mio 2009).

<sup>373</sup>. Goldmeier 1972.

<sup>374</sup>. Campagnolo & Velios 2013.

formation, the generalization inherent in defined signs, and the semantic entry level used in the description. This does not mean that an object cannot be visualized at all, but that in some cases, the prototypified shape would be too generalized to resemble reality closely. If indeed its category was presented in the description at the right level of abstraction, thus highlighting its parts and their arrangement, its essence would be present;<sup>375</sup> however, its overall shape might be overly simplified and symmetrical.

This poses a problem of uncertainty that becomes apparent only in the visualization of the data, and it is an accuracy problem. It might be linked to complex contours of certain elements, e.g. due to highly decorative patterns, or shapes with random and irregular outlines.

In these cases, highly prototypical shapes can be used as place-holders. These can then be highlighted as uncertain for formal integrity.

#### 5.4.3. HUMAN ERROR IN THE DATA

When inaccuracy is objectively determinable, it can be expressed as error.<sup>376</sup> Errors are indicated by the fact that a planned sequence of activities fails to achieve the intended outcome, without intervention of external factors.<sup>377</sup> In electronic databases, the encoding schema at the base of their structure allows for immediate monitoring of data correctness and completeness during input.<sup>378</sup> Missing and inadmissible data is highlighted right away by the computer, prompting the user to add or correct it. Data validation yields to a reduction in errors and acts as quality control. However, not all mistakes can be avoided through careful database design, and those errors that do occur are not easy to identify through automated means.<sup>379</sup>

---

<sup>375</sup>. Tversky & Hemenway 1984.

<sup>376</sup>. MacEachren *et al.* 2005.

<sup>377</sup>. Reason 1990.

<sup>378</sup>. Mocean 2007.

<sup>379</sup>. Campagnolo 2014a.

Data validation is the process of ensuring that a dataset is complete, correct and meaningful. Validation rules check for correctness or meaningfulness of data that are input by the user.<sup>380</sup> Just as in language, a dataset can be considered valid, when it satisfies the validation rules put in place in the system, but this does not necessarily mean that it is also meaningful. In fact, one should not confuse the notion of ‘grammatically correct’ — or ‘valid according to the validation routines’ — with ‘meaningful’.<sup>381</sup>

Consider the following sentences: (i) *colourless sewing passing through four stations*; (ii) *stations through passing four sewing colourless*. Both are nonsensical, but (i) would be recognised as grammatically correct by any English speaker. One can, in fact, distinguish between two senses of meaningfulness or validity. A proposition that is ‘valid in the first sense’ is meaningful in as much as it follows the rules of the language in which it is expressed — e.g. it follows the rules of sentence formation set by English grammar. A proposition that is ‘valid in the second sense’ is meaningful in as much as it makes sense in the context in which it is used.<sup>382</sup> That is to say that a statement can be ‘meaningful in the first sense’ — i.e. it makes grammatically sense — but ‘meaningless in the second sense’ — i.e. in the context in which it has been used. Example (i) above is ‘valid in the first sense’, but not in the second sense, i.e. there does not seem to be a context in which such a sentence would make sense, and it is not meaningful as a bookbinding sewing description.

In the same way, data within a database can be valid — grammatically correct — but nonetheless meaningless. Data that is not ‘valid in the first sense’ can be avoided through validation routines. Ambiguities due to human error that cause ‘invalidity in the second sense’ are, instead, not avoidable through data validation.

In the case of visualizations, data that is grammatically valid — i.e. ‘valid in the first sense’ — but meaningless — i.e. not ‘valid in the second sense’ — would translate into drawings, whose elements are all possible within the state of affairs being described, but represent something that might not be in reality, or does not

---

<sup>380</sup>. Mocean 2007.

<sup>381</sup>. Chomsky 1957.

<sup>382</sup>. Wittgenstein 1969; Stoutland 1998.

reflect what the reality actually is. To check if a visualization is correct or incorrect, one has to check that proposition against reality.<sup>383</sup> Of all the possible configurations of the elements of a material object, one and only one corresponds to reality, and from a proposition it is not always possible to see that it is, in fact, false.<sup>384</sup> A proposition can be understood without knowing if it is true or false as it is understood by virtue of understanding its constituent parts.<sup>385</sup>

Meaninglessness ‘in the first sense’ can be avoided through data validation. Ambiguities due to human error that make propositions not ‘valid in the second sense’ instead are not avoidable through data validation, and are, therefore, not avoidable in visualizations either. Some mistakes, might be immediately recognised as false propositions, because they are meaningless ‘in the first sense’, but in accordance with the rules of reality — as they do not show a configuration that would be possible in real life — and not of the schema, i.e. the elements that compose them are all possible according to the schema, but their coming together in the visualization is meaningless. Other propositions instead, might not be recognized as meaningless until they are indeed checked against reality, as their being meaningless is related to ‘validity in the second sense’, and their being meaningful is then context-dependent and the only way to understand how the object really looked like is to check the proposition against reality. In chapter 7, these cases are discussed with practical examples taken from the dataset.

## Summary

Signs and reality are in relationship with one another. Objects and their arrangement in reality are mirrored in communication as the object determines the sign by imposing the constraints that the sign ought to meet to signify it. Controlled vocabularies and structured descriptions have, in potency, the capacity to describe material objects in such a way that the correspondences to reality, its objects, and

---

<sup>383</sup>. Wittgenstein 1922/2012*T*: 4.05; *T*: 4.06; *T*: 4.1.

<sup>384</sup>. Wittgenstein 1922/2012*T*: 2.223; *T*: 2.224.

<sup>385</sup>. Wittgenstein 1922/2012*T*: 4.024.

its logical form are maintained. At the same time, diagrammatic visualizations are capable of preserving and communicating the form of the reality that they represent. It is thus possible to foresee an intersemiotic translation of propositions from verbal structured descriptions to diagrams, with a one-to-one relationship between the basic elements of each.

Visual signs are specific to a certain domain. It is, however, possible to draw general considerations on the nature of visual signs and to establish general conventions for the production of a successful visual communication system. In particular, it is important to fix the meaning of each sign and of the diagram in its totality, and to avoid altering such meaning with graphical and perception/psychological artefacts, such as the inclusion of information gaps within the visualization plane, or grouping meaningful marks that should be kept visually separate for optimum legibility.

Visualizations within scholarly research projects should convey uncertainty where needed. Depicting uncertainty has been the object of study of many scholars, however, its application to diagrams whose shapes are dictated by those of the objects being represented, as in the case of material objects, poses particular issues and constraints. Various variables have been used to depict uncertainty, of these, blurring, grey scale variation, transparency, fading, and sketchy lines seem to be better suited to be applied to material object visualizations.

Noteworthy is the fact that, in the literature, uncertainty has not been considered yet for visualizations pertaining to the field of the archaeology of the book. This project has endeavoured to amend this and brings forward a methodology to include uncertainty in a consistent manner in the visualization of historical book-binding structures. This constitutes an important contribution of this work to the field of the archaeology of the book.

Human errors in the data can be limited with the implementation of data validation techniques. These, however, will not eliminate the possibility of erroneous data being input. False visualizations caused by these errors are readable, and sometimes even identifiable as erroneous, but their validity has to be checked against reality.



The following chapters will show the visual language developed for this project and the practical application of the considerations covered so far.

## Chapter 6. Transformation framework

*The concept, element, can be understood in two different ways: as an external, and, as an inner concept. Externally, each individual graphic or pictorial form is an element. Inwardly, it is not this form itself but, rather, the tension within it, which constitutes the element.*

Wassily Kandisky, *Point and line to plane*, 1947, p. 33.

This chapter introduces the technologies that have been used in this project, the dataset, and the schema developed by *Ligatus* in more detail. The next chapter gives a complete example of a transformation and introduces other bookbinding structure transformations. A complete account of each transformation can be found in Appendix B.

## 6.1. The technology and the description schema

### 6.1.1. EXTENSIBLE MARKUP LANGUAGE

This project makes extensive use of the eXtensible Markup Language (XML)<sup>386</sup> and associated technologies.

XML was developed in 1996 by an XML Working Group formed under the auspices of the World Wide Web Consortium (W3C)<sup>387</sup> to meet the challenges of large-scale electronic publishing. With time, XML has also been playing an increasingly important role in the exchange of data on the Web and elsewhere.<sup>388</sup> XML 1.0 (fifth edition) is a W3C Recommendation and is the most recent version of the full specification.<sup>389</sup> XML technologies are widely used to structure, store, exchange, and process data in a system-independent way. XML, as a markup language, is designed to process and define information in the form of text. HyperText Markup Language (HTML) is an example of widely known and used markup language for web pages. XML is a metalanguage, a language used to describe other markup languages (including XHTML, eXtensible HyperText Markup Language, a version of HTML). In essence, XML is a grammar that specifies how to distinguish markup from other information, and which markup is allowed and required. XML does not specify the meaning of the markup.

In XML, markup instructions are intermixed with data in the same document. Markup instructions, referred to as *elements*, are kept distinct by enclosing them in angular brackets like this <element>.

*Elements* are the basic unit of XML documents. Each type of element is identified by a name — i.e. the word within the angular brackets — but XML does not prescribe the way to express the semantic meaning linked to a particular type of element. All XML does is express an element's relationship to other elements. Given an element called <foo>, all one can say about it, thanks to the XML

---

<sup>386</sup>. Bray *et al.* 2008.

<sup>387</sup>. <http://www.w3.org/> (accessed April 2015).

<sup>388</sup>. Bray *et al.* 2008; W3C 2015.

<sup>389</sup>. Bray *et al.* 2008.

grammar ruling an XML document, is that it may (or may not) occur within elements of the type called <bar>, and that it may (or may not) contain elements called <baz>. XML documents are in fact innately hierarchical and form a tree structure that starts at the *root* and branches to the *leaves*.

The XML grammars describing and prescribing these kinds of relationships and the elements types (with their names) are referred to as *schemas*. An XML document is created according to a specific schema and validated against it. Every schema has to follow the general rules set by the XML specification by the World Wide Web Consortium that created it.

XML languages are being used to structure various other types of information besides text, e.g. vector graphics, procedural information, and so forth.

#### 6.1.2. EXTENSIBLE STYLESHEET LANGUAGE TRANSFORMATIONS

XML documents have no set function. Once a document is structured according to a specific schema, the information is semantically highlighted and therefore searchable, but nothing else happens. Once encoded, however, it can be transported, exchanged, and transformed into other forms.

EXtensible Stylesheet Language Transformations (XSLT),<sup>390</sup> part of the eXtensible Stylesheet Language (XSL), a style sheet language for XML documents, is an XML technology developed to transform XML documents — or parts of them — into other XML documents or other formats.

XSLT is a standard of the World Wide Web Consortium. Although referred to as *stylesheet*, XSLT is essentially a fully-developed programming language that is well-suited to extrapolate information from XML documents and transform it into whichever format is desired, be that a web page, a PDF file, or a diagram. It is therefore an ideal language for intersemiotic translations of information encoded within XML documents.

---

<sup>390</sup>. Clark 1999.

### 6.1.3. SCALABLE VECTOR GRAPHICS

This project aims to extrapolate information from XML documents describing bookbinding structures and transform it into diagrammatic visualizations. The project's dataset was already in XML and one can use an XML-based language to transform it; it therefore makes sense to use an XML technology to visualize the output.

Scalable Vector Graphics (SVG)<sup>391</sup> is a language for describing two-dimensional vector graphics in XML. Originating from the requirements for scalable graphics for the web by Chris Lilley,<sup>392</sup> the SVG specification is an open standard developed by the World Wide Web Consortium (W3C) since 1999. SVG 1.1 (second edition) is a W3C Recommendation and is the most recent version of the full specification.<sup>393</sup>

SVG uses elements to describe in text form how its vectorial shapes should be rendered and visualized. It is *scalable* because it defines the shape of each graphic element but in a scale independent way, i.e. each element can be scaled up or down without affecting the quality of the image.<sup>394</sup>

SVG is recommended by the World Wide Web Consortium and, as such, integrates with other W3C standards, e.g. XSL. Being XML-based, SVG is a good choice for the visual representations automatically generated for this project.

### 6.1.4. THE DESCRIPTION SCHEMA AND THE DATASET

In analysing the different kinds of bookbinding structure descriptions in the literature in chapter 4, the schema developed by *Ligatus* was briefly introduced. This is an example of a structured description that makes use of a purposely developed controlled vocabulary. As such, it is capable of conveying the minimum information needed for a transformation of the information into visual representations. Through its hierarchical structure and the use of a strict controlled

---

<sup>391</sup>. Dahlström *et al.* 2011.

<sup>392</sup>. Lilley 1996.

<sup>393</sup>. Dahlström *et al.* 2011.

<sup>394</sup>. Terras 2008.

vocabulary it can portray information on the material components and form of the object. The schema can also convey the prototypical shapes of the components through the prototypical nature of the vocabulary used, if the terms are set at the most useful level of abstraction. The schema also embodies the expression of the description, and this provides a direct link with the logical form of the object being described.

The schema is the basis of the project's dataset. The following sections offer a detailed introduction to its history and structure, and look at the data generated through it.

#### 6.1.4.1. THE *LIGATUS* SCHEMA FOR THE DESCRIPTION OF BOOKBINDING STRUCTURES

In the introduction of *The Archaeology of Medieval Bookbinding* Szirmai<sup>395</sup> points out that 'terminological clarity is a prerequisite for precise recording of observation in binding structures [and] the lack of an established and uniform English terminology [prevents] from achieving the [desired] precision.' *Ligatus* has tried to tackle the terminology problem, whilst also advancing a methodology for the description of bookbinding structures. The terminology and description methodology were first applied during the condition survey of the library of Saint Catherine Monastery on Mount Sinai, carried out by team of conservators<sup>396</sup> from 2001 to 2007.

##### 6.1.4.1.1. THE MANUSCRIPT COLLECTION SURVEY

The terminology and methodology proposed by *Ligatus* was then developed and applied in the condition survey of the library of Saint Catherine Monastery on Mount Sinai. The survey project was run by the Saint Catherine Foundation<sup>397</sup> and *Ligatus*. The library's holdings are codicologically very important, especially because of the variety of early bookbinding structures that have survived. The main scope of the project was the preservation of the library. However, to establish

---

<sup>395</sup>. Szirmai 1999, p. xii.

<sup>396</sup>. A list of the visiting conservators can be found at <http://www.ligatus.org.uk/people> (accessed April 2015). This author was not part of the project for the duration of the survey.

<sup>397</sup>. <http://www.saintcatherinefoundation.org/en/> (accessed March 2014).

a conservation plan for the library, a detailed survey of all the volumes was proposed to assess the whole of the collection and produce a comprehensive record of the material.<sup>398</sup>

The survey of the manuscript collection was run from 2001 to 2006, and it included a record of the condition and the structure of the bindings in as much detail as possible given the time constraints. Each volume was allocated about one hour for its description. The work was done in teams of two people to avoid as many possible errors in the data recording.<sup>399</sup>

The data collected was noted on paper forms (see Figure 33), kept aside as a physical backup, and then automatically uploaded into a database developed for the project. About 3,300 books have been examined. At first the data was organized into a relational database. But given the hierarchical nature of the recorded data, the relational model was abandoned in favour of XML records.<sup>400</sup>

#### 6.1.4.1.2. *THE PRINTED BOOK COLLECTION SURVEY*

The way in which information was collected during the survey followed the well-established method of following the way in which the book was put together originally,<sup>401</sup> starting with general observations, then progressing to the finer detail: this is a highly hierarchical methodology that is best expressed through another hierarchical descriptive methodology. A second development of the survey methodology made use of XML's inherent hierarchical nature.<sup>402</sup>

*Ligatus* developed an XML schema to describe bookbinding structures. A new description schema was developed as no existing solution could describe binding structures in such detail. This schema, based on the experience accrued during the first phase of the survey, was devised to encompass the kind of structures likely to be found in the collections to be surveyed, but it was not comprehensive.

---

<sup>398</sup>. Pickwoad 2004.

<sup>399</sup>. Pickwoad 2004.

<sup>400</sup>. Pickwoad 2004; Velios & Pickwoad 2004; Velios & Pickwoad 2005a; Velios & Pickwoad 2005b; Velios & Pickwoad 2008.

<sup>401</sup>. Sharpe 2000.

<sup>402</sup>. Velios & Pickwoad 2005a; Velios 2008; Velios & Pickwoad 2008; Velios & Pickwoad 2009.

MS GR 592

## 8. PRIMARY COVERING

**1. PRIMARY**  Yes  No  NK

<b>TYPE</b> <input checked="" type="checkbox"/> Full <input type="checkbox"/> Quarter <input type="checkbox"/> None <input type="checkbox"/> Missing <input type="checkbox"/> NK <input type="checkbox"/> See below, 3 <input checked="" type="checkbox"/> Hairside out <input type="checkbox"/> Fleshside out COLOUR <u>DK BROWN</u>	<b>MATERIAL</b> <input checked="" type="checkbox"/> Tanned skin <input type="checkbox"/> Tawed skin <input type="checkbox"/> Parchment <input type="checkbox"/> Cartonnage <input type="checkbox"/> Paper <input type="checkbox"/> Textile <input type="checkbox"/> NK <input type="checkbox"/> Other	<b>SOURCE</b> <input type="checkbox"/> Goat <input type="checkbox"/> Sheep <input type="checkbox"/> Hairsheep <input type="checkbox"/> Calf <input checked="" type="checkbox"/> NK <input type="checkbox"/> Other	<b>STATUS</b> <input checked="" type="checkbox"/> First use <input type="checkbox"/> Re-used <input type="checkbox"/> MS <input type="checkbox"/> Printed <input type="checkbox"/> Book cover <input type="checkbox"/> Pieced <input type="checkbox"/> NK <input type="checkbox"/> Other	<b>CORNERS</b> <input type="checkbox"/> Lapped Fe over <input type="checkbox"/> Lapped H & T over <input type="checkbox"/> Lapped mixed <input type="checkbox"/> Tongued mitre <input checked="" type="checkbox"/> Butt mitre <input type="checkbox"/> Open mitre <input type="checkbox"/> NK <input type="checkbox"/> Other
---	---	---	--	--

EXISTING REPAIRS  Overback  Patched  Other  Cap core

**2. TOOLING**  None  NK  Fillets

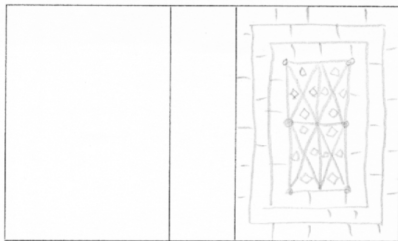
<input checked="" type="checkbox"/> Yes <input checked="" type="checkbox"/> Blind tooling <input type="checkbox"/> Gold tooling <input type="checkbox"/> NK <input type="checkbox"/> Other	<input type="checkbox"/> Rolls <input checked="" type="checkbox"/> Small tools <input type="checkbox"/> Centre piece <input type="checkbox"/> Corner piece <input type="checkbox"/> Other	
--	---	--

IMPRESSION QUALITY  High  Medium  Low

No. of rolls  No. of small tools 4

**3. CONDITION (PRIMARY)** [HATCH ALL THE MISSING AREAS OF COVERING MATERIAL]

Right      Spine      Left

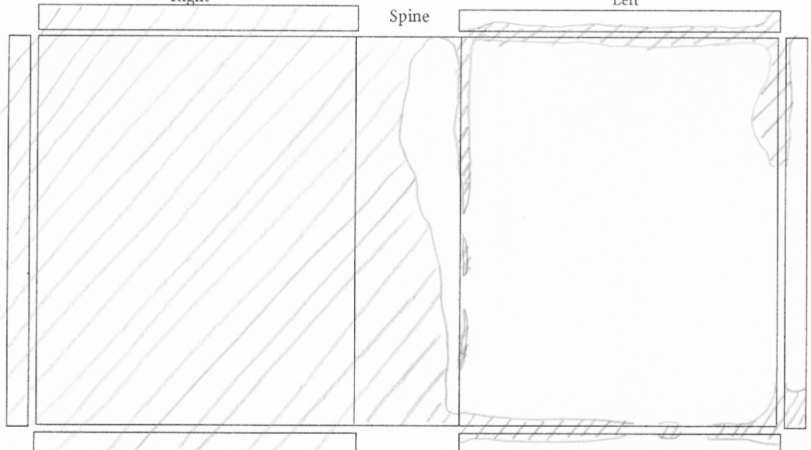

**4. CONDITION (PRIMARY)**

Extent	Severity	Extent	Severity	Extent	Severity
<input type="checkbox"/> 60	<input checked="" type="checkbox"/> Missing	<input type="checkbox"/>	<input type="checkbox"/>	<input type="checkbox"/>	<input type="checkbox"/> Deposits
<input type="checkbox"/> 10	<input checked="" type="checkbox"/> Torn	<input type="checkbox"/>	<input type="checkbox"/>	<input type="checkbox"/>	<input type="checkbox"/> Laceration
<input type="checkbox"/> 60	<input checked="" type="checkbox"/> Abraded	<input type="checkbox"/> 100	<input type="checkbox"/> 20	<input checked="" type="checkbox"/> Embrittled	<input type="checkbox"/> Encrusted
<input type="checkbox"/>	<input type="checkbox"/> Rodent	<input type="checkbox"/>	<input type="checkbox"/>	<input type="checkbox"/>	<input type="checkbox"/> Other
<input type="checkbox"/>	<input type="checkbox"/> Insect	<input type="checkbox"/>	<input type="checkbox"/>	<input type="checkbox"/>	<input type="checkbox"/>
<input type="checkbox"/>	<input type="checkbox"/> Water	<input type="checkbox"/>	<input type="checkbox"/>	<input type="checkbox"/>	<input type="checkbox"/>

Detached, spine  
 Detached, boards  
 Lifted turn-ins  
 Secured by metal fittings only  
 Adhesive tape  
 Other

**5. SECONDARY COVER**  Yes  No  NK

Figure 33. Typical page of the paper form used in the survey of the manuscripts at the Library of St. Catherine's Monastery on Mount Sinai (Velios & Pickwoad 2004, p. 658).



In 2007, teams of conservators visited St. Catherine's Monastery to survey the library's printed book collection. This time, the paper forms were substituted with electronic forms to be filled in directly on a computer screen or tablet. The electronic form utilized the newly-developed XML schema. Unlike the former paper forms, the XML structured descriptions of bindings allowed for immediate data validation during the survey, resulting in fewer errors compared to the paper-based survey of the manuscripts. This way, 814 bookbindings from the printed book collection were described, and the data was stored in XML files generated from the electronic forms.<sup>403</sup>

#### 6.1.4.1.3. *FREE-HAND DRAWINGS*

For both phases of the survey, drawing was considered an important part of the process, as drawing demands observational accuracy, helping to focus on the important details of the item being examined. Information was recorded in outline and diagrammatic drawings which were fast to execute, accurate, and language independent. The drawings, never intended to be realistic, but rather schematic informative documentation, functioned also as a kind of supplementary detailed record of some of the structures, adding visual information to the photographs that were taken for each book.<sup>404</sup>

Drawings were integrated within the paper-forms for the manuscript survey as seen on Figure 33. Whereas, a specially developed new paper form for drawings was devised for the printed book survey: an A3 landscape form with various sections covering the required or possible drawings (see Figure 34). Paper forms were preferred to direct digital input, as people prefer drawing on paper rather than a computer screen.<sup>405</sup>

---

<sup>403</sup>. Velios & Pickwoad 2005a; Velios 2008; Velios & Pickwoad 2008; Velios & Pickwoad 2009.

<sup>404</sup>. Pickwoad 2004; Velios & Pickwoad 2004; Velios & Pickwoad 2005a; Velios & Pickwoad 2005b; Velios & Pickwoad 2008.

<sup>405</sup>. Velios & Pickwoad 2005a.

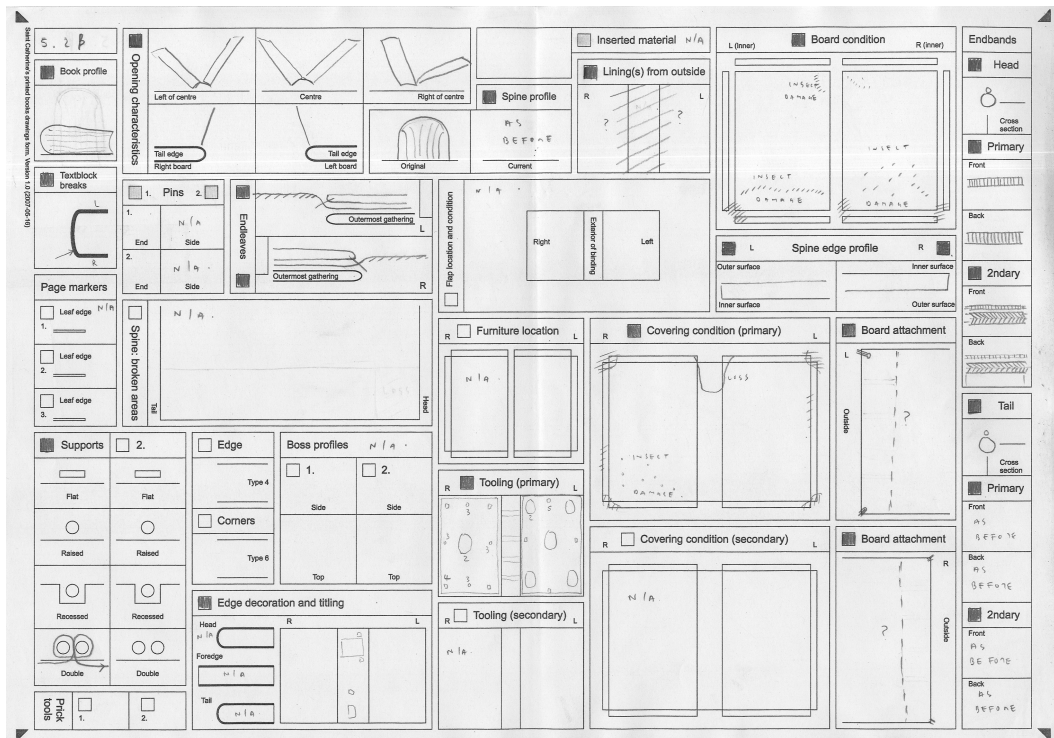

Figure 34. Example of the drawing paper form used during the survey of the printed books at the Library of St. Catherine's Monastery on Mount Sinai developed by *Ligatus*.

#### 6.1.4.2. THE PROJECT DATASET

The transformation algorithms for this project have been based on the kind and amount of data prescribed by the XML schema developed by *Ligatus* for the printed book survey. The 814 XML records collected during the survey represent the validation dataset for the algorithms. These records were used to test and validate that the transformation algorithms could meet acceptable levels of accuracy and performance. Effective data validation is typically difficult to create from scratch; thus transformations for structures theoretically covered by the schema, but for which no examples were found in the dataset, would be problematic to test or develop properly. The printed book collection, however, offered a wide range of binding styles to account for most structures. Simple structures, such as board markers, page markers, and tacketed structures, not found in the dataset were developed nonetheless for reasons of completeness.

## 6.2. The transformations

It is now time to examine which of the structures and structural elements accounted for within the *Ligatus* schema are described in sufficient detail for the information to be automatically transformed into meaningful diagrams.

Figure 35, shows a graphic representation of the hierarchical structure of the *Ligatus* XML schema down to the first level of branching. The root element is obviously the ‘book’ element. Then the elements can be grouped as follows: a first group gathers general information on the item, like bibliographical information, overall dimensions, and opening characteristics. A second group focuses on material that can be added to the volume, like inserted material, and markers. The last group instead, starting from the textblock, the covering and furniture, analyses the formation of the binding component by component. The analysis of the text leaves does not cover gathering formation and collation.

The schema describes the material components, and, to an extent, the form of: markers (page markers, board markers, and bookmarks), endleaves, sewing, boards, spine profile and joints, spine lining, endbands, covering, and furniture. All of these structures are potentially described in sufficient detail to allow for the information to be algorithmically analysed and transformed into diagrammatic representations.

Chapter 7 will present the information contained in the schema component by component. The following sections in this chapter introduce a few general conventions and considerations to help the reader better understand the data presented and the diagrams automatically generated for this project.

### 6.2.1. KNOWLEDGE GRAPH SCHEMAS

Each transformation will be accompanied by a graph showing the complete set of information made available by the schema to describe a binding structure, and the complete set of elements that can be drawn to represent that structure. In turn, these graphs also show what information is available to the viewer for the

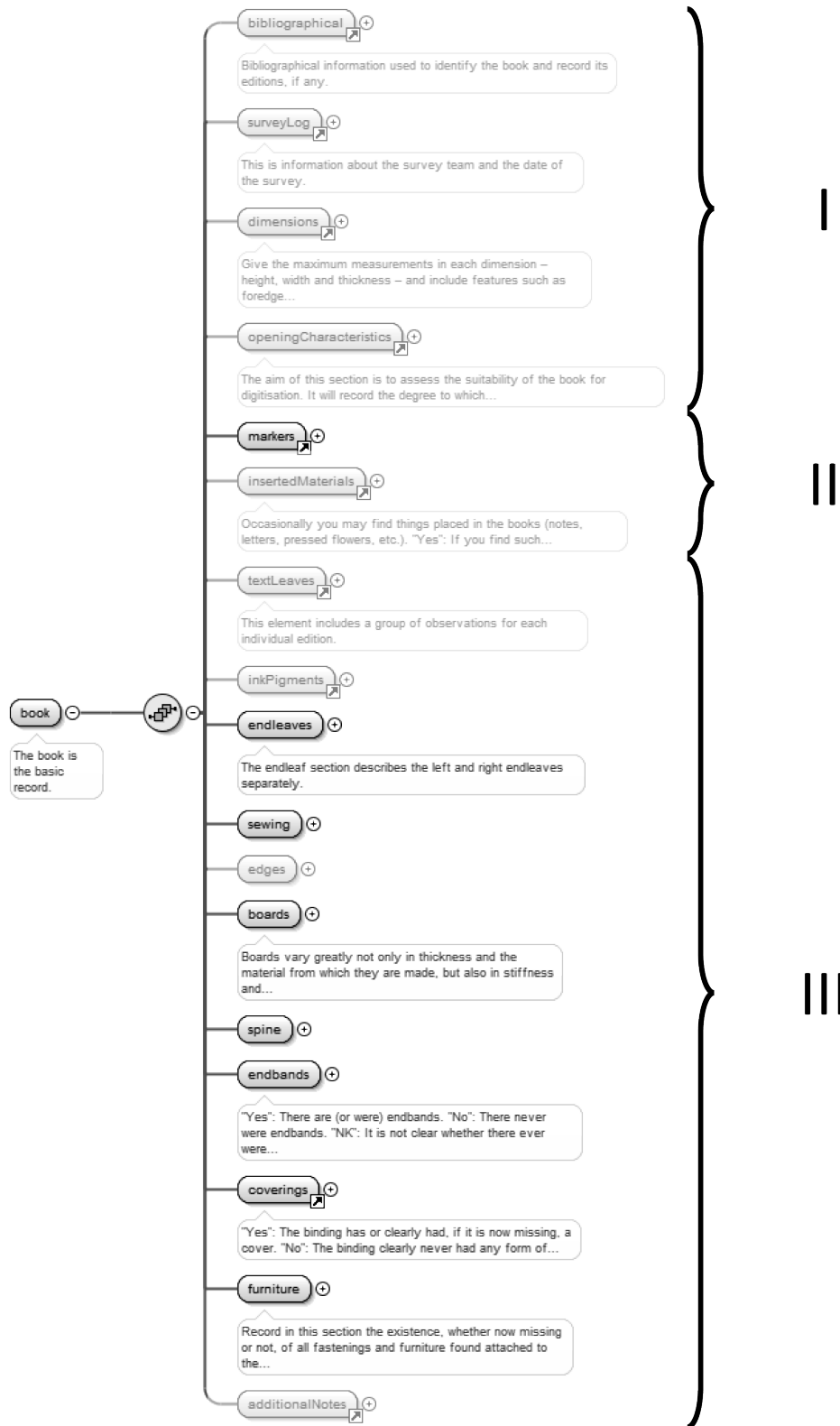

Figure 35. Visualization of the *Ligatus* schema: the root and the first level branches. These can be subdivided into three groups: group I contains the general information on the book; group II contains the material that can be added to the volume; and group III covers the components of the binding.

interpretation of the generated bookbinding structure diagrams. The diagrams are presented as a way to visualize the information behind each transformation. Graph schemas have been devised by this author as a means to show all the information needed for a description/transformation in a single page (or a series of related pages for very complex structures); they visualize both the schema behind each description and the path followed by each algorithmic transformation to generate the diagrams for this project. They can be complicated to follow, but they can also show in one glance the complexity of a transformation, as opposed to having to trail through the XML schema and the XSLT transformation code.

These kind of graphs resemble Findler's<sup>406</sup> associative networks, and Pinker's<sup>407</sup> visual description *graph schemas*.<sup>408</sup> These graphs schemas are helpful for representing the knowledge domain for each transformation. The graphs are formed of nodes and links between nodes. Nodes represent variables identified as concepts, and links represent relations between concepts. They serve also as a way to describe how a reader of a diagram comprehends the bookbinding diagrams. Pinker,<sup>409</sup> in fact, considers them as memory representations embodying knowledge in some domain, each containing slots or parameters for the information. Each graph can both specify what information must be true for the representation of some object of a given class, and what information varies from one exemplar of a class to another.

#### 6.2.1.1. GRAPHIC CONVENTIONS FOR KNOWLEDGE GRAPH SCHEMAS

The graphs show a complete visual description for each bookbinding structure diagram. Nodes are represented by small circles, with textual notations as predicates, and links by arrows linking two entities. Each node that could take different values is represented by a small triangle branching into a series of entities, showing the possible choices, and what information varies from record to record. Parametrized predicates — i.e., here, elements that are defined by precise parameters,

---

<sup>406</sup>. Findler 1979.

<sup>407</sup>. Pinker 1990.

<sup>408</sup>. Pinker 1990, p. 94.

<sup>409</sup>. Pinker 1990.

which, in these instances, is taken to mean numbers and measurements — are indicated by small squares linked to the entity that they define. As in Pinker,<sup>410</sup> a star (\*) inside a node indicates that the node could be repeated more than once. A question mark (?) inside a node indicates that the node can be repeated zero or more times. A dagger symbol (†) indicates nodes whose visual representation is not possible with the present level of information available in the schema. The typical choice values of *not checked* (NC), *not known* (NK), and *other* are indicated, as shorthand notation, by three small blurred filled circles placed under the relevant choice triangle; these are blurred to indicate that the information they provide is uncertain. Similarly, three blurred daggers are placed under a triangle where the lack of sufficient information or the level of uncertainty renders impossible any meaningful and not misleading visual representation. A dashed and dotted line under a triangle, with a circle inscribed in it, is a further shorthand notation for the customary series of choices: *yes*, *no*, *NC*, *NK*, *other*. The circle inscribed in the triangle indicates that something is to be drawn.

In the interest of brevity, and if at all possible without rendering the graph too complex, the same set of nodes is not repeated more than once. Looking at the graphs it becomes clear that the linking lines initiate a logical path of relations along which some information is gathered at each node. Finely dashed lines indicate that some options are only available for a certain path along the schema. These at first identify the beginning of the alternative path, followed by a series of nodes in common to all paths indicated by the usual simple lines up to the point at which the paths divert; what follows is only relevant to the path/s indicated by the first dashed line/s.

There are cases of alternative visualizations. These are generated by the same set of nodes, but arranged spatially in a different fashion. These alternative visualizations are the result of the same algorithm, but the final layout is slightly different — e.g. diagrams for left and right endleaves are mirrored, but still composed of the same kinds of elements. For these, one visualization is fully developed, whilst the others are indicated with a dashed line that fades: from that point onward the

---

<sup>410</sup>. Pinker 1990.

path to be followed would be the same as the fully developed visualization, but the final diagram would have a different spatial layout. Similarly, some structures are particularly complex; for these a set of correlated graph schemas are presented. The groups are identifiable by the arrow at the end of the alternative visualization dashed line pointing to the alternative graph schema (see Figure 36).

#### 6.2.1.2. READING THE VISUAL DESCRIPTION GRAPHS

Each circle in the graphs represents an entity of the visual description. In practical terms, this is taken to mean that for each node something is graphically drawn in the bookbinding diagrams, either as a simple shape, or as a complex series of lines whose final appearance will depend on the exact series of nodes that accompany it. For this reason, the very first element in each graph is a node, indicating the diagram as a whole, of which all the other elements are essentially parts that contribute to its appearance.

Images, as explored in chapter 3, are to be seen and read as *iconic texts*. In practice, visual description graph schemas parse these texts and clearly distinguish the units that compose them. Each unit is understood in relation to the others for the whole meaning to be inferred. Each node can therefore be understood as a graphic notation corresponding to a visual sememe.

Interestingly, as predicted by Saint-Martin,<sup>411</sup> these sememes are *continuous* and *spatialized topological entities*. They are in fact only rarely defined by clear boundaries, and their meaning in effect depends on their spatial arrangement and spatial relations with other sememes. Their spatial location becomes essential to their meaning.<sup>412</sup>

Sememes also vary greatly in size, according to the amount and level of information sought. The largest entity being the whole diagram, a sememe comprising the whole iconic text, which can be read by a reader presented with the diagram in Figure 41 for example as: 'This is the diagram of an endleaf structure.' More information is gathered by delving deeply into the diagram with sememes becoming

---

<sup>411</sup>. Saint-Martin 1990.

<sup>412</sup>. Kubovy 1981; Pinker 1990; Van Valkenburg & Kubovy 2003.

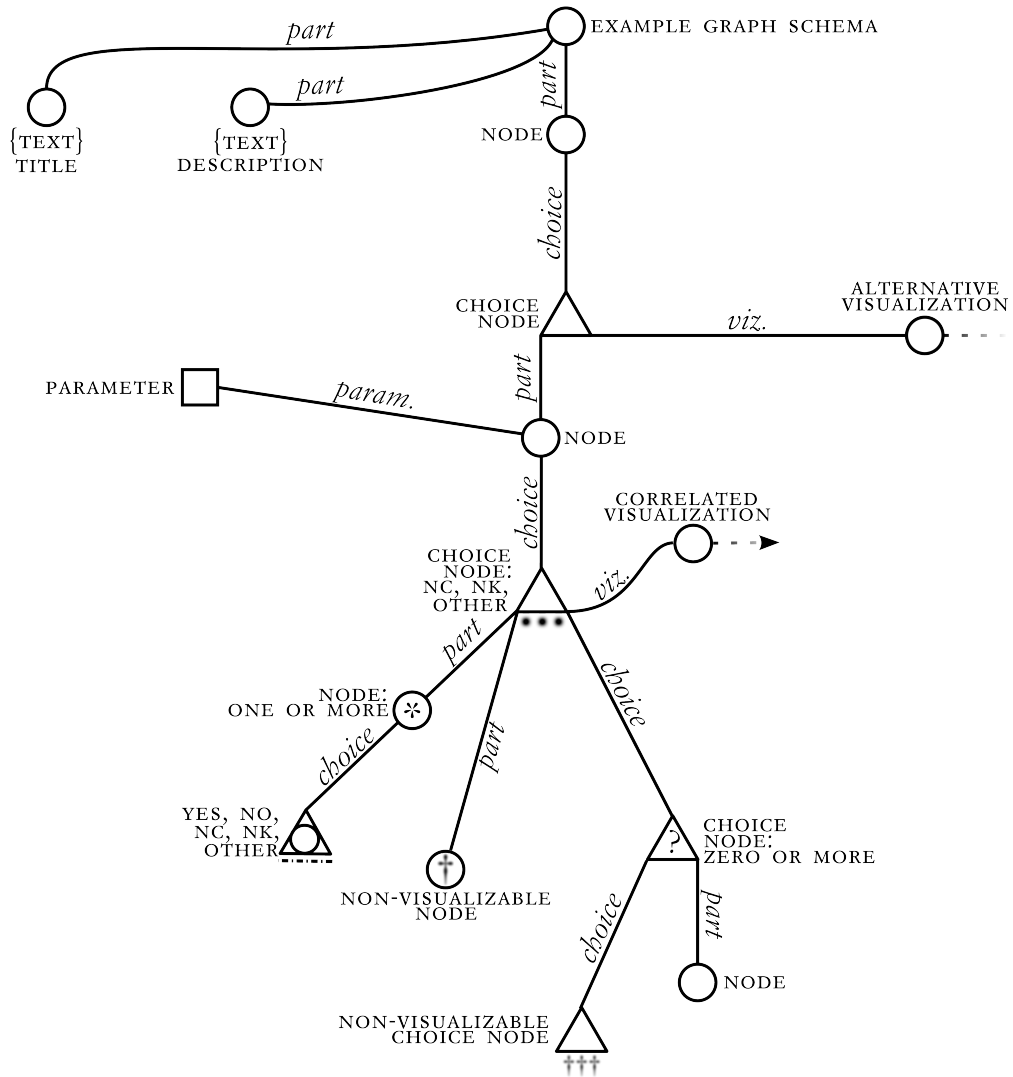

Figure 36. Example graph schema showing the graphical conventions.

smaller and more numerous the more information is read and inferred from the diagram.

### 6.2.2. NUMBER OF POSSIBLE VISUALIZATIONS

Looking at the visual description graph schemas, it is clear that the number of possible nodes is limited. One could argue that, at least for the simplest structures, it would be possible to exhaust all the possibilities and resort to drawing all of these without any transformation. Maybe for such cases going through the effort



of writing an algorithm to generate these diagrams is redundant. But, this is not the case, it can be argued, for at least one good reason: even for a limited number of options, the number of possible visualizations quickly escalates to large numbers. Let us consider two examples: board markers, and endleaf structures.

#### 6.2.2.I. BOARD MARKER VISUALIZATIONS

At first, one of the simplest components in the schema will be considered: board markers, i.e. lengths of animal skin adhered to the inside of a board, projecting from the edge. There are two views for each diagram: cross-sections and views from above; they differ slightly in the information they can provide in regards to the attachment method: for this they will be considered separately. There are two sets of visualizations: (i) location and (ii) position. There are two possible options for location (fore-edge left, fore-edge right), and another two for position (over or under turnin). Finally, (iii) there are two different methods of attachment (glued, nailed), but only the cross-section view can show them both. Having considered all this one can calculate the number of permutations<sup>413</sup> for each view:

(i)

$$\begin{aligned}
 & \text{(Cross-section view + Front view)} = \\
 & = \left[ \frac{n!}{(n-r)!} + \frac{n!}{(n-r)!} \right] = \\
 & = \left[ \frac{6!}{(6-3)!} + \frac{5!}{(5-3)!} \right] = \\
 & = 120 + 60 = 180
 \end{aligned}$$

In principle, it would be possible to hand-draw all 180 different diagrams; it would take some time, but it is feasible. However, should any new characteristic of board markers need to be highlighted, they would all need to be redrawn once more.

By considering more complex structures, it can be seen how the number of permutations quickly escalates to unmanageable numbers.

---

<sup>413</sup>. In mathematics, a permutation can informally be defined as each of several possible ways in which a set or number of things can be ordered or arranged, where the order is important. (Weisstein [s.d.]).

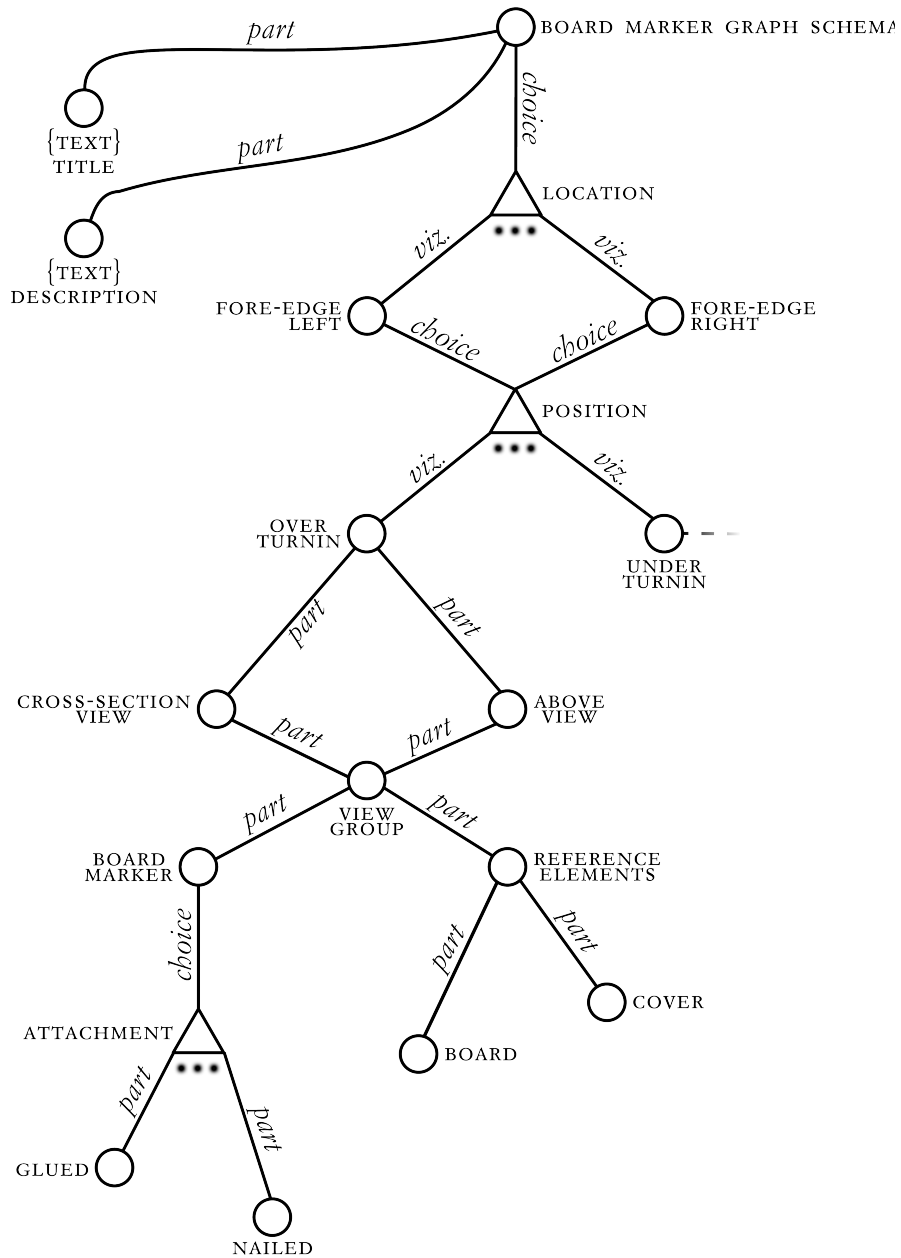

Figure 37. Board-marker graph schema (see §6.2.1).

#### 6.2.2.2. ENDLEAF STRUCTURE VISUALIZATIONS

*Endleaves* are defined as the leaves of a variety of sheet materials found at the front and back of a bookblock. There are two main types: *separate* and *integral* endleaves. The former are added by the binder before the book is sewn and can be described as being composed of units and components; the latter are blank

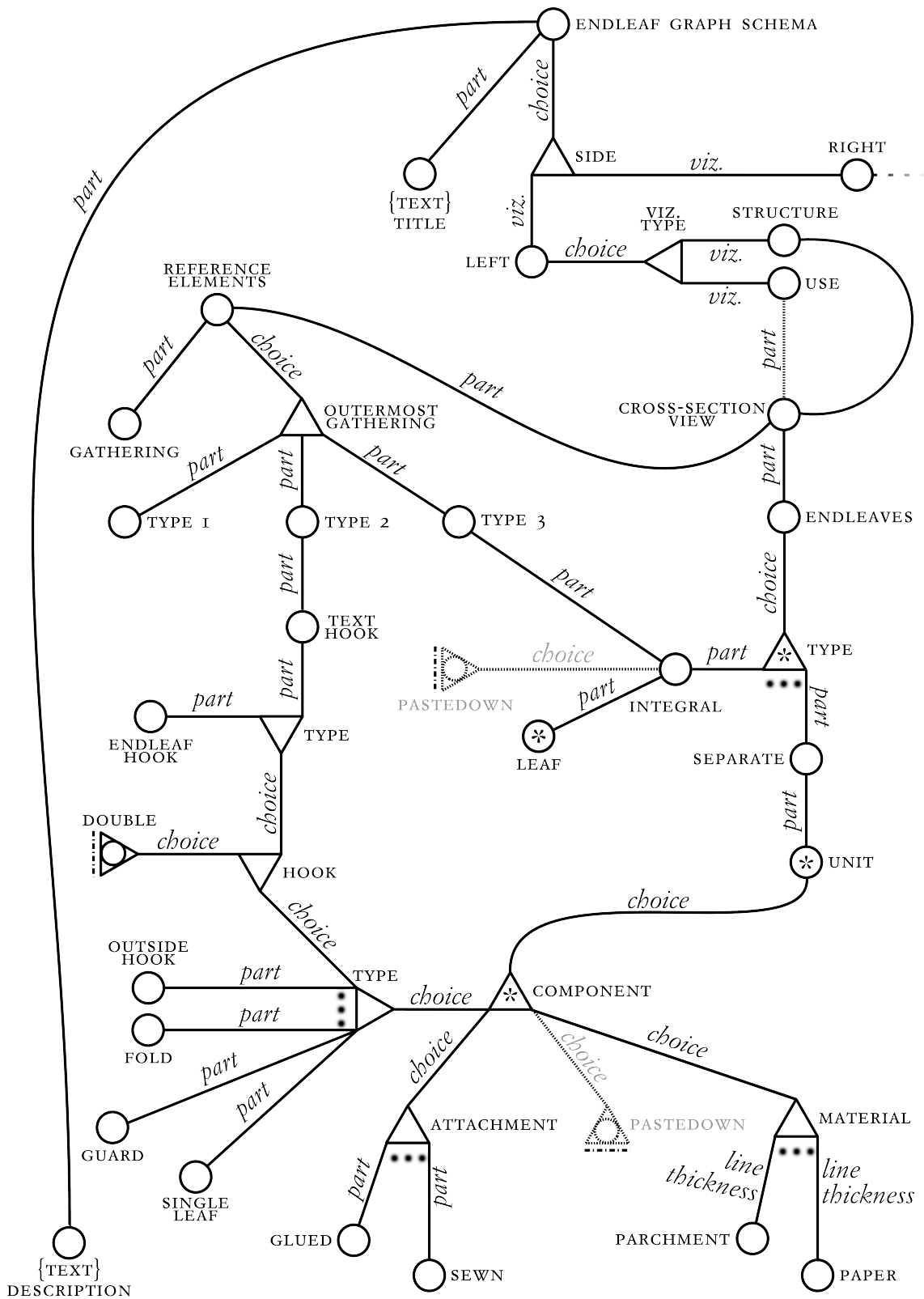

Figure 38. Endleaf graph schema (see §6.2.1).

leaves at the front and/or the back of the textblock, which are used as endleaves. Separate endleaves and integral endleaves can be combined.

Assuming 1 integral endleaf, 1 unit, and 1 component for separate endleaves, one can calculate the number of possible permutations taking into consideration: different visualizations for (i) left and right endleaves, and (ii) for *structure* and *use*; (iii) three graphical options for the outermost gathering; (iv) the two basic types of endleaves, integral and separate. For integral endleaves there are the options of (v) the number of leaves, and (vi) the choice of pastedowns (for *use* visualizations). Separate endleaves are described in (vii) units and (viii) components, both of which can vary in number. For each component there are (ix) the choice of pastedowns (for *use* visualizations), (x) the material, and the visualizations distinguish between paper and parchment by modifying the line thickness, (xi) the modality of attachment (glued, sewn, NC, NK, other), and (xii) the type. Hook types can be (xiii) doubled, and (xiv) can be further divided into endleaf hooks and text hooks. As in most cases, when the information is marked as *not checked* (NC), *not known* (NK), and *other*, the resulting visualization is dealt with according to the standard uncertainty visualization principles, but these are not generally differentiated amongst themselves. Having considered all this one can calculate the number of permutations for each view:

$$\begin{aligned}
 \text{(ii)} \quad & \frac{n!}{(n-r)!} \times \# \text{ basic units} = \\
 & = \frac{27!}{(27-9)!} \times \# \text{ basic units} = \\
 & = 1.700755056 \times 10^{12} \times \# \text{ basic units}
 \end{aligned}$$

1,700,755,056,000 of possible different output diagrams is too large a number for hand-drawing to be a feasible option. An automated visualization instead can generate any of such possible diagrams when and if needed, based on one and only one transformation algorithm.

### 6.2.3. VISUALIZATIONS

Each visualization takes a title with information on the shelfmark of the volume being described and the specific visualization, e.g. ‘left endleaves (*use*)’. A verbal summary description is also provided giving details on the types of components found in the structure. These textual elements act as verbal labels. As seen in chapter 3, there are benefits in combining visual and verbal information. The labels can fix the otherwise ambiguous meaning of visual stimuli allowing for *beta reading modality*.<sup>414</sup> Furthermore, they aid subsequent correct interpretations and recall of the information.

Diagrams make general use of a set of conventional shapes. These shapes have been selected and devised in such a way that what they represent should be immediately clear to a viewer familiar with bookbinding structures and diagrams. The choice of shapes is meant to be consistent and prototypical enough to be representative of any real-life shape, but they often also follow conventions found in the literature. Conventions are both followed for the particular views that are usually utilized to visually describe a binding structure and the shape of its components, but not blindly: they are modified and integrated when incapable of conveying all the information needed.

In chapter 4, looking at the different types of drawings found in the literature, it was concluded that schematic line drawings are the most versatile and at the appropriate visual level of abstraction to be used as visualizations of bookbinding structures. The black and white schematic line drawings are set against a white background and only in a few instances some surfaces are filled in with grey to represent a reference element as background, e.g. the board for furniture.

Most visualizations make use of different views of the same structure to communicate all the information recorded in the schema (see Figure 39). These resemble projected views found in mechanical drawings (see an example in Figure 40). However, the diagrams do not follow the strict rules and conventions of technical drawings, because the emphasis is not on the exact representation of one object, but rather of its prototype, and also because they are generated from

---

<sup>414</sup> Eco 1997.

a very limited number of measurements. The series of conventional lines and symbols found in technical drawings — e.g. centrelines for circles, dimension lines, projection lines, etc.<sup>415</sup> — would require a reader aware of the complex set of symbols, and they would clutter the drawings with information that, considering the project's scope, would be superfluous. However, following the commonly used drafting convention for invisible edges, those structures (or part of structures) that would be invisible from the selected view point are drawn with dashed lines (see Figure 41).

For certain elements, the representation of their precise length does not add much information, considering the prototypical nature of the diagrams, and would also impede the immediate comparison between structures of different volumes. In such cases, only the extremities of the element are drawn with a faded area in the middle to hint at continuity of the parts. This exploits the Gestalt principle of continuity, compelling the eye to move through one object and continue to the other<sup>416</sup> (see Figure 41).

#### 6.2.3.I. LEVEL OF ABSTRACTION AND SEMANTIC ENTRY POINT

In the schema, there are instances of descriptions that do not convey enough information to be usefully or successfully visualized. These are signalled in the visual description graph schemas by a dagger symbol (†). What happens in these cases is that the description does not lead to the correct semantic entry point for the concept being introduced.<sup>417</sup> A useful example to consider is the list of possible kinds of furniture: (i) articulated metal spines, (ii) bosses, (iii) corners, (iv) full covers, (v) plates, (vi) ties, (vii) catchplates, (viii) clasps, (ix) pins, (x) straps, (xi) strap collars, (xii) strap plates. Types *i* to *vi* can not be usefully drawn, whilst *vii* to *xii* can (see Figure 41). By comparing the information that is available for the first group (see Figure 42) with the information for the second group (at least *vii* to *x*) one would notice that these are further subdivided into more specific typo-

---

<sup>415</sup>. Willard 2009.

<sup>416</sup>. Koffka 1935.

<sup>417</sup>. Jolicoeur *et al.* 1984, see chapter 3.

## 18.3ig - left board

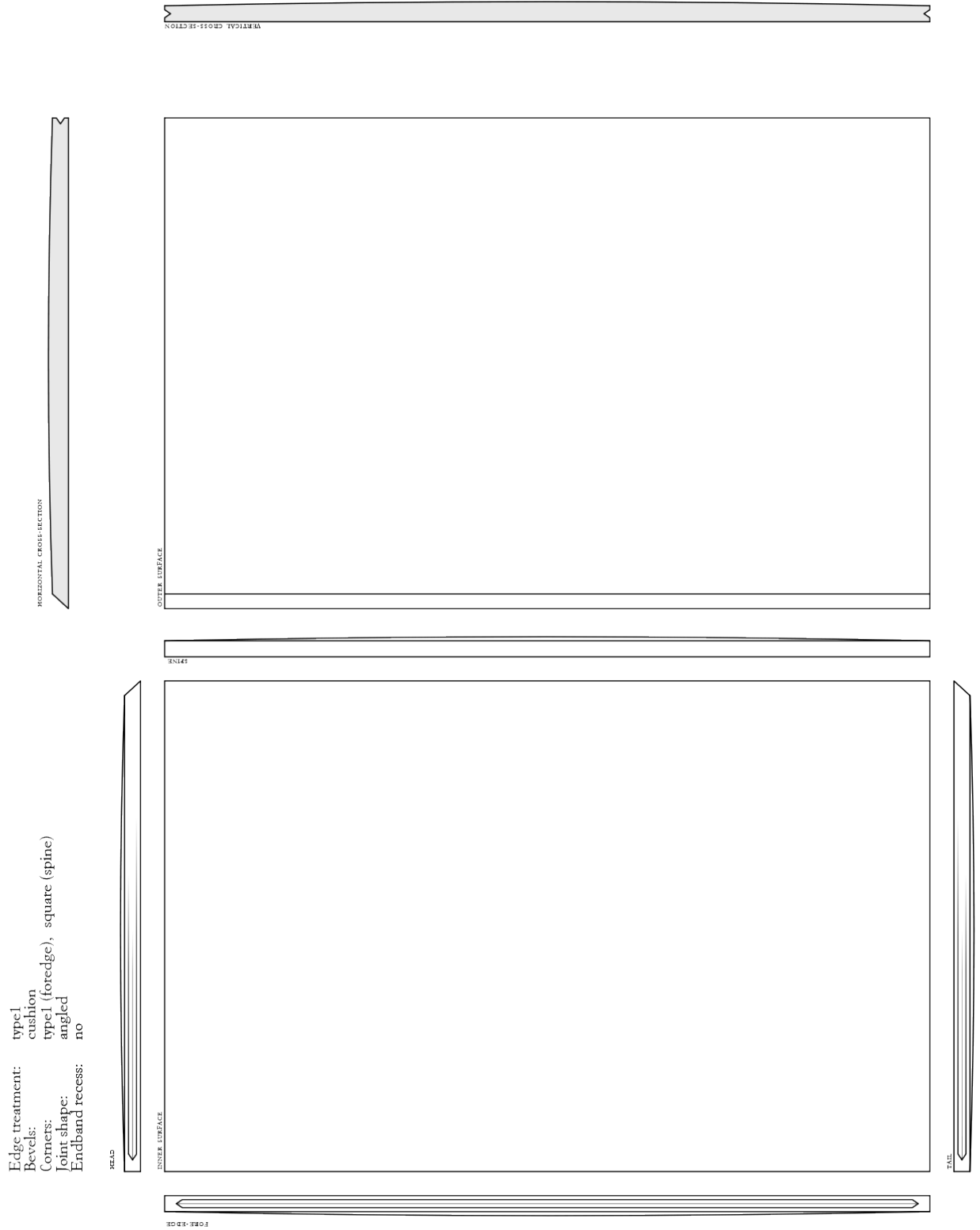

Figure 39. Complete visualization of the left board for Vol. 18.3ig. Note the series of different views: head, inner and outer surface, tail, fore-edge, spine, horizontal and vertical cross-section.

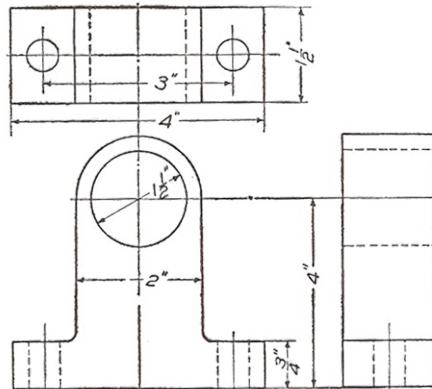

Figure 40. Example of mechanical drawing with three projected views (Willard 2009, fig. 58, p. 63).

## 19.1δ - spine profile

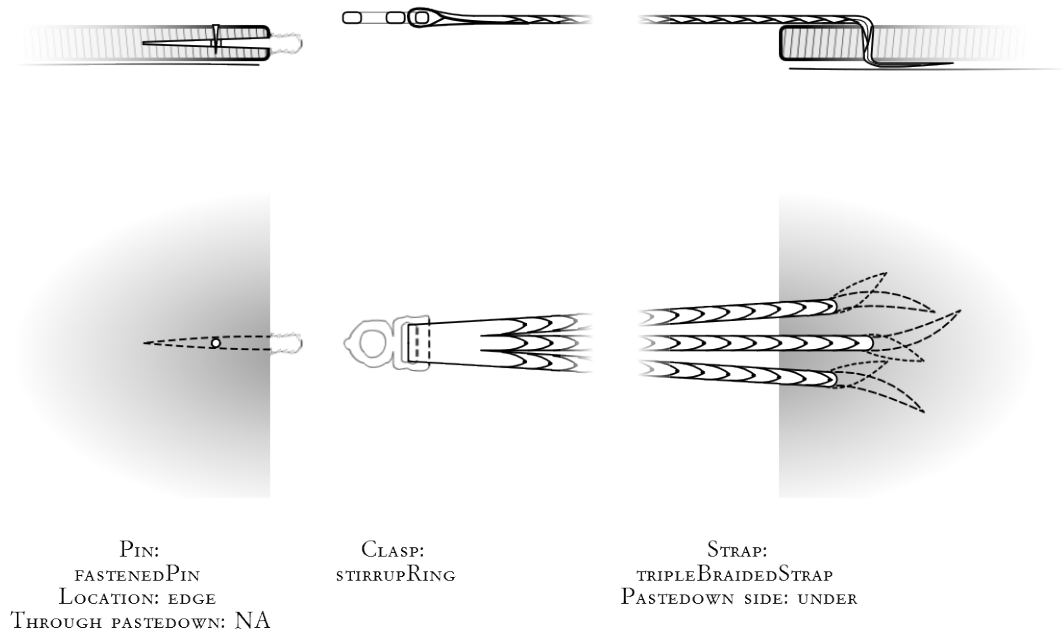

Figure 41. Complete visualization of the fastenings for Vol. 19.1δ. Note the faded area in the strap visualization and the dashed lines for invisible edges.



logies. Each subcategory type comes with a specific definition that provides details about its functional components. Another solution would have been to describe each main typology according to a set of components, but because the number was limited, a specific term carries in itself enough information to allow for a diagram to be distinguishable from others, and specific enough to resemble the original in its formal and functional components. Type *xi* and *xii*, are a particular case because, whilst not further subcategorized, they form in fact a category on their own — that of a metal fixture at the end of a strap — of which each of them is in essence a subcategory, and the definition of their descriptive naming term carries information on their spatial and formal characteristics.

The same is not true for articulated metal spines, bosses, corners, full covers, plates, and ties. Whilst these do hold some additional information in the schema, this does not concern their material components or their form, but rather their making. There is information about the material they are made of and how this was worked, and, as for other furniture, whether they go through the pastedown or not. In addition, bosses' profiles are further described by means of hand drawings, and not as XML data, and, therefore, they are not usable for this project (see Figure 43 for some examples of bosses constructions). The terms describing these furniture types are indeed the basic level of abstraction for their category — i.e. bookbinding furniture — but, as predicted, this is not usually a good semantic entry point for a visual representation, which needs to be a step down towards the particular. Arguably, *i* to *vi* could have been rendered with general shapes, but this would have added little useful information: all books with bosses would have had the same drawing, adding nothing to a simple search of the database for the word 'bosses'. For this automated visualization methodology to be usefully applicable, more information about their material components and form would be needed.

#### 6.2.3.2. DIAGRAM ELEMENTS

For each visualization, there are two main kinds of elements: the proper diagram elements that, when read by the reader, can signify the binding structure described

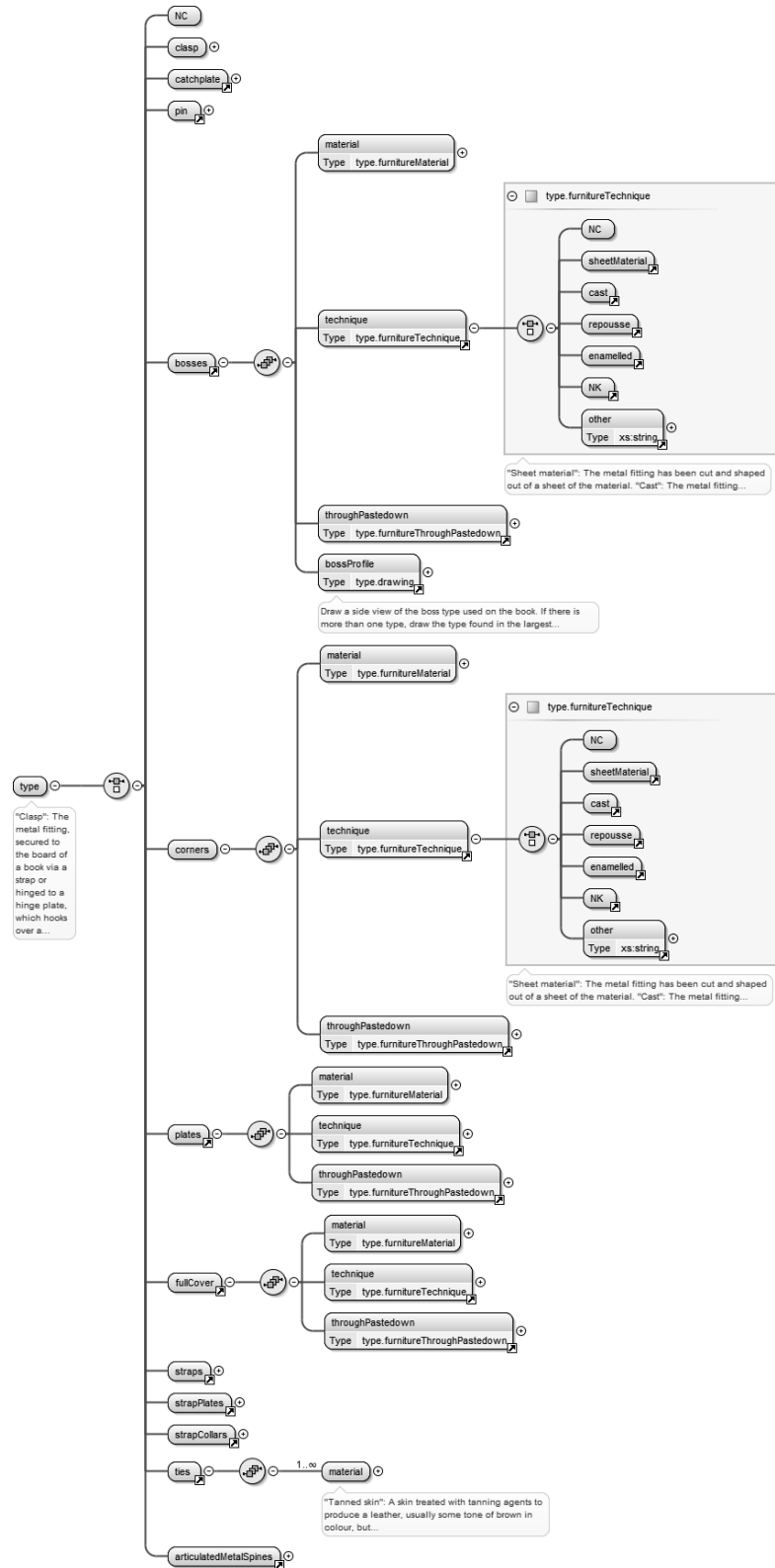

Figure 42. Visualization of the *Ligatus* schema: available information for furniture deemed not drawable or not worth visualizing.

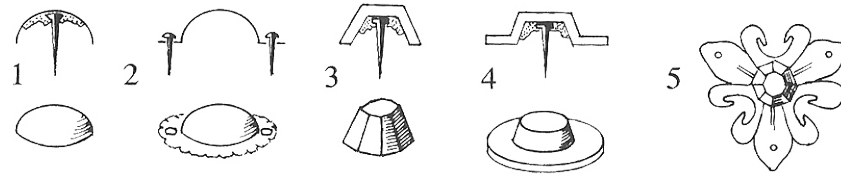

Figure 43. Examples of bosses found in Gothic bindings (Szirmai 1999, fig. 9.55[1-5], p. 264). Note how more complex the description of bosses could be and how their peculiarities are not simply linked to the overall shape of the dome.

in the database, and a set of reference elements. The latter are not mentioned in the descriptions, but help to put each element of the structure visually in context, thus facilitating their signification and allowing for *beta reading modality*<sup>418</sup> of the diagram elements. Reference elements are also designed to be visually less prominent, by greying them out or thinning their lines.

#### 6.2.3.3. SPATIAL ARRANGEMENT

In the diagrams, each component is clearly kept distinct from the others by keeping them all spatially separated by a standard distance. This causes complex structures to extend outward from the centre of each unit and from the reference elements (see Figure 45). This convention makes it easier to identify similar structures, and to understand the role of each component. Consider for instance the examples [g] and [h] in Figure 44 and note how the various components are drawn very close to each other at the fold. In example [h] this is a consequence of the naturalistic nature of the drawing. In example [g], whilst the drawing attempts to be symbolic, the distance between the components is still kept to a minimum to try to attain a more naturalistic appearance. Inevitably, the author is forced to fan out the structure to be able to convey the whole structure more clearly. However, the closeness of the lines of different components causes them to be perceived in close relationship. This is due to the Gestalt principle of proximity: objects near each other tend to be grouped together whether in relationship or not.<sup>419</sup>

<sup>418</sup>. Eco 1997 p. 336.

<sup>419</sup>. Koffka 1935.

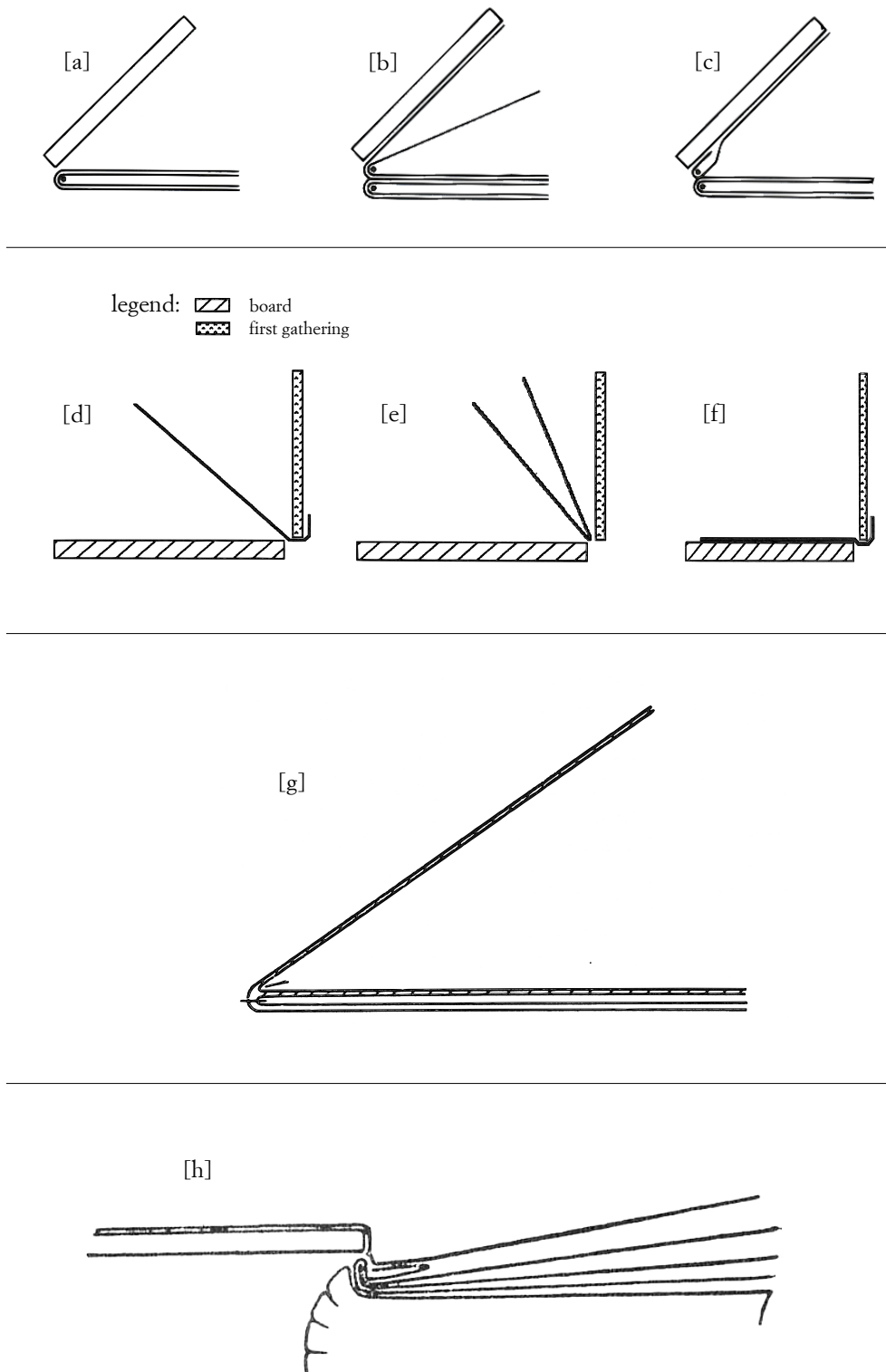

Figure 44. Examples of schematic endleaf diagrams in the literature ([a-c] Szirmai 1999, fig. 8.4[a,c,g], p. 147; [d-f] Carvin 1988, p. 34[0A,0B,1A] — the legend has been translated from the original French; [g] Middleton 1996, fig. 26, p. 43; [h] Cockerell 1953, fig. 19[v], p. 81, this example tends more towards naturalism).

Moving each component and unit outward avoids the risk of perceiving stronger relationships where a weaker one would be needed to understand the structure. This happens at the expense of naturalism, but it offers more clarity and communicability, which is a worthy trade off (see Figure 45).

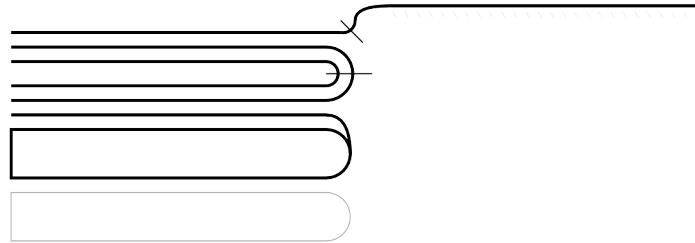

Figure 45. Example of a complex endleaf structure with both integral (one leaf) and separate (two units) endleaves (Vol. 4725.3162). Note how the units and components are moved outward, away from the reference gathering.

#### 6.2.3.4. THREAD PATHS

Thread paths move and link elements in three dimensions. Diagrams always show two-dimensional views. Whilst this is not generally a problem for sewing diagrams, endband cross-section views present some issues.

Cross-sections of endbands are used to show the relation of cores and the bookblock, but also to show the path of the thread around the cores and inside the quires. In these visualizations, the third dimension (along the length of the endband) is not shown and therefore it is impossible to depict how it moves along the endband core (see Figures 46 and 47). In Figure 46[e1] this convention is not followed, but the result is rather cumbersome.

Manuals of how to work endbands make scarce use of these cross-sections,<sup>420</sup> or do not use them at all,<sup>421</sup> whilst they are common in articles and monographs on the history of bookbinding. The established convention of drawing the endband in two dimensions is followed here, as these diagrams are not meant to instruct how to work endbands. The diagrams act as a way to visualize with as few lines as possible the essence of the thread path and the endband sewing. Complex

<sup>420</sup>. Greenfield 1990.

<sup>421</sup>. Bibliothèque Nationale (France) 1989.

structures become difficult to follow in these diagrams (e.g. Figure 47 [f] and [g]), however, the diagrams as a whole can act as a symbol for the structure. In fact, once encountered, given the distinct appearance of each path and the limited number of options visualized,<sup>422</sup> these are easily memorized and recognized as a whole, without having to discern the path of the thread. Like all diagrams produced in this project they are ruled by *ratio difficilis*,<sup>423</sup> as the organization of the expression is determined by the organization of the content — i.e. they are visually similar to what they represent — however, as representations of types, they also constitute preformed expressions — i.e. one these types of endband thread path diagram will always be represented in the same general manner — and can thus also be considered as ruled by *ratio facilis*.<sup>424</sup>

#### 6.2.3.5. UNCERTAINTY

As outlined in the previous chapter, when dealing with data on historical bookbinding structures, one has to accept that a degree of incompleteness, uncertainty, and imprecision is inevitable. Given the particular nature of the automatically generated diagrams for this project, this has to be generated parametrically and applied without modifications to the overall design.

Ideally, one would not want to draw components which are not accurate, but this is not possible because leaving out the inaccurate part of the diagram leads to misunderstanding, and potentially it could make the whole diagram meaningless. This is because the operation would leave gaps in the plane of the diagrams, and *zero signs* would still be read as absence of phenomena, and not as missing data.<sup>425</sup>

For example, let us consider the case of double hooks (see Figure 48). As it will be seen in detail in the next chapter, this type of hook is always drawn as being formed out of a conjoined bifolium. However, since the information provided is not sufficient to rule out the case of it being made out of two separate sheets, the

---

<sup>422</sup>. The schema distinguishes between seven different types: warps only, no bead, front bead, no front bead, reversing twist, Greek single core, and Greek double core.

<sup>423</sup>. Eco 1975/2008; See chapter 3.

<sup>424</sup>. Eco 1975/2008.

<sup>425</sup>. Bertin 1983/2011.

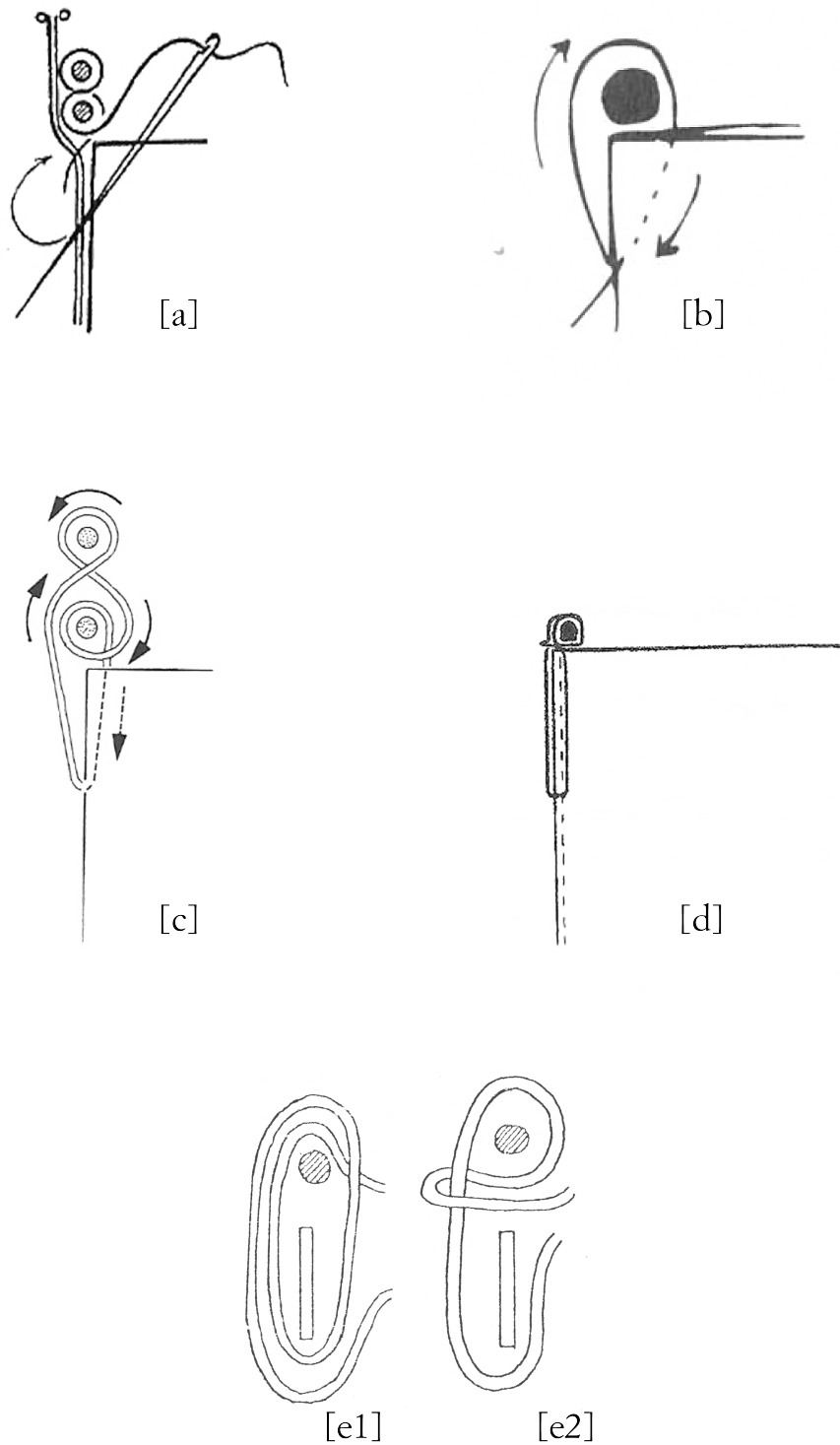

Figure 46. Examples of cross-section visualizations for endbands found in the literature. ([a] Jäckel 1975, fig. 3, p. 210; [b] Greenfield 1990, p. 59; [c] Szirmai 1999, fig. 6.10[c], p. 77; [d] Clarkson 2005, fig. 17, p. 16; [e1-2] Conn & Verheyen 2003b, p. 1).

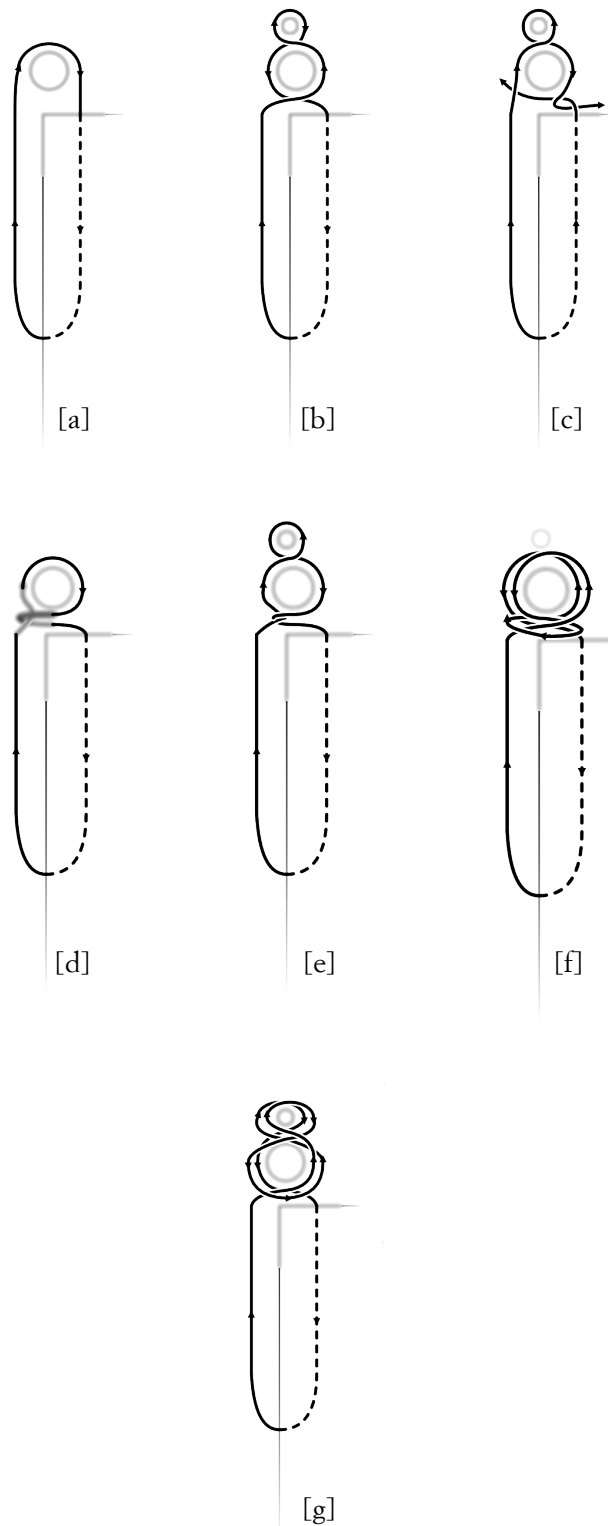

Figure 47. Examples of cross-section visualizations for endbands: [a] warps only (Vol. 219); [b] no bead (Vol. 3793.2703); [c] front bead (Vol. 4820.3212); [d] no front bead (Vol. 221.105 $\alpha$ ); [e] reversing twist (Vol. 2938.2149); [f] Greek single core (Vol. 2525/1814); [g] Greek double core (Vol. 2329.1633).



conjoined portion is drawn as uncertain. If one were to leave out the uncertain portion of the diagram, the diagrams would always show a hook made of two separate sheets, which might be true in some cases, but certainly not always.

Let us consider now the case of an endband cross-section diagram for which some information is uncertain (see Figure 49). The sewing structure for this particular endband is described as *no-front-bead* to indicate that no front bead was present, but also that it was not possible to check for the presence of the back bead. Also, the schema does not have information (in XML format) in regard of the preparation of the gatherings for the endband and the shape of the endband core cross-section: the gatherings are always drawn as not cut at head or tail to accommodate the endband and give cores as circular cross-section shapes, but these are indicated as uncertain. If, as in Figure 49 [b], one were to remove all uncertain information, the diagram might only show true and certain information, but it has no meaning and becomes useless.

As a general rule, for this project, there are two main ways of showing that some data is uncertain: blurring, and fading. In the examples so far, blurring was used as the means of dealing with uncertainty.

Eco<sup>426</sup> and Saint-Martin<sup>427</sup> both point out how images are macroscopic blocks of information whose meaning is identifiable with pertinent units, but these are not independent and are essentially *continuous* as they cannot usually be considered in isolation. For these reasons, the application of uncertainty needs to always take into consideration how each unit relates to the others in their block of information. We have seen how simply deleting them is not an option, and blurring becomes a feasible way of showing both the shape to be read to keep the overall meaning and highlight uncertainty at the same time.

There are cases when deleting uncertain information does not necessarily result in the loss of the meaning of the whole information block. For example, sometimes, it is possible to identify precise boundaries for a unit. If the uncertain information happens to coincide with the extremities of this information block with clear boundaries, deleting the uncertain information does not result in a nonsensical

---

<sup>426</sup>. Eco 1975/2008.

<sup>427</sup>. Saint-Martin 1990.



Figure 48. Detail of right endleaves of Vol. 2177.1482 (see Figure 72 for the whole diagram) with uncertainty regarding the conjoined leaves of the double hook.

drawing. In these cases, one can avoid drawing something that might not be completely or always true by fading the diagram where the information is uncertain (see Figure 50). The schema does not define the typology of the shape found at the end of board grooves towards the spine, nor the measurement of the groove. One could draw the simplest type, a straight cut, and blur it for uncertainty. However, since the end of the groove lies at the extremity of its information block, one could fade it, thus indicating that it is not known how that part is to be drawn, and at which point along the board edge. This way one could avoid drawing something that might be correct only in some cases. The lines are also faded at different lengths to avoid creating visual groups that might be read as coherent and possibly misinterpreted (e.g. a gradually shallower groove).

Interestingly, units that are completely isolated and defined by clear boundaries need to be blurred and not faded off — or in fact deleted as fading off acts by deleting those uncertain parts of a continuous unit — as other units might depend on it for their meaning, and the complete absence of information cannot be flagged as uncertain.

In practice, if the uncertain part to be drawn is connected at both ends with other units, or is a completely discreet unit, this project resorts to blurring to flag uncertainty. When the uncertain part is only connected at one end with other units, that part can be faded off without compromising the overall meaning of the diagram. Both can be easily applied to any shape within SVG, thus allowing for uncertainty to be added to a certain component parametrically when needed. Blurring is the result of a Gaussian blur filter applied to a specific element. The

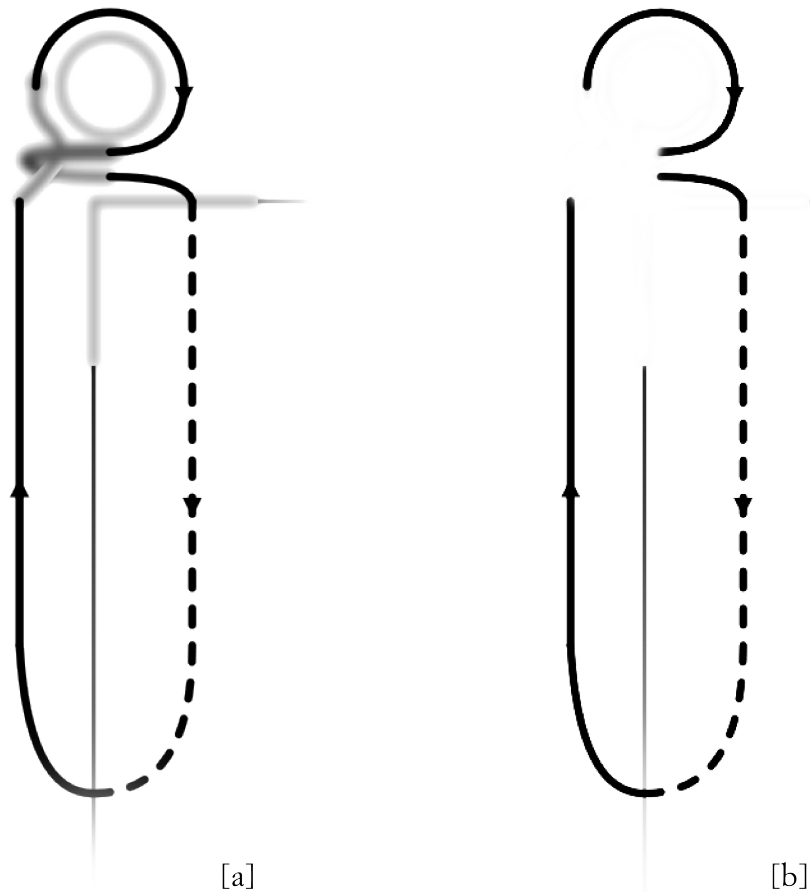

Figure 49. Cross-section of endband with *no-front-bead* sewing description for Vol. 221.105 $\alpha$ . In [a] the diagram is complete with the uncertain information, whilst in [b] all uncertain information has been removed, leaving a meaningless diagram.

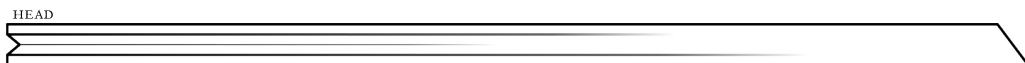

Figure 50. Head view of the left board of Vol. 8.3 $\gamma$ . Note the fading off of the groove towards the spine.

fading effect is given by a gradient fill going from black to white in the appropriate direction.

It should be noted that fading is also used to signal continuing lines when the representation view only requires a portion of the structure or element to be visualized (see for example the boards in the cross-section view in Figure 41). In both cases, fading indicates that the information beyond what is drawn is present but not visualized, either because unimportant, or because uncertain. However, the former is applied to elements that are fixed and always present in all examples of the visualization, whereas the latter is applied to parts that vary from instance to instance. Therefore, confusing the two should not be an issue.

#### 6.2.3.6. ACCURACY AND IMPRECISION OF MEASUREMENTS

The *Ligatus* schema requires that only few measurements are taken from the books: the dimensions of the book, the board thickness, the position of each sewing station, and the measurement of the height of the page at the fold. However, in the diagrams, each line has to be given a certain length. Therefore, an educated guess has to be made for sections that had no direct measurement recorded during the survey. For example, the thickness of the bookblock is given by subtracting the thickness of the boards from the overall thickness of the book, and so forth. In other cases the aim was to keep the proportions between the components correct and meaningful, like the thickness of sewing supports and endband cores. In addition, because of the principle exposed above of moving various components outward to keep them perceptually distinct, but at the same time grouped, some measurements are exaggerated, such as the gaps between endleaves or the board and the endband in greek-style bindings (see Figure 51).

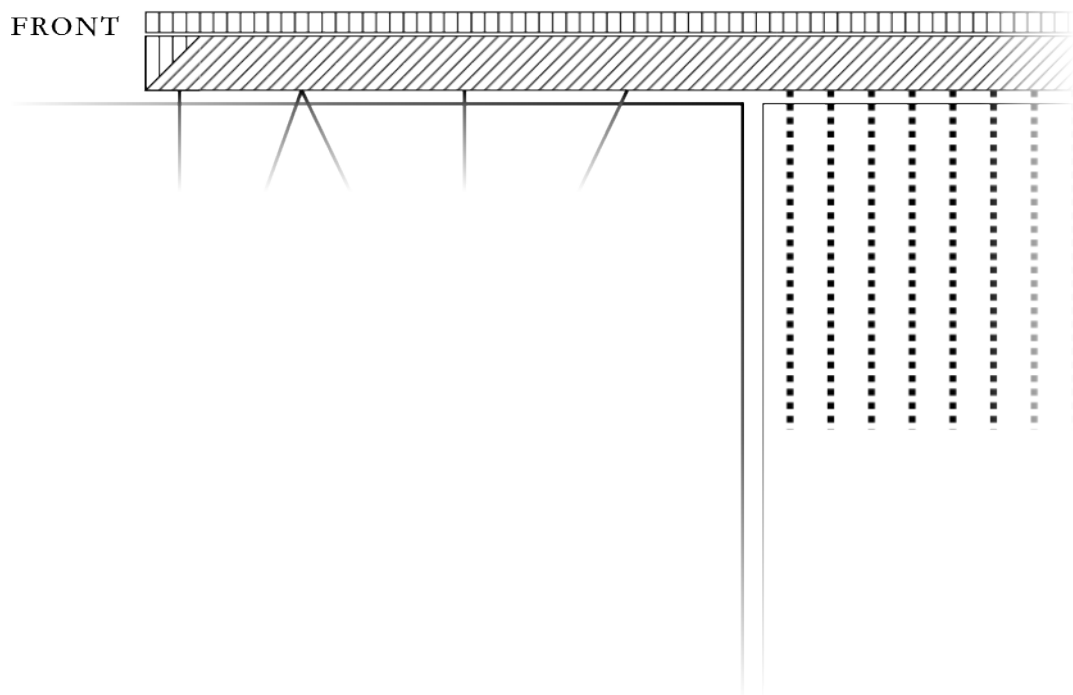

Figure 51. Front view of the double-core greek-style endband of Vol. 2329.1633. Note the gap between the board and the endband, and the smaller one between the two sections of the endband.

In the previous chapters we have seen that not all physical variables are psychologically perceived in the same way, and that small differences between values of physical variables that are not *prägnant* features are not usually noticed. Furthermore, quantities are usually represented continuously in our minds as ratio values as opposed to absolute values.

All this considered, and given the prototypical nature of this project's diagrams, precise and accurate measurement representation is not necessary. In fact, highlighting which measurements are not precise, would result in most lines being flagged as imprecise, making the diagrams cumbersome whilst adding information of little value to their power to communicate.

The only cases in which imprecision is flagged is when measurements are sometimes given and other times not. This happens for the coverage of panels by part of stuck-on endbands. The schema here calls not for precise measurements, but for ratios of coverage in percentage values. It was decided to draw a diagram

even when the data provided was incomplete, by assuming, in such cases, a percentage value of 100%. In order to distinguish between diagrams of books in which the percentage value was given and the others, imprecise stuck-on endband lengths are flagged by creating a halo around the lines in question (see Figure 52).

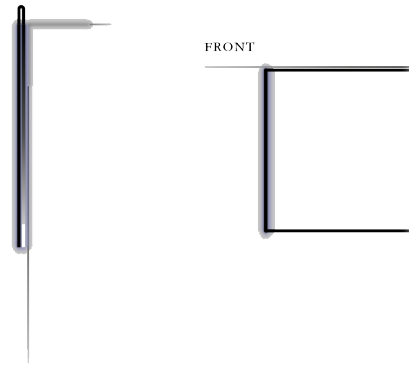

Figure 52. Cross-section and front views of the stuck-on endband of Vol. 2215/1519. In the description the surveyor gave a NK value for the percentage of the coverage of the panel by part of the endband.

A halo is a ‘perceptual distinction’ feature<sup>428</sup> that does not change the shape onto which it is added, and that can be universally applied to graphics through an *ad hoc* series of SVG filters. The reduced contrast with the background makes the feature perceptually less salient, whilst the shape contour is left unaltered. Halo differs from blurring as the line onto which it is applied remains crisp.

#### 6.2.3.7. PLACE-HOLDERS FOR UNCERTAINTY INHERENT IN THE VISUALIZATION PROCESS

One last category of uncertain visualization, as discussed in the previous chapter, is that of components that can be characterized by convoluted contours not constituting any particular function above that of decoration, or components with random and irregular outlines. These are examples of uncertainty that result from the visualization process: these components have been positively identified during the survey, but their translation into a visual language leads to uncertainty. These components are substituted in the diagrams by abstract symbolic shapes, acting

---

<sup>428</sup>. Ware 2013.

as place-holders for the component, but may not resemble what was described, apart from functional parts.

Sketchy lines are used to flag this kind of highly abstract visualization. The sketchy lines are attained by applying a complex series of effects and filters to the SVG shape path.<sup>429</sup>

Figure 53, compares the diagram of a catchplate to a photograph of the same element found on the volume: all the functional elements are present, but the decorative outline of the metalwork is simplified in the diagram.

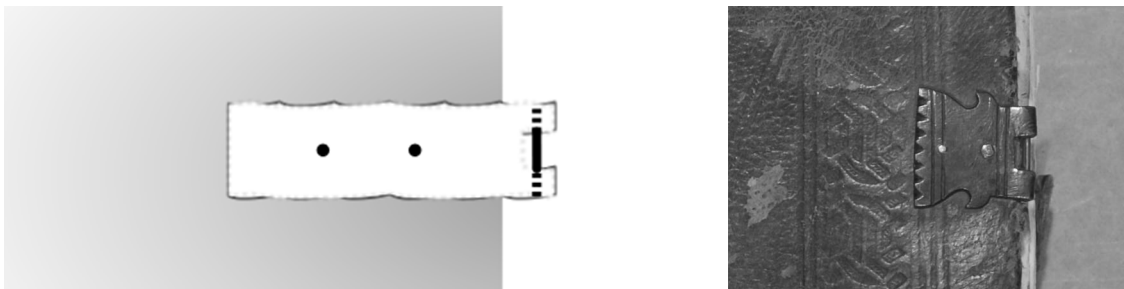

Figure 53. Above view of the roller-round-bar catchplate for Vol. 183.97 (left). The shape of the catchplate could involve complex shapes and is therefore rendered with sketchy lines. Compare with an actual photograph (right) of the volume's catchplate.

One common feature of all of the visual effects discussed in the last few sections is that, purposefully, all follow a modular approach. Each act on a different V1 channel and is cumulative with the others. It would be in fact possible to have, for example, both a component drawn with sketchy lines because of the innate nature of its complex outline and blurred because of uncertainty. For example, patch spine linings are characterized by random and irregular outlines and are therefore drawn with sketchy lines. When a spine lining is described as being only on a selected number of panels, the lining has to be blurred as the schema does not indicate exactly on which panels it has been pasted (see Figure 54).

This modular approach allows the system to be flexible and to always use the same set of visual cues for the same kind of message.

---

<sup>429</sup>. Thanks go to Dr Alejandro Giacometti for his help in the development of this SVG filter.



Figure 54. Example of a diagram that combines sketchy lines and blurring to indicate different kinds of uncertainty.

## Summary

The *Ligatus* schema, at the basis of the dataset, exploits XML's hierarchical nature to create a formalized hierarchical structure for the description of book-bindings. In turn, this project makes use of XML's transferability of data to select and present information in graphic form through other XML technologies, namely XSLT and SVG.

Structures described at the right level of abstraction and semantic entry point are capable of being translated into diagrams. This is true for most structures described within the *Ligatus* schema; the few exceptions will be highlighted in the following chapter.

Data is presented in graphic form — accompanied by verbal labels — following, where possible, the typical conventions of shapes and views found in the literature. New graphic conventions are introduced to ensure correct communication of both material components and form, and to highlight uncertainty and imprecision.

The next chapter will examine in detail the transformation of endleaf structures and introduce more generally all other transformations. A knowledge graph schema will be provided for each transformation.



## Chapter 7. Transformations & analysis

*Yet this little body of thought, that lies before me in the shape of a book, has existed thousands of years [...] To a shape like this, so small yet so comprehensive, so slight yet so lasting, so insignificant yet so venerable, turns the mighty activity of Homer.*

Leigh Hunt, *Among my books*, 1823, p. 22.

This chapter discusses the transformations based on the St. Catherine's description of bookbinding structures. In the previous chapter, the conventions used in all transformations were outlined. As an example, the transformation of endleaf structures is covered here followed by the knowledge graph schema<sup>430</sup> and a general introduction for the rest of the binding structure transformations. Endleaves can be rather complex structures, but are also quite compact in their visualization, making this transformation an ideal example. Appendix C shows the complete set of coding for this transformation.

The last part of the chapter considers the types of human error that exist in the dataset. Empirically, it seems that these errors could be easily identifiable once the erroneous encoding has been visualized. Implementing transformations as outlined in this dissertation can improve data accuracy.

---

<sup>430</sup>. See §6.2.1.

## 7.1. A complete visualization example: endleaves

As seen in the previous chapter, endleaves are found at the front and back of a bookblock. There are two main types of endleaves — *separate* and *integral* — and these types can be combined. There are normally two sets of endleaves and the endleaf structures at either end of the bookblock are not necessarily identical. Any part or parts of the endleaf components can be pasted to the inside of a cover or to the boards after the book is covered. These are referred to as *pastedowns*. The fact that part of an endleaf is used as a pastedown does not alter its identification within an endleaf format, it is simply an additional function added to that binding component.<sup>431</sup> From one description, one can then distinguish between a *structure* visualization that shows the endleaf format regardless of which parts were used as pastedowns and a *use* visualization showing how the particular endleaf format was used in the binding.

### 7.1.1. VISUAL DESCRIPTION FRAMEWORK

Each endleaf visualization is drawn as a cross-section comprising two main parts: the two outermost gatherings as reference elements, and the actual endleaves developing from or on top of the outermost gathering.

Figure 57 reproduces the knowledge graph schema for the endleaf diagrams.<sup>432</sup> Note that the only differences between the *structure* and *use* visualizations are the special case of pastedowns. The description path reaches the pastedown level only in *use* visualizations.

---

<sup>431</sup>. Ligatus 2013.

<sup>432</sup>. As covered in §6.2.1, graph schemas are a graphical representation of the information involved in each bookbinding structure description and transformation. At a glance the reader can appreciate the complexity of a description/transformation, and graph schemas can also be followed, step by step, each node adding a new piece of information, each choice branching in parallel information paths. Graph schemas, in fact, present all the information needed for a description/transformation in one page (or series of related pages for very complex structures).

## 2200.1504 - Left endleaves (Use)

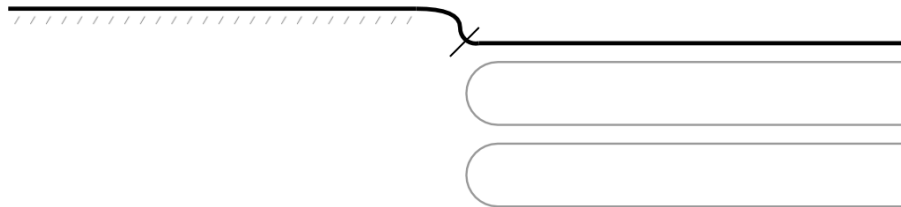

Separate endleaves: unit 1: component 1: fold (pastedown, paper sewn)

Figure 55. Example of endleaf diagram for Vol. 2200.1504: left endleaves, *use* visualization

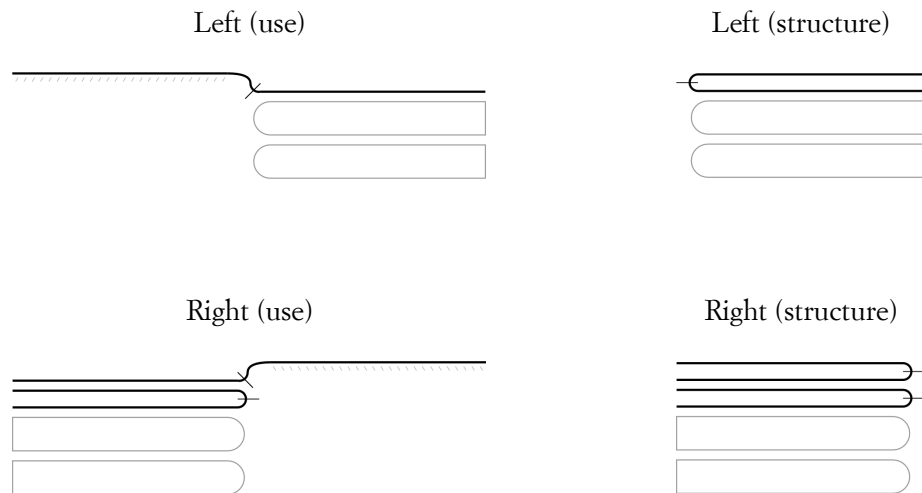

Figure 56. Complete set of endleaf diagrams for Vol. 2200.1504.

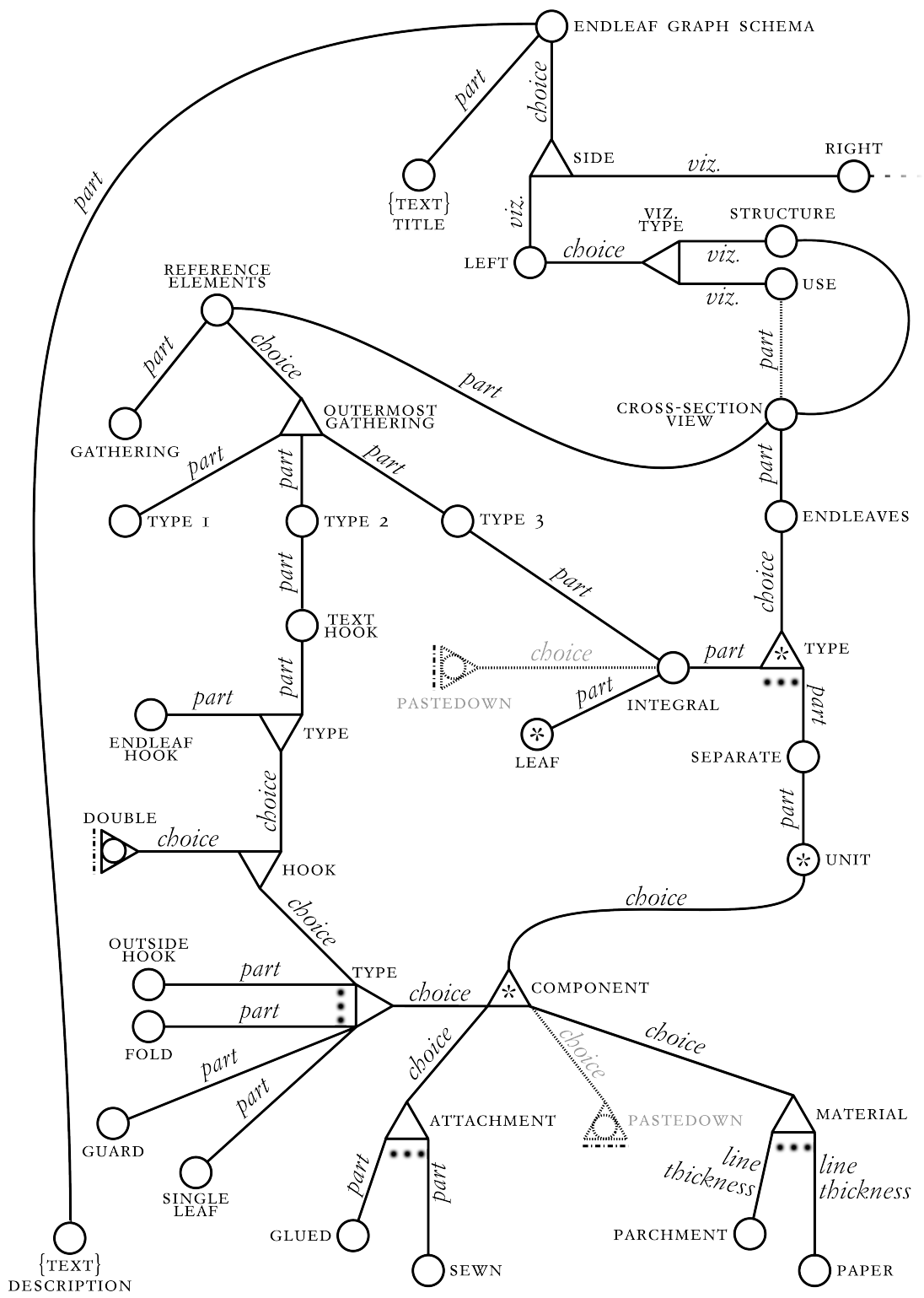

Figure 57. Graph schema for endleaf diagrams (see §6.2.1 for an explanation on how to read graph schemas and their meaning).

## 7.1.2. SHAPES: STANDARD ENDLEAF COMPONENTS

Endleaf structures are drawn diagrammatically in cross-section and in relation to the outermost gatherings.<sup>433</sup>

Endleaf diagrams are composed of three main sets of elements: (i) the reference elements (i.e. two outermost gatherings), (ii) the endleaves, and (iii) their attachment modality.

### 7.1.2.1. REFERENCE ELEMENTS

A single outermost gathering as reference element would suffice for the great majority of endleaf structures. However, for consistency sake, and to accommodate for the rare case of two gatherings sewn through the fold inside a single text-hook endleaf,<sup>434</sup> two reference elements are drawn for all visualizations.

Since these are reference elements, they are, as per convention, drawn as greyed out so to be visually less prominent. However, in the case of integral endleaves, the last gathering is not greyed out. In the case of separate endleaves of the text-hook type, the gathering is shortened to accommodate for the extra leaves around it. However, the shape is not fully parametrical, i.e. it does not become shorter and shorter depending on the number of text-hook components, as it is the case for the endleaf components. This is to keep the element graphically distinct in its appearance and its spatial relationships with the other endleaf components: the gathering is shortened to accommodate for text-hook components, which are set outwards from it, as they usually do in respect to any reference element.

Their shape is closed at the fore-edge to keep them graphically distinct from the endleaves, which are instead open at the fore-edge. This graphic convention helps to distinguish textblock gatherings from the endleaves. In the case of integral endleaves, they are drawn as emerging from the outermost gathering, and kept separate at the fore-edge (see Figure 58).

---

<sup>433</sup>. This projects follow here and is indebted to the convention established by Pickwood for the survey of the volumes of the library of St. Catherine's Monastery (Pickwood & Gullick 2004).

<sup>434</sup>. Ligatus 2013.

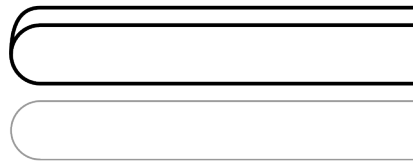

Figure 58. Example of integral endleaves (Vol. 235.114).

#### 7.1.2.2. ENDLEAF COMPONENTS

The graphic representation of all endleaf structures can be thought of as being composed of a very limited set of standard components. For separate endleaves, five basic components can be identified: (i) a fold; (ii) a hook — be this separate from or wrapped around the outermost gathering/s; (iii) an outside hook; (iv) a guard; (v) a single leaf. Hooks can be doubled, i.e. they can be formed by a bifolium folded around to form the hook. Integral endleaves (see Figure 58) are obviously limited to one basic shape: a leaf emerging from the outermost gathering.<sup>435</sup>

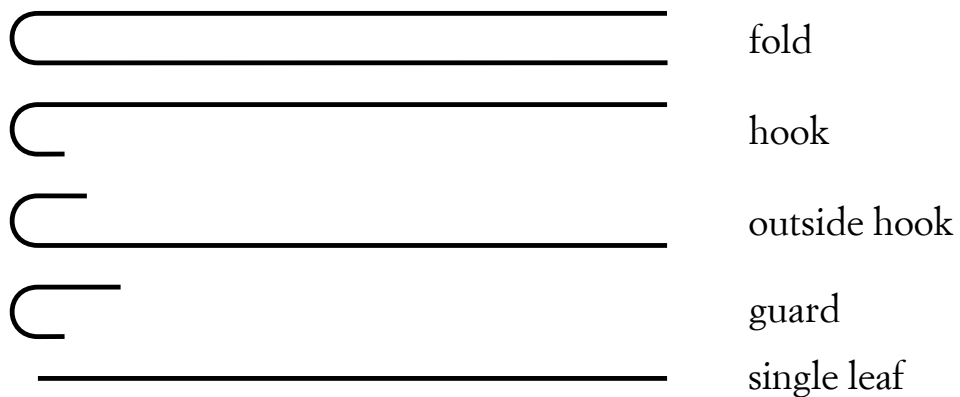

Figure 59. The five basic components of separate endleaves (after Pickwood & Gullick 2004).

#### 7.1.2.2.1. PASTEDOWNS IN USE VISUALIZATIONS

Each of the basic components could be pasted to the cover or boards as pastedowns. In these cases, in the *use* visualizations, they are drawn open as if the

<sup>435</sup>. Pickwood & Gullick 2004.

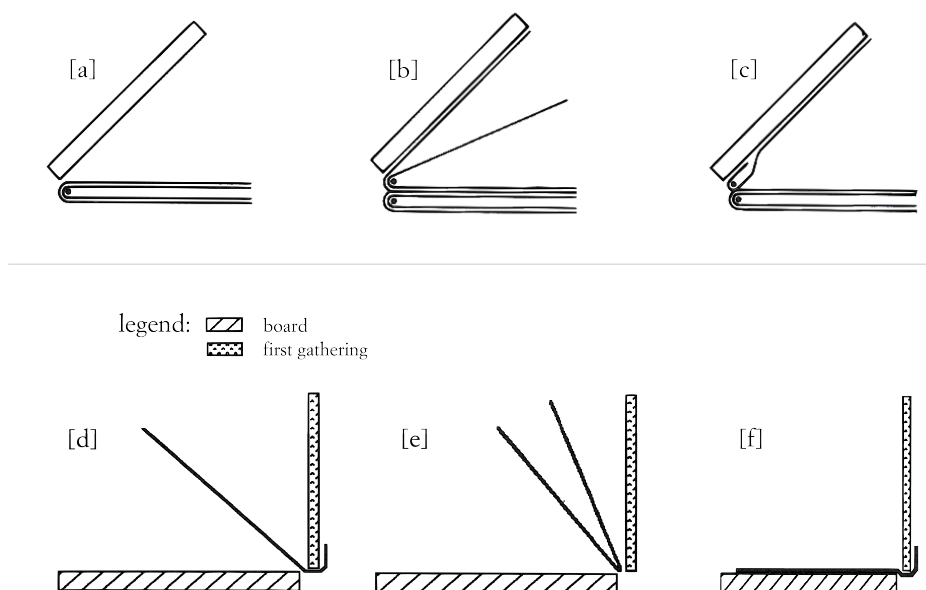

Figure 60. Examples of schematic endleaf diagrams in the literature ([a-c] Szirmai 1999, fig. 8.4[a,c,g], p. 147; [d-f] Carvin 1988, p. 34[0A,0B,1A] — the legend has been translated from the original French).

cover or board onto which they are pasted were open at  $180^\circ$ ,<sup>436</sup> also, a patterned area is added under the pastedown symbolizing the adhesive (see Figures 55 and 56). This convention makes the need to draw the board redundant, leading to less cluttered diagrams; also, opening the endleaves at  $180^\circ$  makes the diagrams more easily comparable and separates more clearly pastedowns from flyleaves (i.e. endleaves that have not been pasted down). Let us compare, for example, this convention with those followed by other authors in the literature (Figure 60). Both Szirmai<sup>437</sup> and Carvin<sup>438</sup> make use of the board as reference element in their drawings and depict the structure as open at  $45^\circ$  or  $90^\circ$ . In particular, Carvin (Figure 60[d-f]) draws the board as flat, the outermost gathering — or the first gathering as he refers to it — straight up forming a  $90^\circ$  angle with the board, the flyleaves open roughly at a  $45^\circ$  angle, and the pastedowns obviously flat and adhered to the board. Szirmai (Figure 60[a-c]) instead draws the board open at  $45^\circ$ ,

<sup>436</sup>. Pickwood & Gullick 2004.

<sup>437</sup>. Szirmai 1999.

<sup>438</sup>. Carvin 1988.

the pastedown adhering to the board, the gathering flat, and the flyleaves either flat or at an acute angle with the gathering.

The convention chosen for this project allows producing less cluttered visualizations. These visualizations are also more flexible as the convention permits to draw complex structures without affecting the overall appearance of the diagram. If one were to visualize complex structures following Szirmai's or Carvin's diagrams, one would have to squeeze these between the outermost gathering and the board that is fixed at 45° or 90°. Whereas, not having a fixed element apart from the outermost gatherings, allows expanding without limit the visualization, and to accommodate multiple endleaf units without having to compress these in a fixed space. See for example Figure 65.

### 7.1.2.3. ATTACHMENT MODALITIES

In separate endleaves, each component is attached to the bookblock by means of an attachment modality: glued or sewn.

#### 7.1.2.3.1. SEWN

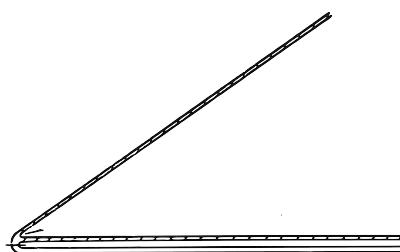

Figure 61. Example of endleaf diagram with sewing thread convention (Middleton 1996, fig. 26, p. 43).

When a component is described as sewn, a short line is drawn from the centre of the unit towards the spine. This symbolizes the thread piercing the endleaves and going out towards the spine through the fold.<sup>439</sup> The same convention can be observed in Middleton's example in Figure 61. Note the different convention

---

<sup>439</sup>. Pickwoad & Gullick 2004.



followed by Szirmai in Figure 60).[a-c] instead, where a single dot at the centre of the fold is drawn to symbolize the presence of the sewing thread. This is taken as representing a cross-section of the thread. However, the convention of drawing the line through the fold represents both the presence of the sewing thread and the action of the thread that keeps the components together — both physically and here visually — by crossing them all at the fold.

#### 7.1.2.3.2. *GLUED*

When components are described as glued, a patterned area is drawn towards the outermost gathering symbolizing the adhesive (see Figures 62 and 63). A similar convention is followed by Middleton in Figure 61).

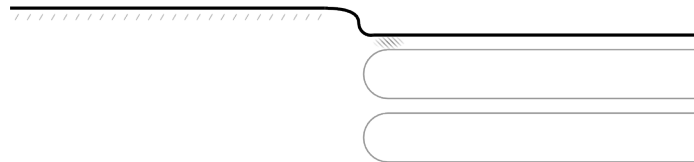

Figure 62. Example of glued component (Vol. 195).

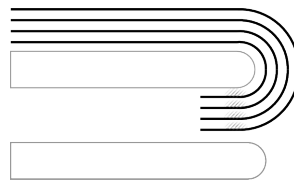

Figure 63. Example of glued components (Vol. 1332.781).

#### 7.1.2.4. COMPONENT MATERIAL

In the dataset, each component can be made of either paper or parchment. These two materials are differentiated in the diagrams by use of a thicker line for parchment components, to help identify and recognize similar structures (see Figure 64).

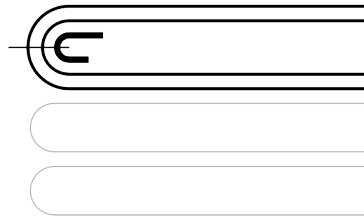

Figure 64. Example of endleaf structure with internal parchment guard (Vol. 1644/1080).

#### 7.1.2.5. SPATIAL ARRANGEMENT

As customary, the elements in the diagrams are kept distinct and spatially separated. This convention was discussed in more detail in the previous chapter (§6.2.3.3).

#### 7.1.3. SHAPES: DIFFERENT TYPES OF ENMLEAVES

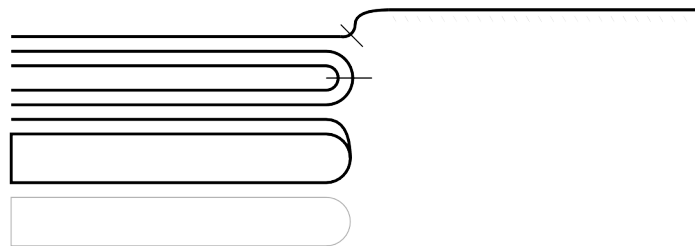

Figure 65. Example of a complex endleaf structure with both integral (one leaf) and separate (two units) endleaves (Vol. 4725.3162).

#### 7.1.3.1. INTEGRAL ENMLEAVES

Integral endleaves are characterized by the number of leaves that are left blank and used as endleaves. The only additional piece of information is whether a blank sheet is used as pastedown or not. Material and attachment modalities do not need to be specified, as they would obviously be the same as those of the gathering to which they belong. Examples of integral endleaves can be seen in Figures 58, 65, and 66.

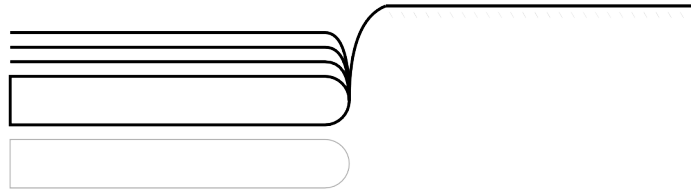

Figure 66. Example of integral four endleaves with one pastedown (Vol. 26.4β).

### 7.1.3.2. SEPARATE ENDLEAVES

Separate endleaf components are differentiated into six different types: single leaf, fold, endleaf hook, text hook, outside hook, and guard. All components, apart from single leaves, are parametrically drawn to accommodate for any other component they wrap around to form a unit.

#### 7.1.3.2.1. SINGLE LEAF

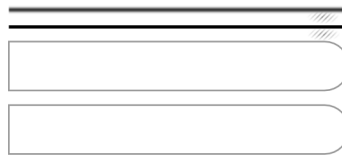

Figure 67. Example of single leaf unit (Vol. 2355.1658).



Figure 68. Example of separate pastedown (Vol. 1651.1083).

A single leaf component is, as the name suggests, a single sheet pasted to the bookblock (tipped leaf) or to the inside of a board or cover (separate pastedown), which is not conjugate with any component in the adjacent endleaf unit. When this constitutes a separate pastedown, it leaves an open joint, i.e. a gap between the pastedown and the bookblock.<sup>440</sup>

<sup>440</sup>. Ligatus 2013.

The graphic representation of single leaves is always limited to its standard shape (see Figure 59). The only parametrical element to their graphic representation within the diagrams is their spatial positioning.

#### 7.1.3.2.2. *FOLD*

A fold component is characterized by a bifolium (two complete leaves). Fold components can be used singly (Figure 56) or in multiples (Figure 69). Each path is split in two halves to allow more granularity with drawing uncertainty. For example, uncertainty regarding pastedowns makes only the upper half blurred.

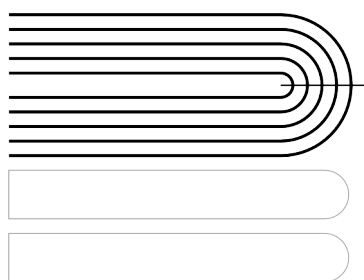

Figure 69. Example of fold components (Vol. 227.107).

#### 7.1.3.2.3. *HOOKS*

Hooks are formed by a single leaf or bifolium of sheet material (double hooks) folded along the spine edge to create a stub on the side of the leaf towards the textblock. Hooks may be used in combination with other endleaf components (endleaf hook) or folded around the outermost text gathering at either end of a textblock (text hook).<sup>441</sup>

##### 7.1.3.2.3.1. *Endleaf hook*

Endleaf hooks are used alone, in multiples, or as a component within an endleaf unit, but are not folded around the adjacent outermost text gathering.<sup>442</sup>

---

<sup>441</sup>. Ligatus 2013.

<sup>442</sup>. Ligatus 2013.

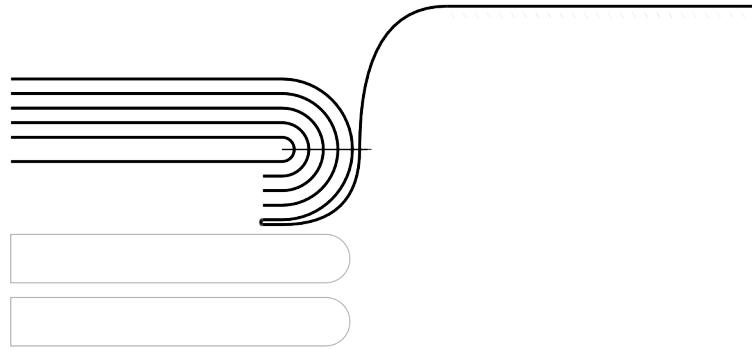

Figure 70. Example of endleaf-hook components (Vol. 2751.1991).

7.1.3.2.3.2. *Text hook*

Text hooks are similar to endleaf-hooks but they are folded around the outermost gathering/s at either end of a bookblock. Very occasionally, two gatherings may be sewn through the fold of a single text-hook endleaf.<sup>443</sup>

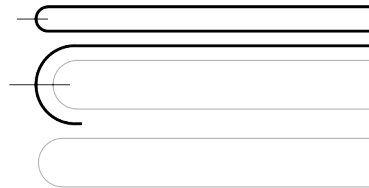

Figure 71. Example of text-hook component (Vol. 103).

7.1.3.2.4. *OUTSIDE HOOK*

Outside hooks are formed in the same way as the other hooks, but the stub they create lies on the outside of the leaf, away from the textblock. Outside hooks can be found used on their own, in multiples or as one of several components within a single endleaf unit.<sup>444</sup>

---

<sup>443</sup>. Ligatus 2013.

<sup>444</sup>. Ligatus 2013.

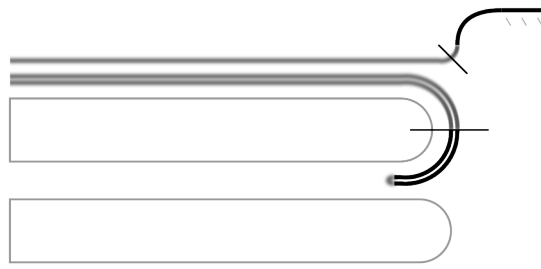

Figure 72. Example of outside-hook component in conjunction with text hooks (Vol. 2177.1482). Note the blurring of the conjoined portion of the double hook. Also, note the blurring of the outside-hook full leaf (see page 194).

#### 7.1.3.2.5. *GUARD*

Guards are narrow strips of sheet material folded lengthways to create two stubs (usually of unequal width, with the wider stub to the outside of the bookblock) and sewn through the fold.<sup>445</sup> See Figures 64 and 73.

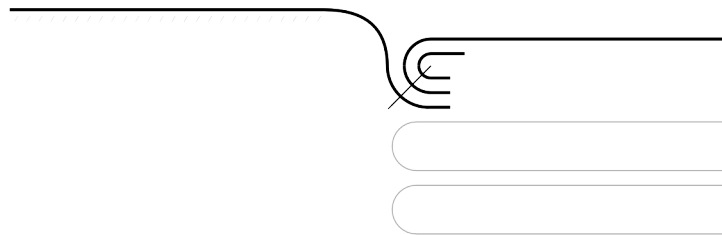

Figure 73. Example of guard (Vol. 3893.2742β).

#### 7.1.4. VISUALIZATION PROBLEMS

The endleaf transformation poses, two main kinds of problems. First, the schema used for the dataset is not always able to convey all the information that would be needed for an accurate visualization: either it lacks some descriptive properties, or it cannot fully deliver the form of the structure, the relationships amongst the elements and their spatial arrangement. Second, comparing the descriptions in

<sup>445</sup>. Ligatus 2013.

the database with the hand drawings of the endleaf structures in the survey forms, one can notice a somewhat poor understanding of the description conventions set by the schema — or their inconsistent application — by part of the surveyors.

These problems are investigated in the following sections.

#### 7.1.4.1. SCHEMA LIMITATIONS

There are two main kinds of limitations in the schema: some are due to the prescribed structure of the description, whilst others are linked to it not encompassing all organizational possibilities.

A first problem is found in the way in which integral endleaves are described. The schema requires the number of integral endleaves in the gathering and whether they have been used as pastedowns. The surveyor can thus only state that at least one of the leaves had been pasted down. In the automated drawings, the algorithm always interprets that only the outermost leaf is used as a pastedown, which is arguably the most probable case. However, the hand drawing done for Vol. 5577.3706a/3706a1 (Figure 74) shows that both leaves had been pasted down, but the survey form did not allow for this.

The schema should instead allow the indication of exactly which leaves are pastedowns.

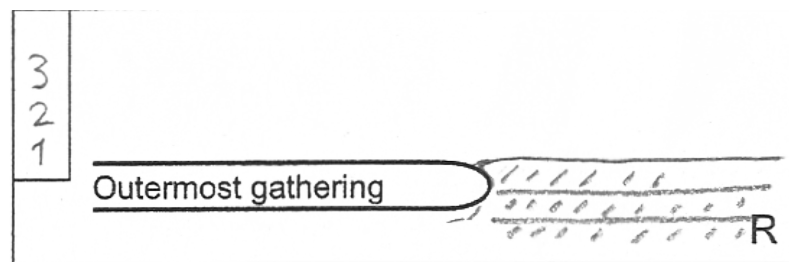

Figure 74. Hand drawing for the right endleaves of Vol. 5577.3706a/3706a1 made during the survey in 2007.

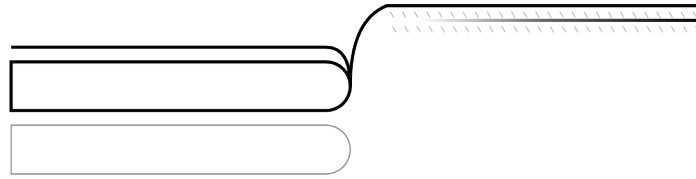

Figure 75. Generated drawing for the right endleaves of Vol. 5577.3706a/3706a1.

Attachment modalities are mutually exclusive — either sewn or glued — which arguably covers the great majority of cases. However, there are examples in the dataset where a component is both glued and sewn. The surveyor had to choose one or the other modality, or add a composite modality for both sewn and glued. There are 38 examples of the latter option.<sup>446</sup> These can be identified through a simple search within the database. However, to accommodate for inconsistencies in the use of the form one has to visually inspect the hand drawings in the survey forms. Compare for example the drawing in Figure 73 and its hand-drawn version in Figure 76.

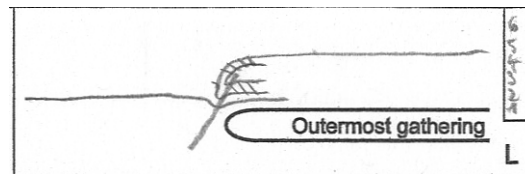

Figure 76. Hand drawing for the left endleaves of Vol. 3893.2742β: note how the guard is drawn as both sewn and glued.

<sup>446</sup> 2172.1477: 'sewn and glued', 2172.1477: 'sewn and glued', 2273/1582α: 'sewn and tipped', 2360/1663: 'glued and possibly also sewn', 2360/1663: 'glued and possibly also sewn', 2388/1691: 'sewn and glued', 2388/1691: 'sewn and glued', 2424/1725: 'sewn and glued', 2424/1725: 'sewn and glued', 2424/1725: 'sewn and glued', 2424/1725: 'sewn and glued', 2515/1805α: 'sewn and glued', 2530.1819: 'glued and sewn', 2542/1830: 'sewn and tipped', 2542/1830: 'sewn and tipped', 2567.1853: 'sewn and glued', 2598.1879: 'glued and sewn', 2878/2096: 'sewn and tipped to text quire', 2938.2149: 'sewn and glued', 2938.2149: 'sewn and glued', 30: 'sewn and tipped to text block', 30: 'sewn and tipped to text block', 3881.2736: 'sewn and glued', 3892.2742α: 'glued and sewn', 3892.2742α: 'glued and sewn', 4051.2825: 'sewn and glued', 4051.2825: 'sewn and glued', 4596.3071c: 'sewn and glued', 4596.3071c: 'sewn and glued', 4598: 'sewn and glued', 5227.3471a: 'sewn and glued', 5227.3471a: 'sewn and glued', 527.268β: 'sewn and glued', 53.13ζ, 14ζ: 'sewn and glued', 53.13ζ, 14ζ: 'sewn and glued', 550.278α: 'sewn and glued', 64.31: 'it is glued to text leaves, then sewn as part of the last quire', 64.31: 'it is glued to text leaves, then sewn as part of the last quire'.



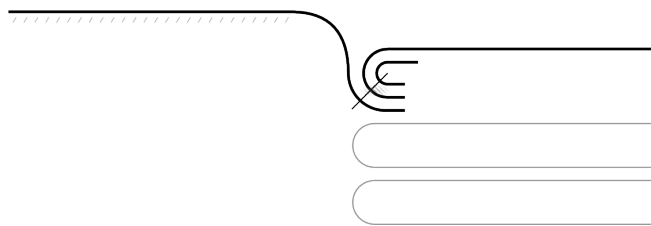

Figure 77. Automated drawing of Vol. 3893.2742 $\beta$  with guard component set as glued.

When a component is described as being glued, the schema lacks the ability to indicate exactly to what the component is pasted. The assumption made in the algorithm is that it is so to the following component or to the outermost gathering. However, looking at the hand drawing in Figure 76, had the guard been described as glued, still the automated drawing would have failed to accurately represent the described structure, as the guard was actually pasted to both leaves of the preceding component (see Figure 77). This leads to another common problem: when single leaf components are also pastedowns, the surveyors have often indicated the component as being *glued*. Looking at the hand drawings it is clear that they meant ‘adhered to the board as pastedown’. Because a single leaf would not extend to the bookblock across the joint, the attachment *glued* option is essentially ignored for separate pastedowns. However, in case of unclear structures, where a component is described as *not known*, *not checked*, or *other*, and its visual representation is a separate pastedown that is faded off towards the fold, the *glued* pattern is blurred and drawn towards the following component or the text gathering. Compare Figure 79 and its corresponding hand drawing (Figure 78).

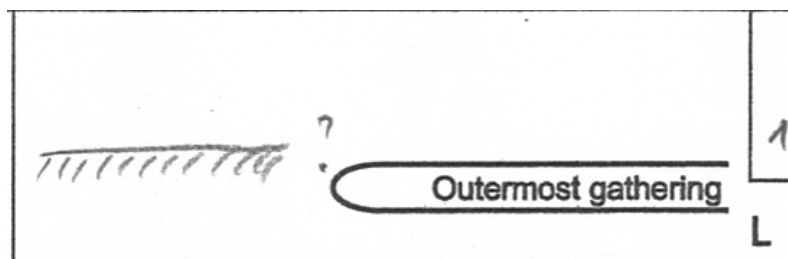

Figure 78. Hand drawing for the left endleaves of Vol. 1648.1082 $\beta$ .



Figure 79. Diagram for left endleaves of Vol. 1648.1082 $\beta$  with uncertain structure and 'glued' attachment modality.

Double hooks can be made either from two separate pieces of paper or a single piece folded twice to create a folded stub out of a conjoined bifolium, but no information is given in the schema in this regard. In the diagrams the conjoined portion of the path is always drawn and made uncertain (see Figures 72 and 80).



Figure 80. Detail of right endleaves of Vol. 2177.1482 (see Figure 72 for the whole diagram) with uncertainty regarding the conjoined leaves of the double hook.

Whilst outside hooks, like the other hooks, and guards can be doubled, the schema does not allow this option. In theory then, these should always be drawn as uncertain, but this would overshadow any other uncertainty, and these were felt as more important than an inaccuracy caused by a schema limitation.

Another problem with outside hooks and guards is that the schema only gives the usual option to indicate that a component was used as a pastedown. Following the usual interpretation, the outer part of the component is drawn as a pastedown. However, there are frequent cases of Dutch endleaves whereby the full leaf has been pasted down, leaving the sewing inside the pastedown.<sup>447</sup> To allow for this, the full leaf is then drawn as uncertain when the hook constitutes a unit on its own (see Figure 72).

<sup>447</sup>. Pickwoad & McKitterick 2013.

There are also cases in the dataset of guards in which both stabs have been pasted down, leaving the sewing inside. To allow for this, the lower stab is drawn as uncertain. Compare Figure 82 and its corresponding hand drawing (Figure 81). A similar problem can be observed for endleaf hooks entirely used as pastedowns (see Figure 84 and its corresponding hand drawing in Figure 83).

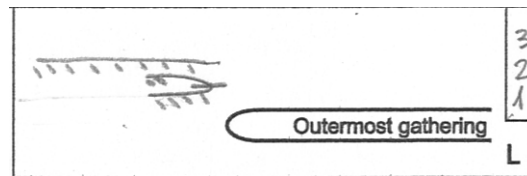

Figure 81. Hand drawing for the left endleaves of Vol. 1628.1067.

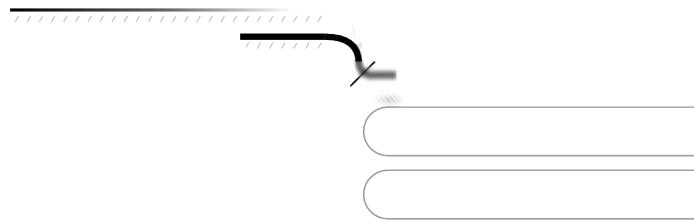

Figure 82. Wrong diagram of left endleaves of Vol. 1628.1067. Note the blurring of the bottom half of the guard and the rogue 'glued' pattern for the uncertain unit.

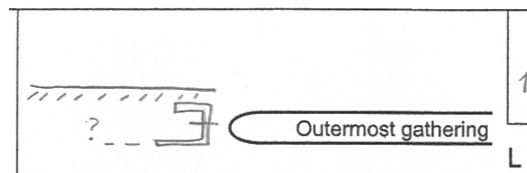

Figure 83. Hand drawing for the left endleaves of Vol. 5400. 3570.

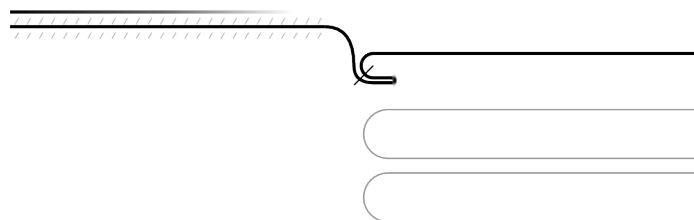

Figure 84. Wrong diagram of left endleaves of Vol. 5400. 3570. Compare with hand drawing in Figure 83.

The schema does not distinguish between endleaf guards and text guards (see Figures 85 and 86). Therefore, they are always drawn as endleaf guards, the most common option. Once again, in theory, guards should then always be drawn as uncertain, at the cost of overshadowing any other uncertainty. As in the case of double outside hooks and guards, it was felt that allowing for the visualization of other uncertainties would be more important than an inaccuracies caused by the current schema's limitations.

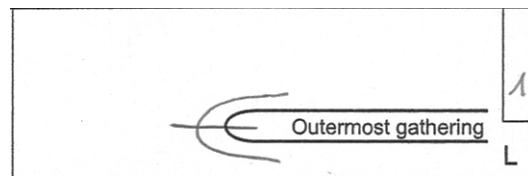

Figure 85. Hand drawing for the left endleaves of Vol. 2529.1818.



Figure 86. Wrong diagram of left endleaves of Vol. 2529.1818. Compare with hand drawing in Figure 85: the lack of a text guard option makes it impossible for this kind of structure to be automatically generated.

#### 7.1.4.2. SCHEMA MISINTERPRETATIONS

If the endleaf structure being described was formed by more than one unit and component, the surveyor was instructed to describe and number them counting from the outside towards the textblock at each end. This was the usual convention that had also been used in the paper forms for the manuscript survey. However, this convention was not consistently followed. In some cases, the surveyor opted to describe the structure starting from the textblock outward.<sup>448</sup> See for example the order of the component numbering in Figure 87.

<sup>448</sup>. Pickwoad & Gullick 2004.

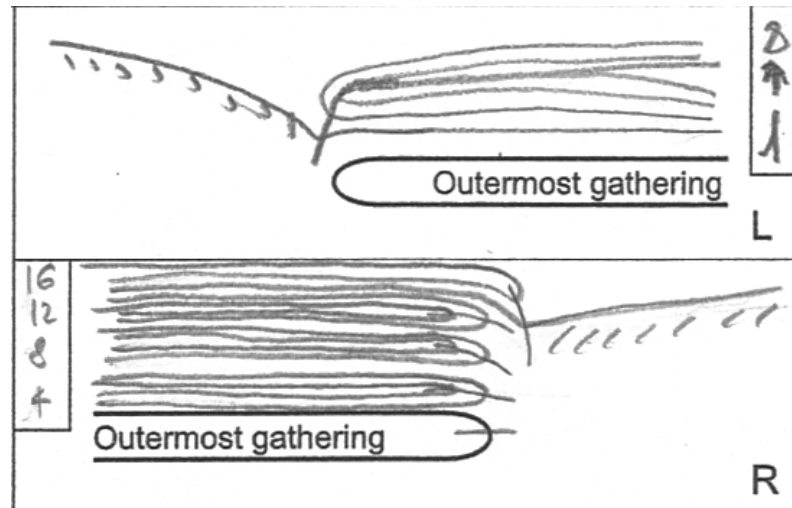

Figure 87. Hand drawings for the endleaves of Vol. 5365.3471d. Note the order of the component numbering.

The elements of the structures being described are all there, but the inconsistencies in their order, can create problems in the interpretation of their spatial arrangement. Whilst a wrong order of components does not usually create problems because of the symmetry of the components' shape, a wrong unit order leads to nonsensical diagrams. See for example the transformations for volume 5365.3471d in Figures 88 and 89, and compare them with the hand drawings in Figure 87. See also how a source XML file in which the order was corrected to be consistent with the schema numbering convention generates a diagram resembling the intended endleaf structure (Figure 90).

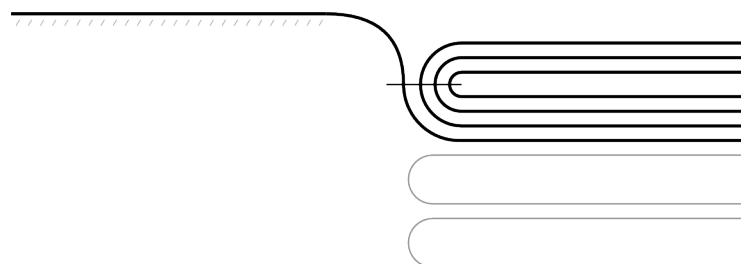

Figure 88. Diagram of left endleaves of Vol. 5365.3471d. Compare with the hand drawing in Figure 87: whilst the order of the components in the description was technically wrong, the symmetry of the components' shape makes the order irrelevant.

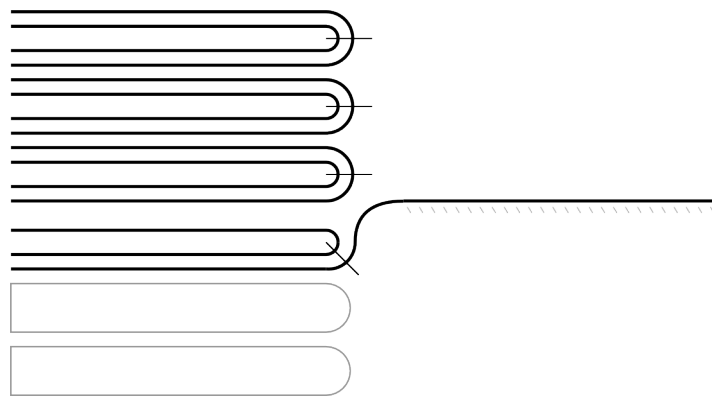

Figure 89. Diagram of right endleaves of Vol. 5365.3471d. Compare with the hand drawing in Figure 87: the wrong order of the various units in the description leads inevitably to a nonsensical diagram with a pastedown in the innermost unit and a series of other units that technically would have had to be sewn through the pastedown.

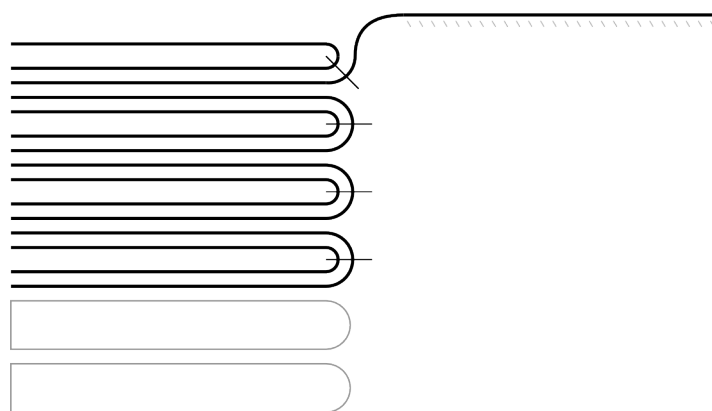

Figure 90. Diagram of right endleaves of Vol. 5365.3471d, automatically generated after the order of the units in the source XML file was corrected to be consistent with the schema numbering convention. Compare again with the hand drawing in Figure 87 and how the diagram now resembles the intended endleaf structure.

Sometimes, the surveyor did not encode the structures properly. According to the schema, an endleaf structure can be of two types — integral or separate — but then, different groupings of separate endleaves should constitute a series of units encoded within the same type of endleaves. Listing 2 shows an XML record that did not follow the prescribed pattern of description: here the endleaf structure has been described as being composed of three types of endleaves, two of which are separate and composed of one unit each. Listing 3 shows what the correct encoding should have been; note also the corrected order of the units. Figure 91 shows the hand drawing for these endleaves, and Figure 65 shows the diagram

generated by the correct XML file. Admittedly, this kind of problem can be avoided through data validation.

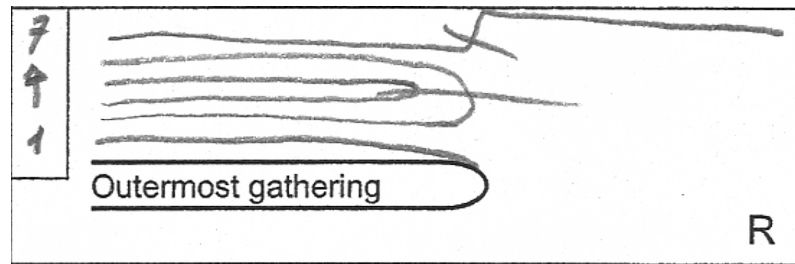

Figure 91. Hand drawings for the right endleaves of Vol. 4725.3162.

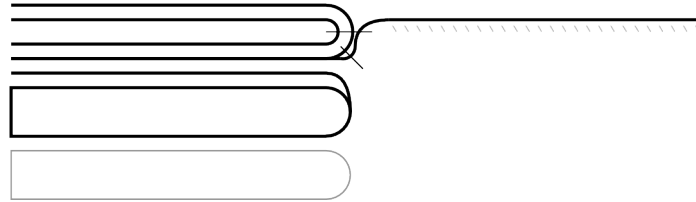

Figure 92. Visual output of incorrect description for the right endleaves of Vol. 4725.3162.

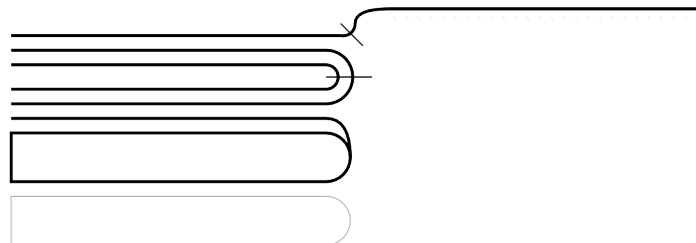

Figure 93. Correct diagram for the right endleaves of Vol. 4725.3162.

```

<endleaves>
  ...
  <right>
    <yes>
      ...
      <type>
        <integral>
          <numberOfLeaves>1</numberOfLeaves>
          ...
        </integral>
      </type>
      <type>
        <separate>
          <units>
            <unit>
              <number>1</number>
              <components>
                <component>
                  <number>1</number>
                  ...
                </component>
                <component>
                  <number>2</number>
                  ...
                </component>
              </components>
            </unit>
            ...
          </units>
        </separate>
      </type>
      <type>
        <separate>
          <units>
            <unit>
              <number>1</number>
              <components>
                <component>
                  <number>1</number>
                  ...
                </component>
              </components>
            </unit>
            ...
          </units>
        </separate>
      </type>
      ...
    </yes>
  </right>
</endleaves>

```

Listing 2. Snippet of XML description for the right endleaves of Vol. 4725.3162. Note the third instance of the **type** element. Three dots indicate elision in the code.



```

<endleaves>
  ...
  <right>
    <yes>
      ...
      <type>
        <integral>
          ...
        </integral>
      </type>
      <type>
        <separate>
          <units>
            <unit>
              <number>1</number>
              <components>
                <component>
                  <number>1</number>
                  ...
                </component>
              </components>
            </unit>
            ...
            <unit>
              <number>1</number>
              <components>
                <component>
                  <number>1</number>
                  ...
                </component>
                <component>
                  <number>2</number>
                  ...
                </component>
              </components>
            </unit>
          </units>
        </separate>
      </type>
      ...
    </yes>
  </right>
</endleaves>

```

Listing 3. Corrected XML snippet description for the right endleaves of Vol. 4725.3162. Three dots indicate elision in the code. The third instance of **type** element has been removed, and the data has been reintegrated within the separate endleaf type, encoding it correctly as a second unit.

## 7.2. The set of transformations

Following the detailed description of the endleaves transformation, this section briefly describes the transformations of other parts of the schema. The complete set of shapes are shown in Appendix B.

Each part of the binding structure has a separate intersemiotic translation, and each transformation is independent from the others. This is important, because, in a future practical application of this work, it would be desirable to run the transformation algorithms during the surveying process, as each part of the structure is being described. There are some cases where information present in the description of some other part of the binding is necessary for an accurate visualization. In the knowledge graph schemas reported here below, these nodes are clearly identifiable as ‘additional information’ and are greyed out. In a future application, this information might be called in as extra parameters to input for the visualization process if not already described elsewhere.

### 7.2.1. MARKERS: PAGE MARKERS, BOARD MARKERS, BOOKMARKS

The schema allows describing three kinds of markers: page markers, board markers, and bookmarks. Page markers are those tabs attached to the edges of leaves in a book to indicate important places in the text. Board markers, as anticipated in the previous chapter, are lengths of animal skin pasted to the inside of the board, projecting from the edge and most probably used as bookmarks. A bookmark is a device used to mark temporarily particular leaves or passages of a book; its formation can range from simple lengths of thread or textile ribbon to multiple elements attached to bars or disks fixed to an endband.<sup>449</sup>

These are rather simple visualizations, as there is only a limited number of parameters to be taken into account. The elements to be drawn are discrete and, for the most part, can be drawn once, called when needed, and then spatially arranged on the plane according to the different visualizations needs. It is helpful

---

<sup>449</sup>. Ligatus 2013.

## 26.4β - Page markers

Type: straight  
Attachment: adhesive  
Location: foredge



Figure 94. Example of pagemarker diagram for Vol. 26.4β.

## board marker

Location: foredgeRight  
Attachment: glued  
Position: overTurnin

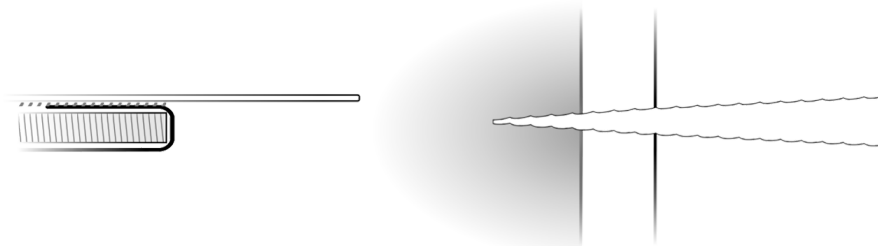

Figure 95. Example of boardmarker diagram. No examples of boardmarkers were recorded in the dataset.

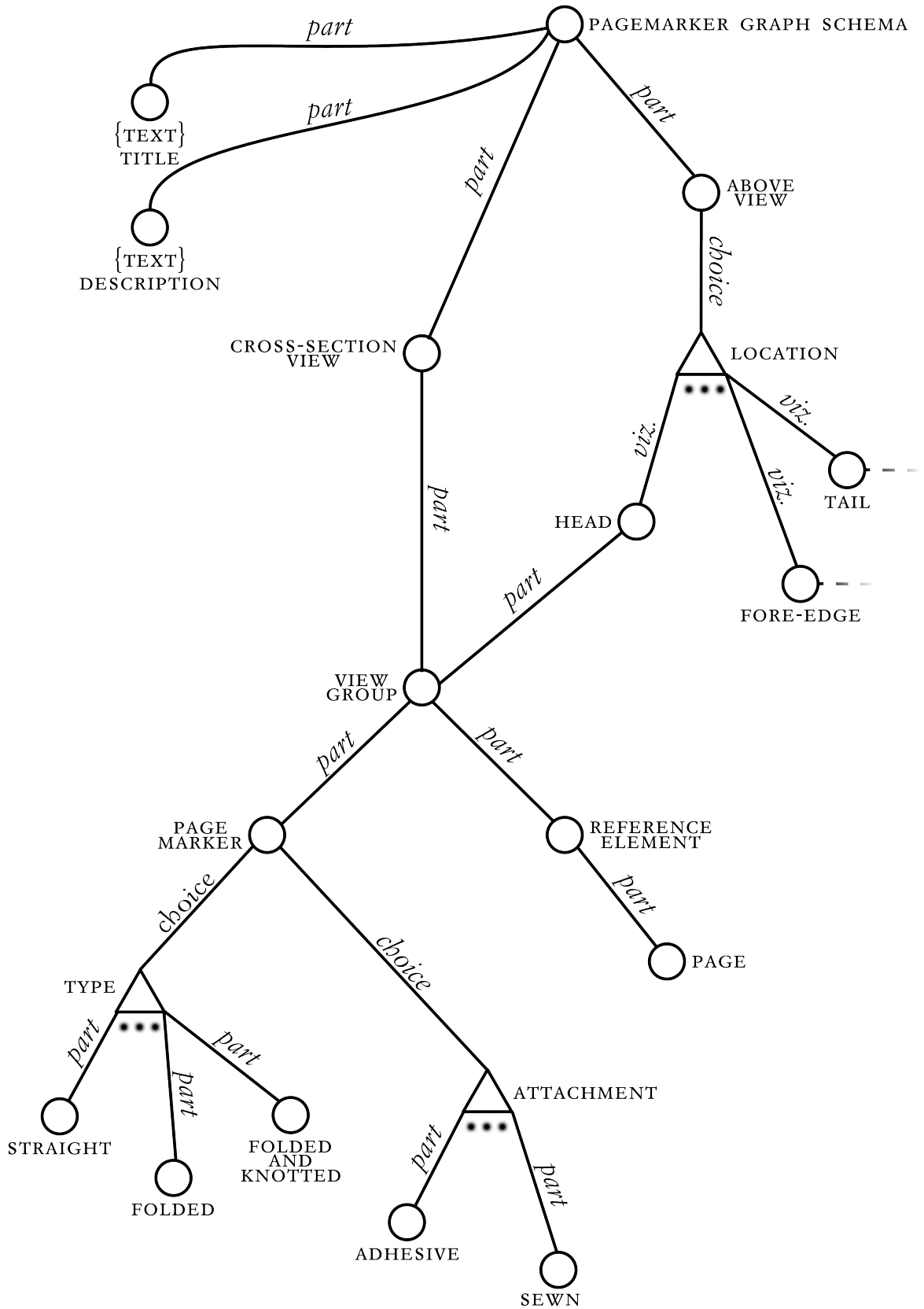

Figure 96. Graph schema for pagemarker diagrams.

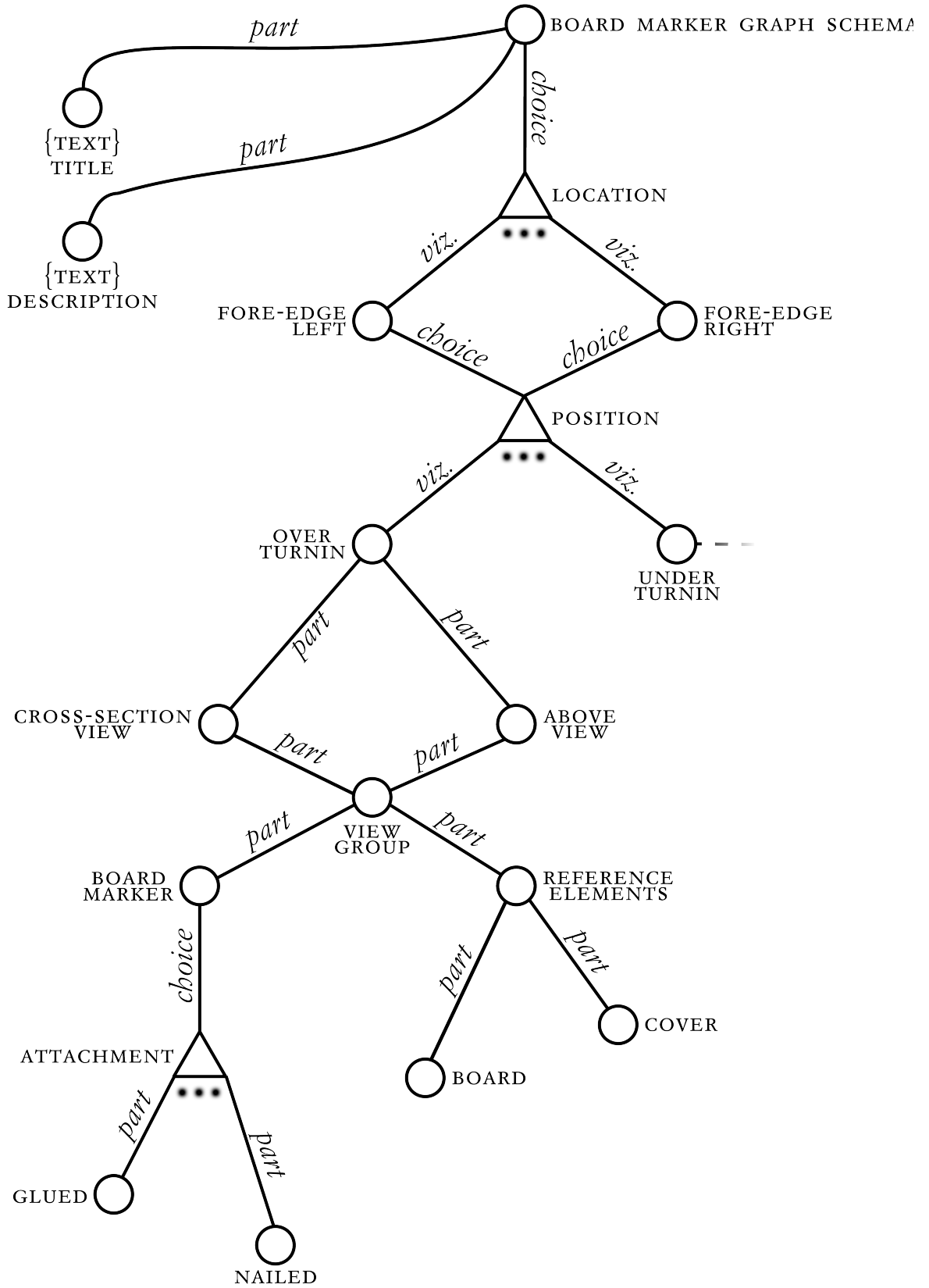

Figure 97. Graph schema for boardmarker diagrams.

# 232.112 - bookmark

Compound bookmark  
Primary type: span1  
Attachment type: knotted  
Secondary type: sewnSingleLength

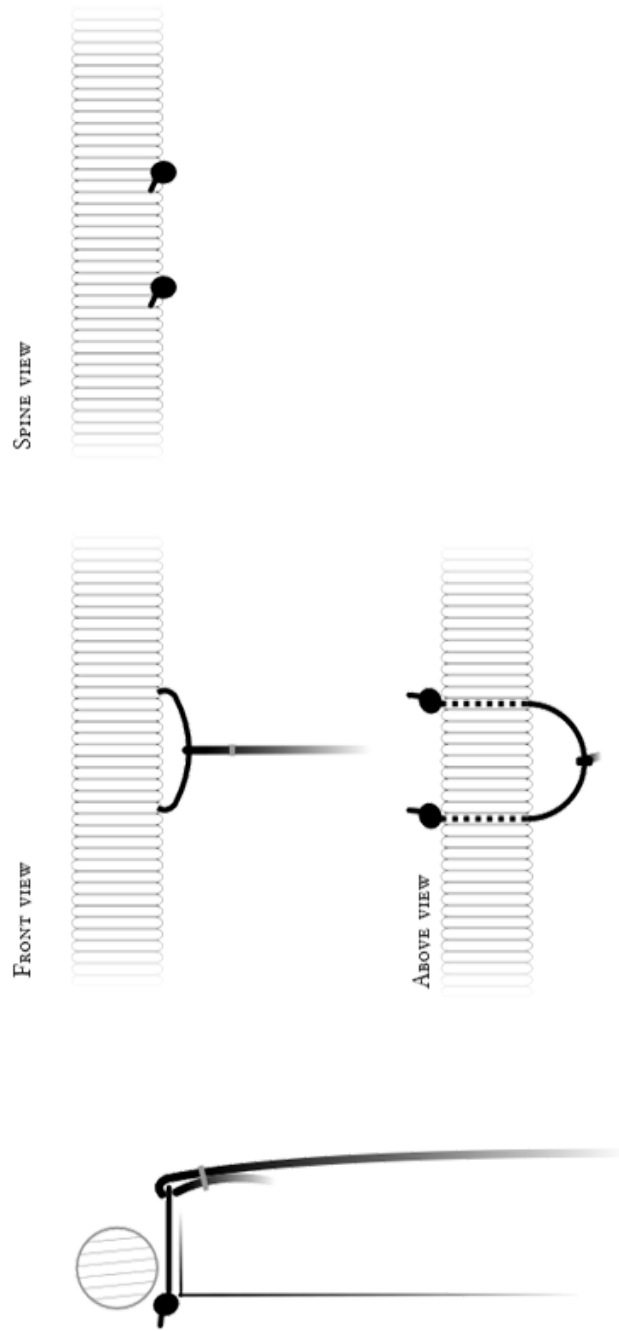

Figure 98. Example of bookmarker diagram for Vol. 232.112.

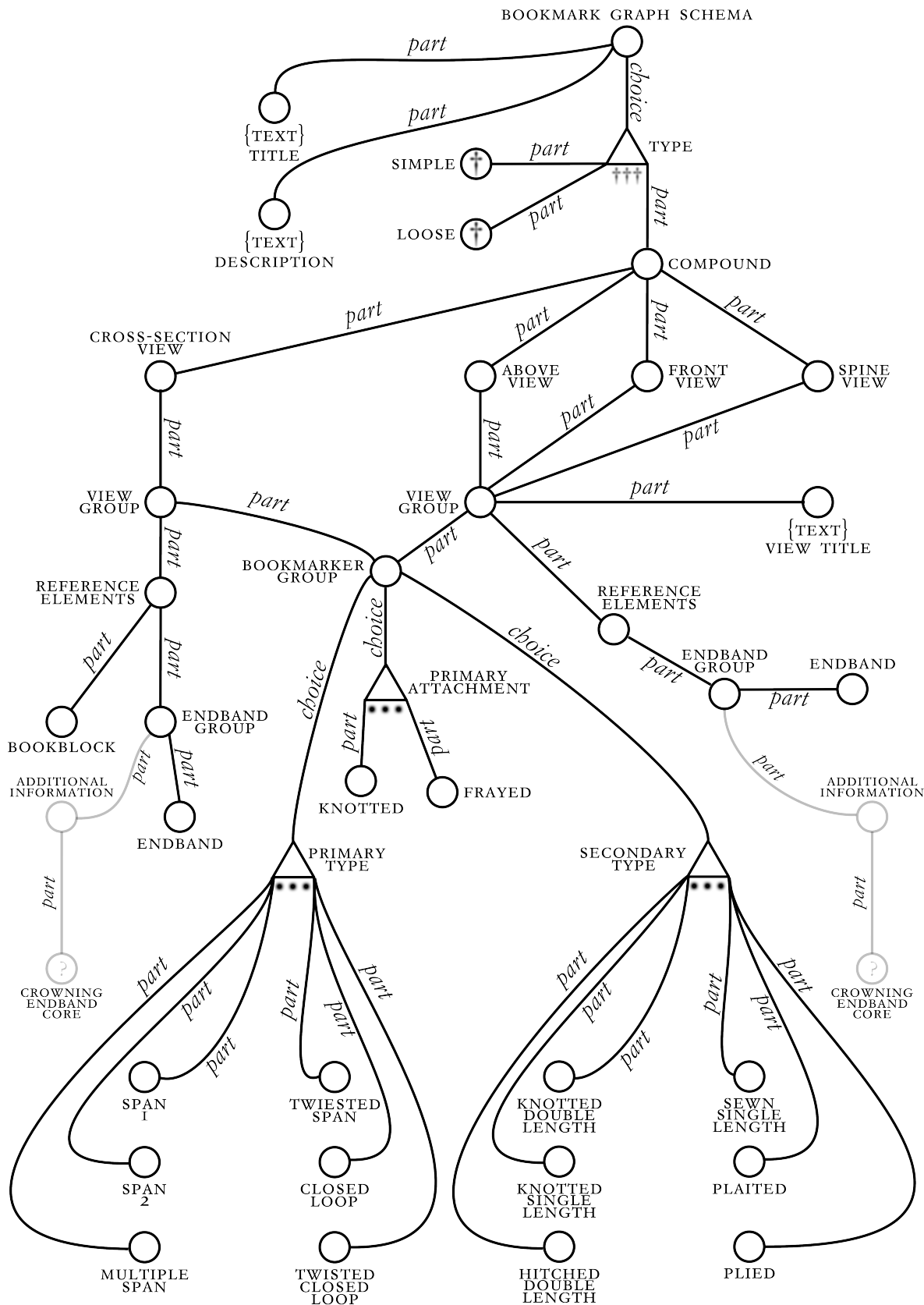

Figure 99. Graph schema for bookmark diagrams.

to note how this approach follows to the letter the need for a one-to-one relationship between verbal labels and graphics. This approach works sufficiently well, when the element being described is only one, and the description only adds details on its position in relation to a fixed series of accompanying or reference elements. This was the case for page markers (see Figure 94) and board markers (see Figure 95). However, when it comes to more complex structures, as are bookmarks (see Figure 95), the maintenance of the code becomes problematic. Because in this approach, the only parameters are the coordinates of each component, changing the graphic output of one component means also having to re-arrange spatially all of the possible components that can be drawn with it. Whereas, by drawing the components algorithmically, these problems can be avoided. It is indeed simpler to write algorithms that work by calling a pre-drawn component, however, due to the difficulties encountered in the maintenance of the code, this approach was for the most part abandoned for the rest of the visualizations.

### 7.2.2. SEWING

Sewing indicates the process through which the sections or leaves of a book are secured by means of thread, thus forming a consecutive and permanent unit.<sup>450</sup>

The basic description element of each sewing is the sewing station, i.e. the individual structural point on the spine-fold used in the creation of the book structure.<sup>451</sup> Each sewing structure is described as a series of sewing stations with a set of specific characteristics. As the sewing develops from station to station, so does the visualization. Books can be sewn and re-sewn various times, and usually this means that multiple sets of sewing stations can be observed. For each sewing station described, the surveyor is asked to specify whether the station is used by the current sewing, or whether it was used in a previous or earlier sewing structure. Typically, only stations of the current sewing can be described in detail, whilst for stations

---

<sup>450</sup>. Roberts & Etherington 1982/1994.

<sup>451</sup>. Ligatus 2013.



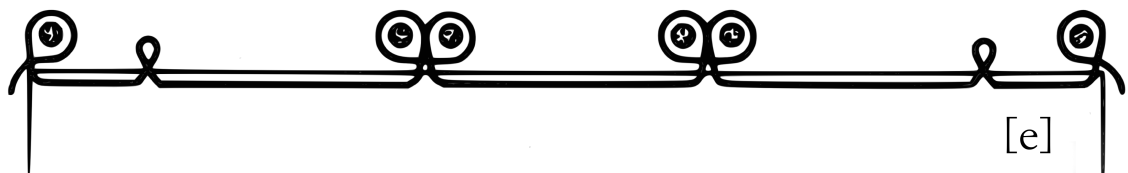
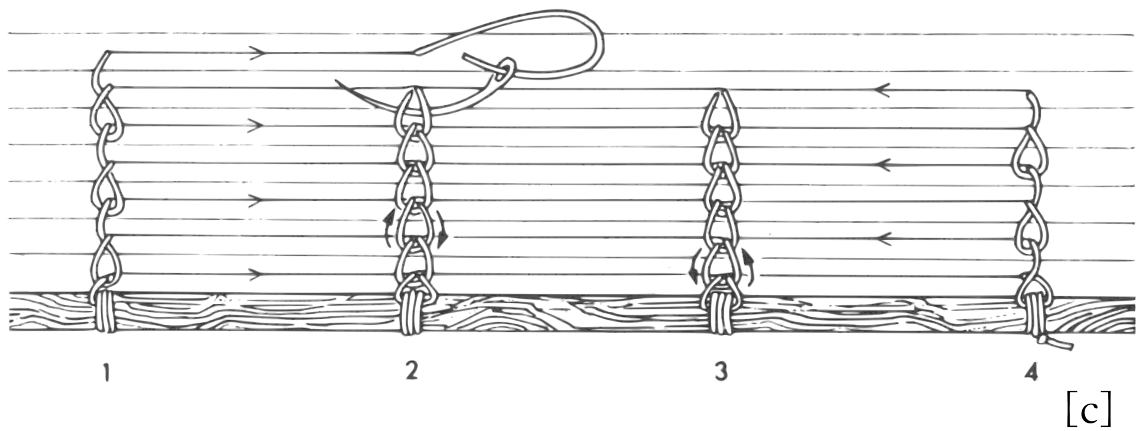
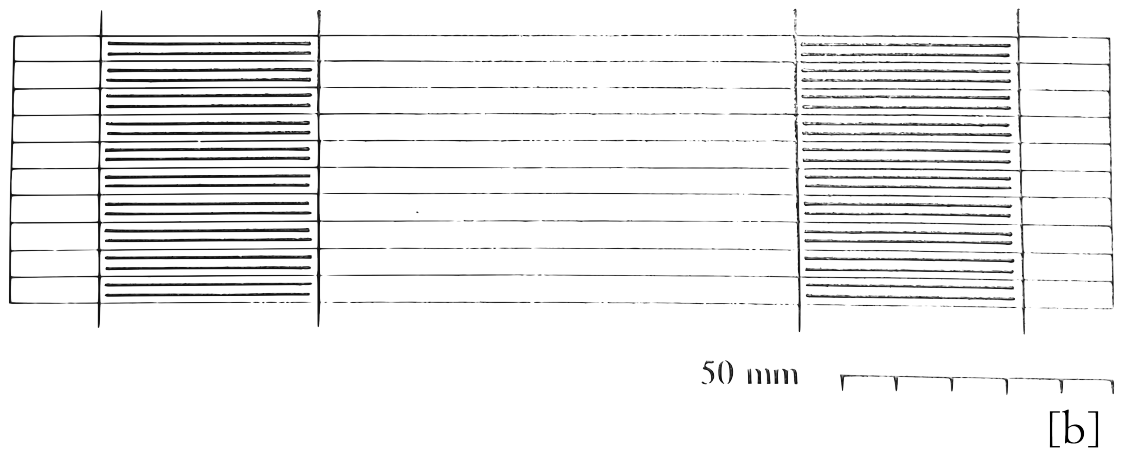

Figure 100. Examples of sewing diagrams in the literature ([a] Szirmai 1999, fig. 3.2, p. 34; [b] Szirmai 1999, fig. 2.3[d], p. 21 — note the visualization of the distribution of the sewing thread lengths within the gatherings; [c] Szirmai 1996, fig. 1[c], p. 147; [d] Szirmai 1999, fig. 9.8[c], p. 188).

# 1671/1083 $\beta$ - sewing

(MEASUREMENTS IN MM)

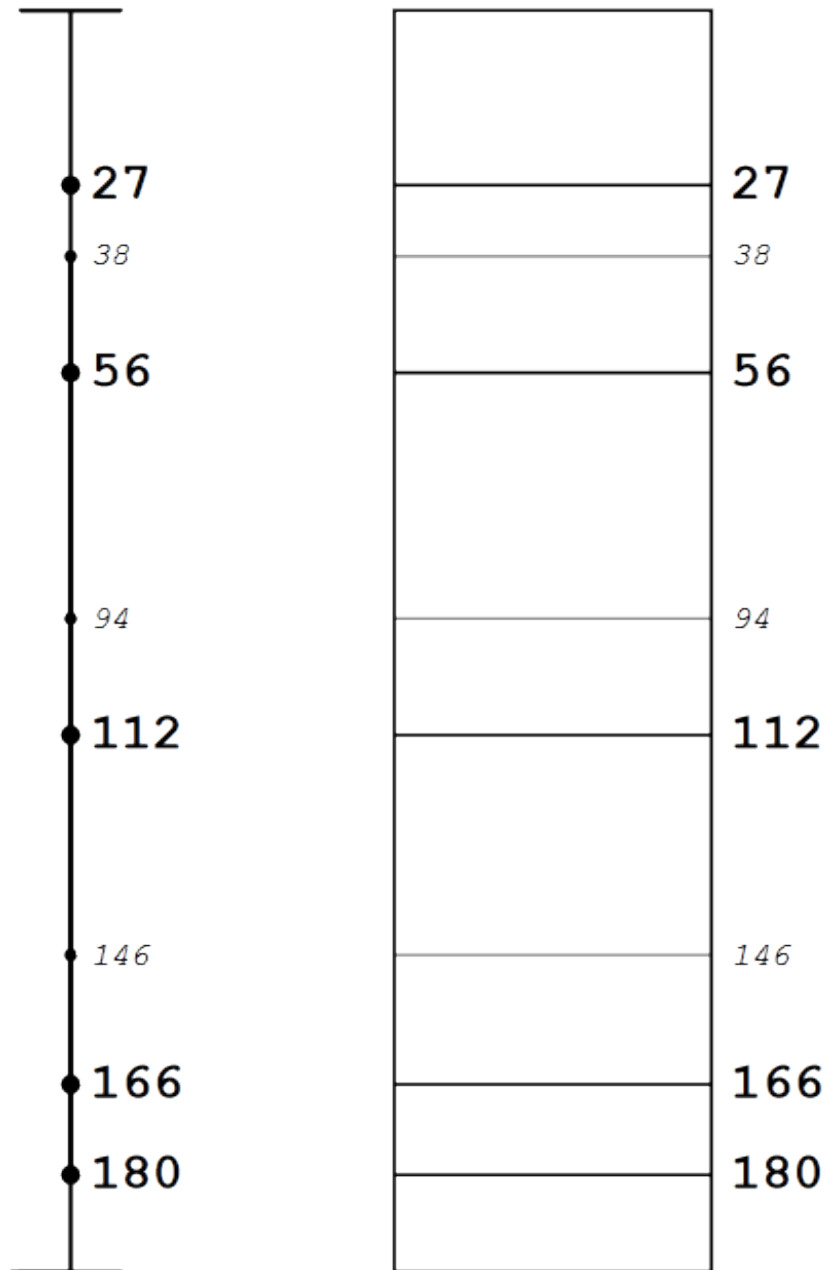

Figure 101. Example of sewing measurement diagram for Vol. 1671/1083 $\beta$ . Note the visualization of both *current* and *previous* sewing stations.

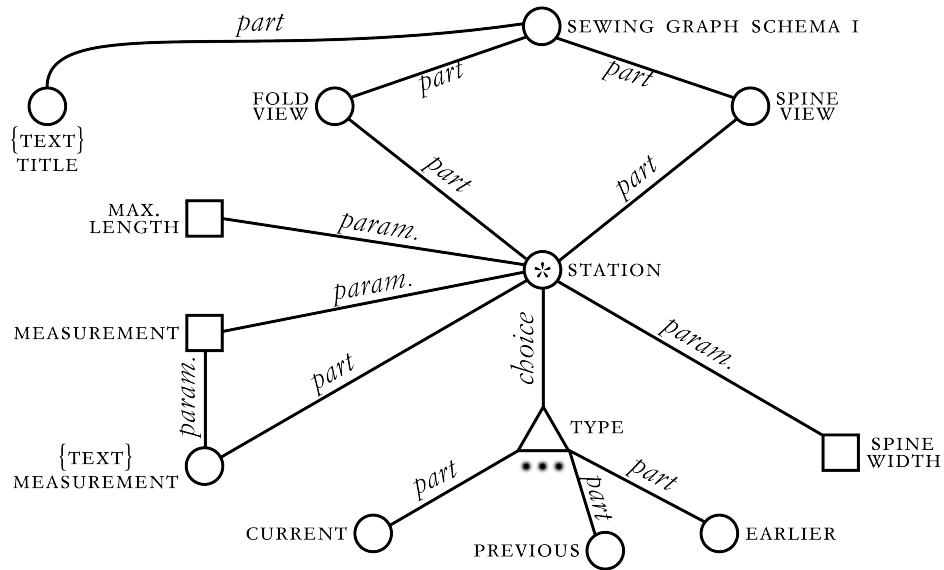

Figure 102. Graph schema for sewing measurement diagrams.

belonging to the two other groups (previous and earlier sewings) one can generally only mention the position on the fold and the kind of holes observed.

In the literature there are three main kinds of sewing structure visualizations: (i) simple diagrams only showing the position of the sewing stations, usually with their measurement (see Figure 100[a] and [b]); (ii) detailed diagrams showing the development of the sewing thread along the gatherings, around the sewing supports (when present), and from gathering to gathering (see Figure 100[c]); (iii) cross-section diagrams showing the path of the thread for a single gathering (see Figure 100[d]). Each kind of visualization has its purpose and is useful for different reasons. Simple diagrams like (i) for example can show the distribution of sewing stations along the spine of books and make it easier to compare similar distributions among different volumes, more than merely through numeric values of the measurements, as their relative position is more useful to identify patterns than absolute values. Examples (ii) and (iii) instead, are able to present the path of the thread, thus allowing for easier analysis and comparison between different sewing structures. As seen in Figure 100[a] and [b], the simpler diagrams with just the position of the sewing stations and their measurements can either show the sewing station distribution along one ideal gathering or on the full thickness of the volume. The two visualizations are similar in their scope, however, showing

the full thickness of the volume adds extra information on the appearance of the sewing pattern for the whole book.

The diagrams here reflect these visualization conventions. There are two different kinds of diagrams: one only takes the measurements of the sewing stations and plots them on the diagrams of the spine of the book and fold of a gathering (see Figure 101); the other visualizes the path of the sewing thread as it develops across a gathering and through the spine (see Figure 104).

Simpler diagrams showing the position of the sewing stations set against the full thickness of the volume indicate the distribution of the sewing thread lengths within the gatherings (see Figure 100[b]), and this is a rather important feature to visualize bypass sewing structures for example. However, the information contained in the schema at the time of the survey did not allow for such detailed visualizations, and bypass sewing structures are thus not visualizable. For similar reasons, the sketchy information regarding stitched and longstitch sewing structures leads to too many assumptions for a visualization to be possible at this stage of development of the schema.

In the latter kind of diagrams, for those cases in which it is possible to visualize the sewing thread, sewing direction arrows denote the conventional sewing direction depicted in the diagram. The direction of sewing — from the first to the last gathering, or the reverse — provides important clues on the spatio-temporal origin of the book. The sewing direction can be determined examining the sequence of chainstitches or kettlestitches, when these are clearly visible. However this information is not recorded in the St. Catherine's schema. In the diagrams the sewing is drawn as going from the bottom gathering to the top (or meeting in the middle) as a standard option, which represents the common sewing direction from the first gathering to the last, with the head of the volume placed towards the left. Change-over station groups instead symbolically represent the passage of the thread from one gathering to the other. These are blurred areas connecting the thread paths in each gathering at the change-over station and take a verbal label to explain their meaning. The verbal label is necessary because of the arbitrariness and novelty of the convention. There are no similar conventions in the literature, but this was deemed necessary to avoid drawing an otherwise naturalistic but

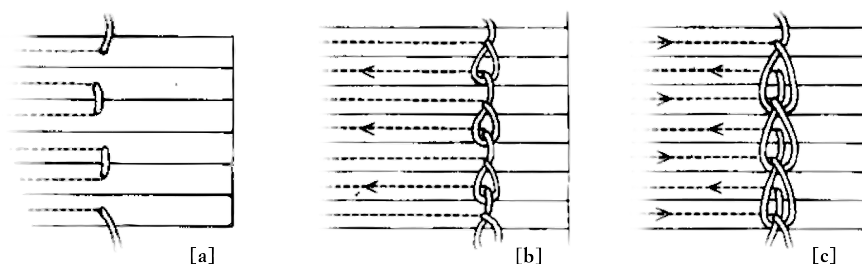

Figure 103. Examples of change-over stations ([a] Szirmai 1999, fig. 7.16[b], p. 116; [b-c] Szirmai 1999, fig.2.1[e-f], p. 17).

random shape. This decision was twofold: firstly it is usually very difficult to be able to determine the exact nature of the type of thread-link connecting the gatherings together without taking the sewing apart (Figure 103 shows different kinds of kettlestitch or change-over thread passages); secondly, in the *Ligatus* schema, because of the difficulty just mentioned, there is no information on the kind of link at the change-over station (apart from the fact that it is unsupported or that it is a kettlestitch).

### 7.2.3. BOARDS

The wood, pasted paper, single- or multiple-ply sheets, or other material, used for the covers of bound books to protect the leaves. Boards are usually used in pairs and they never extend around the spine of the book.<sup>452</sup>

For an accurate visualization, the algorithm requires additional information, such as the shape of the joints in the spine, and checks whether the endband's core attachment was described as *sewn and recessed*, indicating that a board with squares is cut down to the height of the bookblock to form an endband slip recess to sew the endband to the boards. This information is found in the descriptions of other parts of the binding, but are essential for an accurate visualization of the board.

Each board is visualized in eight different views (head, tail, fore-edge, spine, inner surface, outer surface, and horizontal and vertical cross-sections) and its

<sup>452</sup>. Roberts & Etherington 1982/1994; *Ligatus* 2013.

# 452.221α - sewing

Current sewing (type: allAlong)

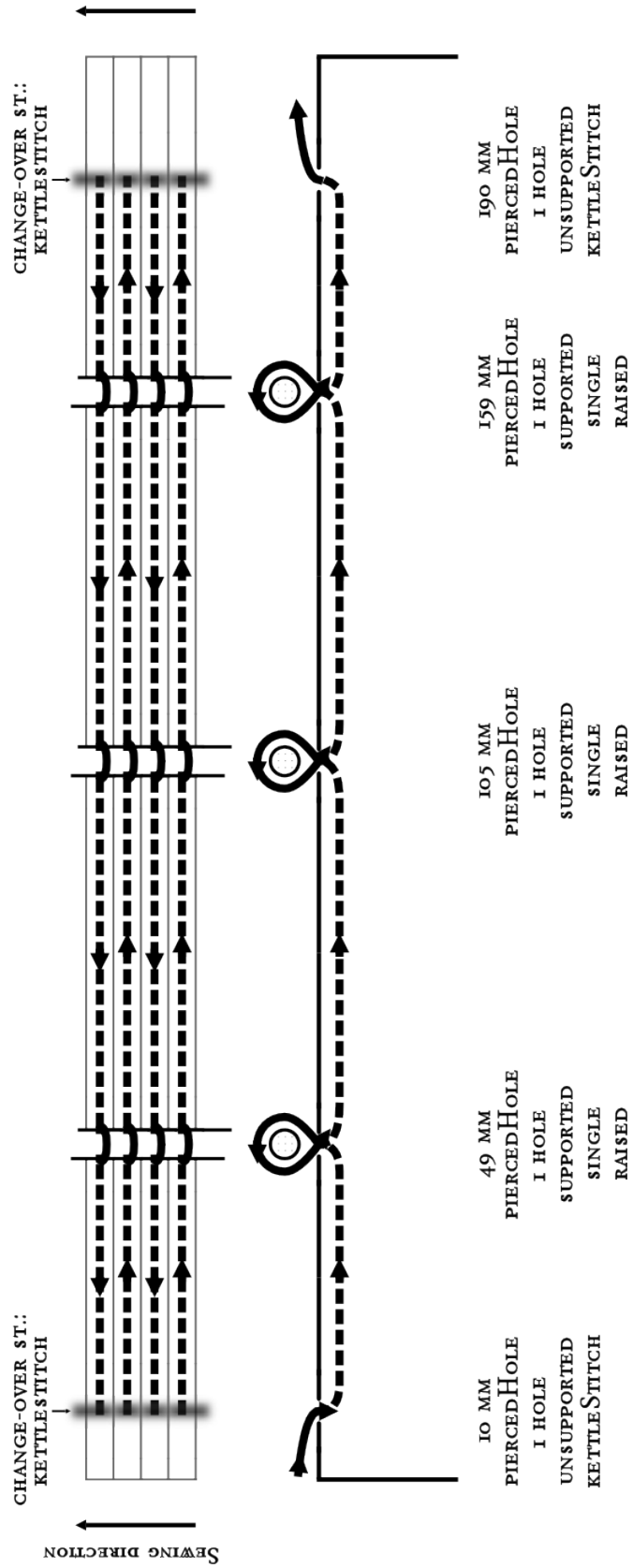

Figure 104. Example of sewing measurement diagram for Vol. 452.221α.

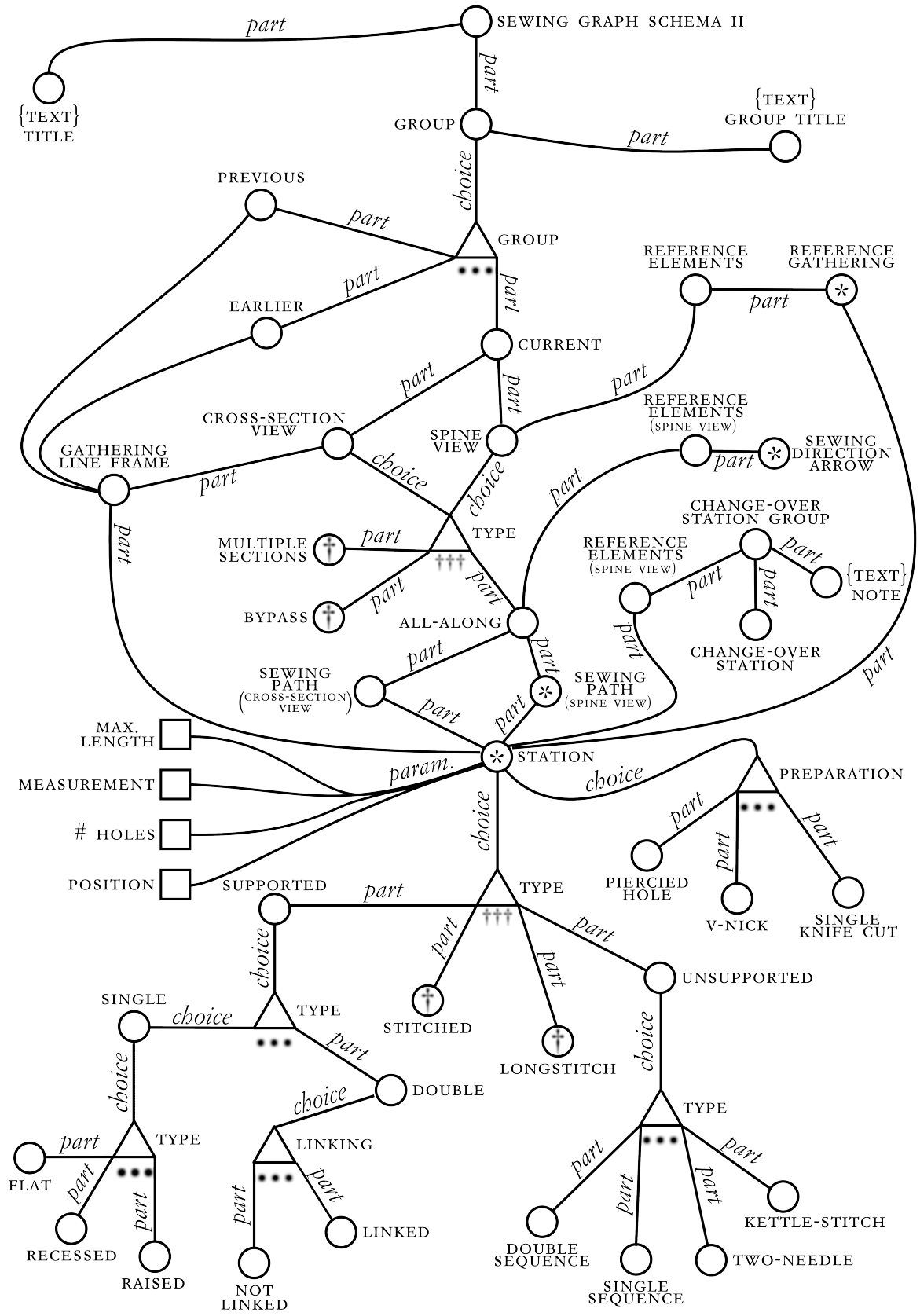

Figure 105. Graph schema for sewing measurement diagrams.

shape is formed by a series of continuous lines, each defined by six different parameters (edge treatment type, bevel type, fore-edge and spine corner type, joint shape, and endband recess). These parameters dictate the shape of a specific part of the board. The line drawing for each of these board features depends on the shape of those contiguous to it. The one-to-one relationship between description and graphic nodes is preserved, but the overall visual effect is that of one continuous shape onto which specific graphic sememes can be read in different areas of diverse magnitude. Back-cornering,<sup>453</sup> for example, is indicated in the spine view as a single line across the thickness of the board, whereas, bevels can extend across the whole height of the board in fore-edge views. This is where, as mentioned in the literature and as described in the previous chapters, verbal and visual languages differ substantially. This is also one of the facts that make automated intersemiotic translations a challenging process that may be automated, but that is not simply a matter of mechanically matching verbal labels with graphics and placing them on the plane.

#### 7.2.4. SPINE SHAPE AND LINING

The schema describes the shape of the spine of the bookblock in an approximate and categorized manner distinguishing between its degree of roundness (flat, slight round, round, heavy round) or the shape of its joints (flat, slight, quadrant, angled, square, acute). This allows inputting a record of the shape of the spine in the database, and to then be able, for example, to search for different values of roundness for bookblock spines.<sup>454</sup>

The spine lining is composed of one or a series of pieces of sheet material placed on the spine of the assembled bookblock as reinforcement, and either adhered to it or held in place without adhesive.<sup>455</sup> There can be more than one lining, and

---

<sup>453</sup>. Back-cornering: the process of cutting away a small piece of the spine edge of a board at head and tail to relieve the strain on the joints of the book when the covers are opened (Roberts & Etherington 1982/1994).

<sup>454</sup>. Ligatus 2013.

<sup>455</sup>. Roberts & Etherington 1982/1994; Ligatus 2013.



# 4689.3137 - left board

Edge treatment: type3  
 Bevels: internalBevels  
 Corners: type5 (foredge), NK (spine)  
 Joint shape: angled  
 Endband recess: yes

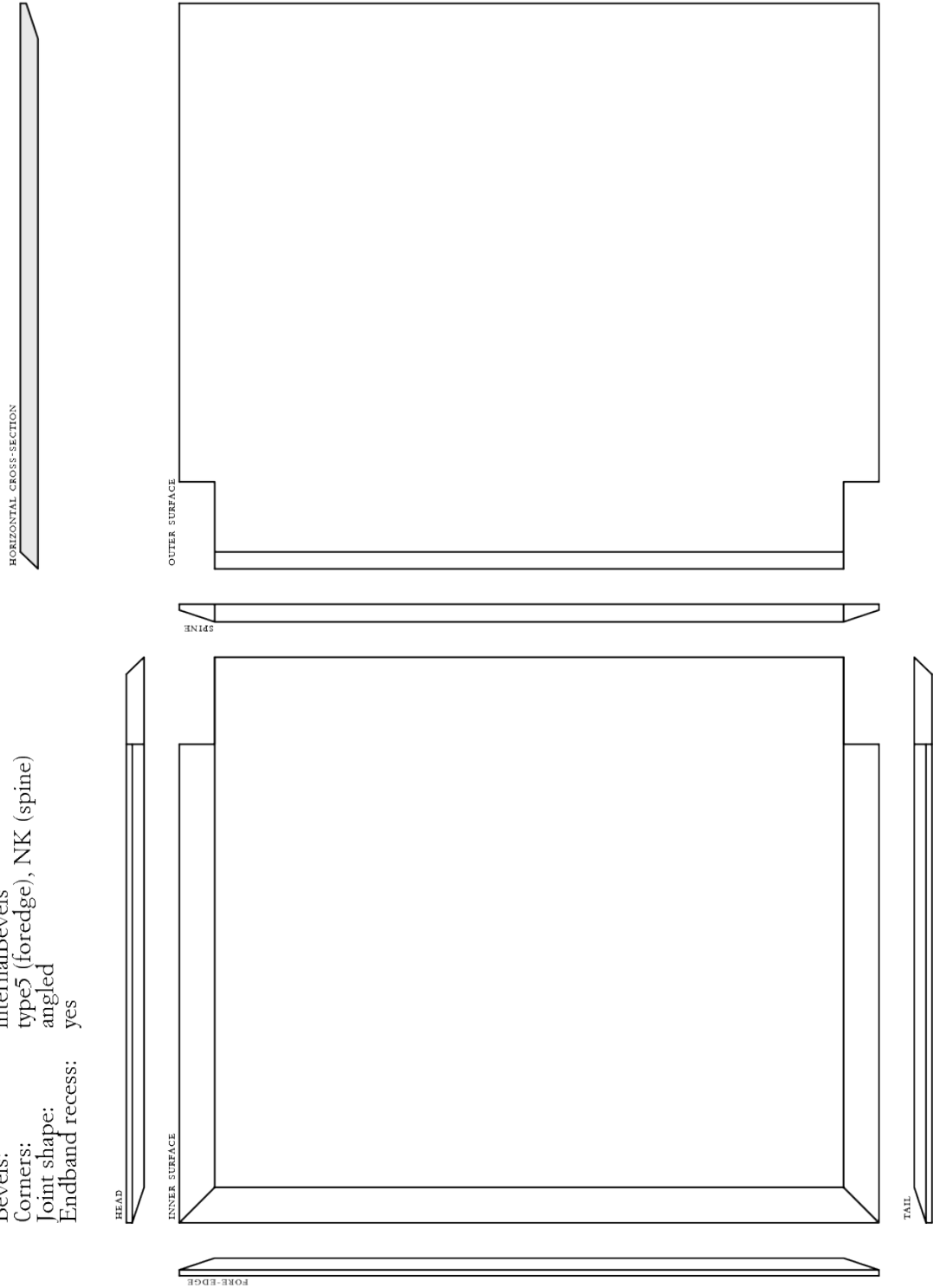

Figure 106. Example of board diagram for Vol. 4689.3137 (left board).

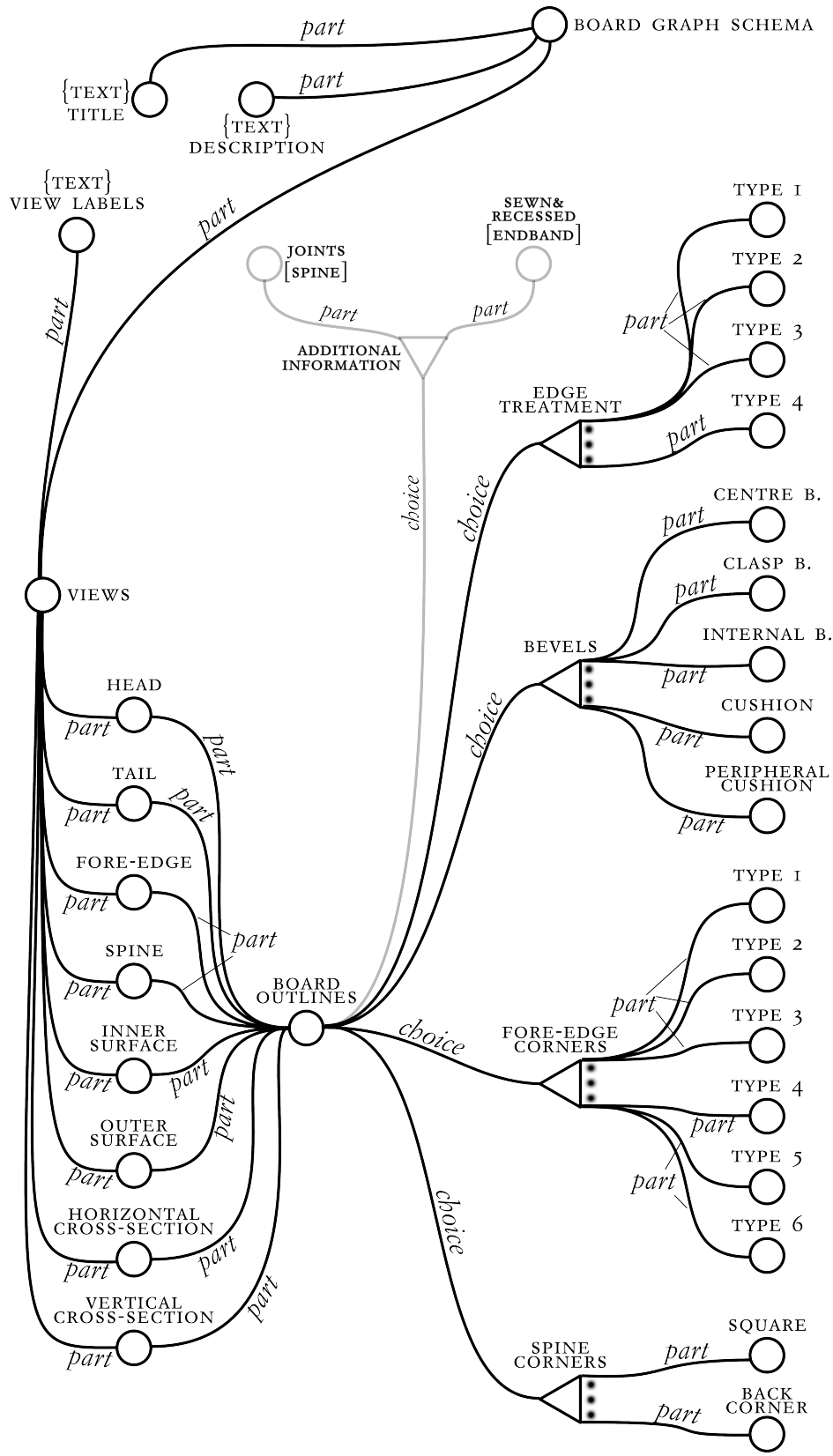

Figure 107. Graph schema for board diagrams.

### 10.3ε - spine profile

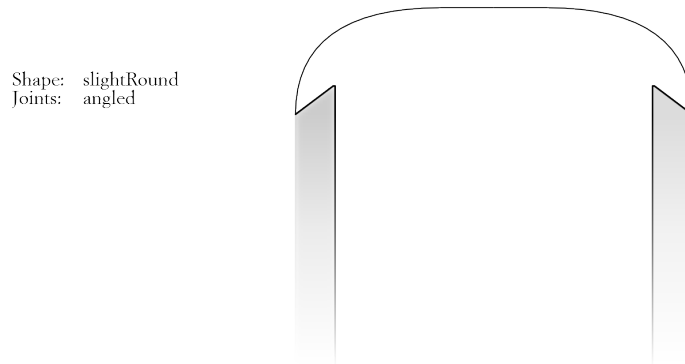

Figure 108. Example of spine shape diagram for Vol. 10.3ε.

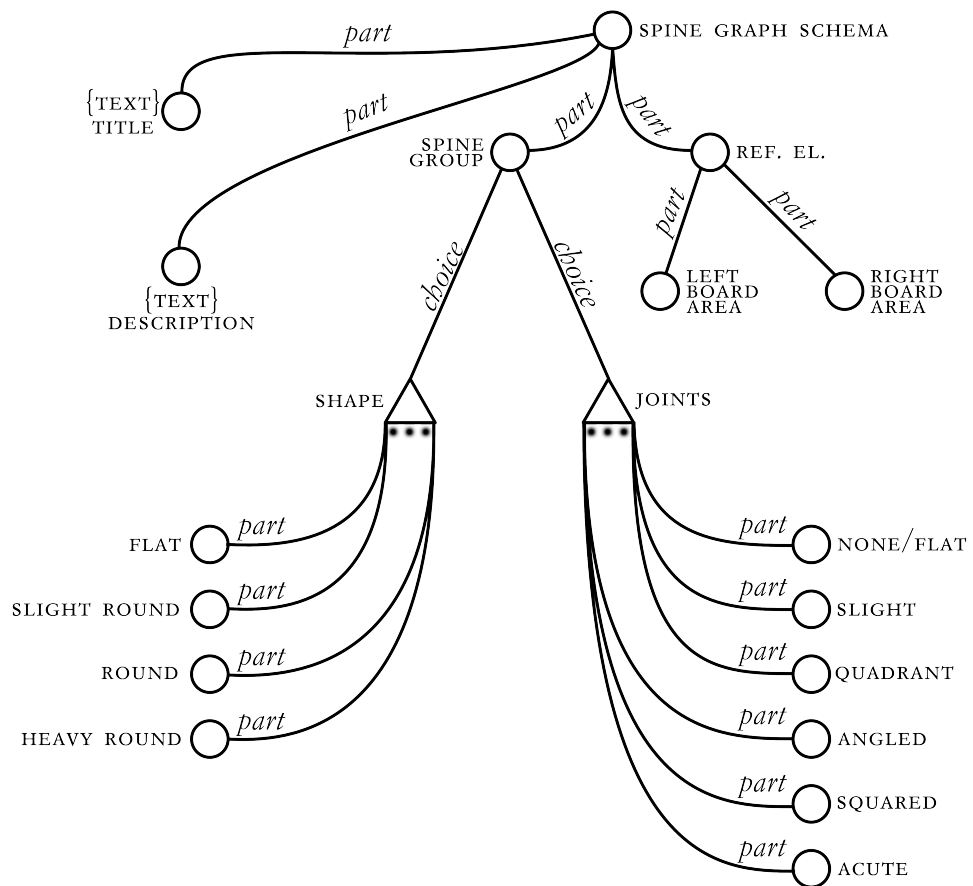

Figure 109. Graph schema for spine shape diagrams.

# 184.97α - spine lining

# linings: 1  
Type: transverse  
Location: selected  
Lining joints: insideBoards

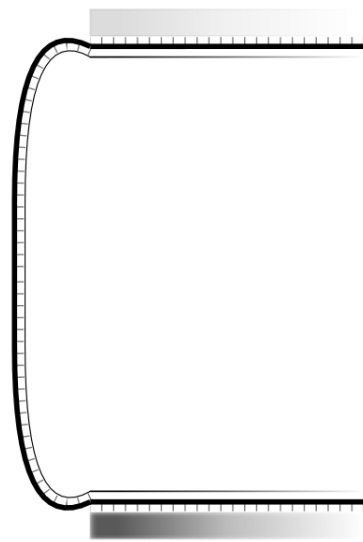
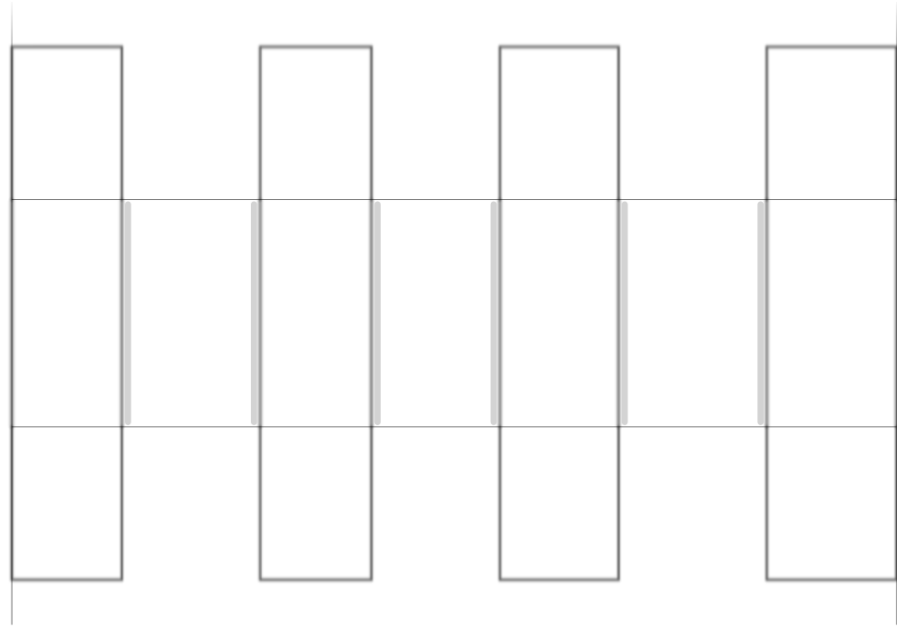

Figure 110. Example of spine lining diagram for Vol. 184.97α.

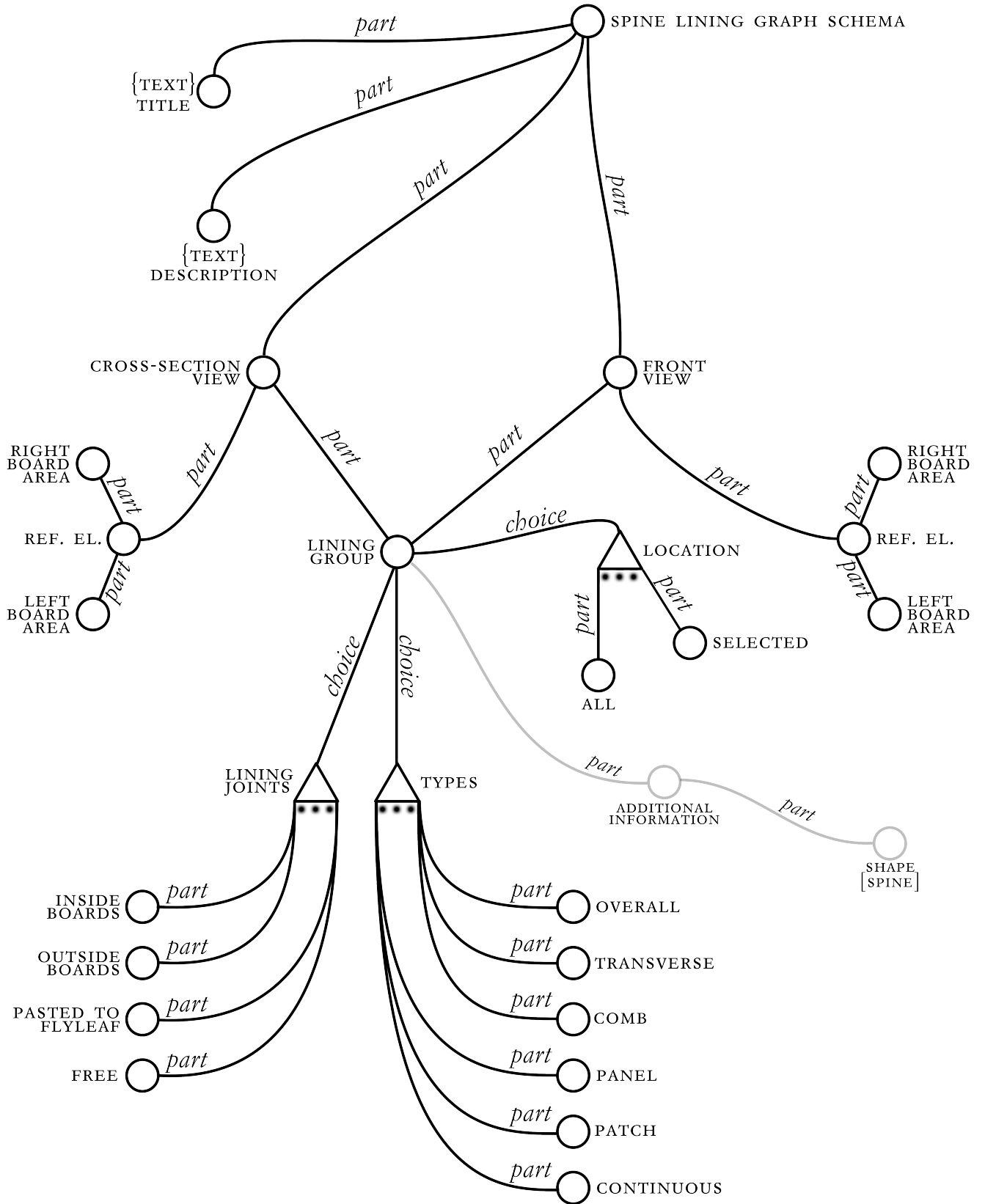

Figure 111. Graph schema for spine lining diagrams.

these can be of different types. A common example is that of the combination of *transverse* and *panel* linings: these would be described as two different linings at *selected* location in the schema. However, the location description is only indicative (the choices are *all* or *selected*) without a precise indication of which panels<sup>456</sup> are covered by which lining. In this case the form of the structure is not preserved in the description as the schema fails to capture in its structure the logical form of the specific lining arrangement. As a result a visualization based of this schema will inevitably be inaccurate when different types of lining are combined. Usually, in the schema structure, a series of successive elements indicates and is interpreted as a spatial succession of those elements — i.e. different layers of spine lining, in this case. However, in such combined linings, the described elements happen to be at the same level, but in different positions, thus forming together one sole composed layer. This problem would not have occurred, if the location of the lining had been described in more absolute terms — i.e. panels 1 and 5 — or, less ideally, if a complex type *transverse & panel* had been introduced, defined for example as spine linings composed of transverse linings at head and tail and panel lining for the rest of the panels (a common feature). As it stands, there is no practical or immediate solution to this problem, apart from highlighting uncertainty or opting for one separate visualization for each spine lining, while still highlighting uncertainty. Because this combined transverse and panel lining was only recorded once in the dataset (Vol. 2609/1886) and because the problem was due to a schema limitation, the former solution was chosen, but further work would need to be done on both the algorithm and the description schema for a future application.

Like in the case of board diagrams, both spine shape and spine lining diagrams (especially in cross-section view) are formed by a series of continuous lines defined by a number of parameters. The formation of each portion of the line is informed by a parameter, but depends in its final shape on the overall shape of the complete line. In these visualizations, the parametric line generation algorithm is rendered

---

<sup>456</sup>. The term *panel* indicates the area between two sewing supports or between the head of the spine and the top and bottom supports (Ligatus 2013).

more complicated by the presence of curved lines that need to be modified case by case preserving their integrity.

### 7.2.5. ENDBANDS

Endbands are cores sewn or pasted across the head and tail of a bookblock spine. When sewn (see Figure 112), these are attached to the bookblock by a primary sewing through the fold of the gatherings which loops around the core. When pasted (stuck-on endbands, see Figure 114), these are essentially transverse spine lining attached to the head and tail panels.<sup>457</sup>

Endbands are rather complex structures, but they can be described in their essence through a series of typological parameters. The schema describes sewn endbands according to the number and type of cores involved, the core attachment type, the sewing type, and the class of number of tiedowns (*in every gathering, frequent, or infrequent*). The drawback of this description-by-categories approach is that it does not allow the description of unusual endbands. On the other hand, the use of categorical descriptions permits to implement a highly symbolic visualization system. Chapter 6 discusses the symbolic nature of endband cross-section drawings. The same considerations can be extended to the rest of the views and elements for these visualization. For example, the schema does not indicate the exact number of gatherings in the bookblock,<sup>458</sup> nor does it indicate which gatherings are used for the primary endband sewing. As a consequence, in the diagrams, tiedowns are spaced evenly across the spine, in a variety of densities (*every, frequent, infrequent*). This symbolism communicates the sewing pattern, without necessarily indicating the exact positioning of the tiedowns.

---

<sup>457</sup>. Ligatus 2013.

<sup>458</sup>. As mentioned, it lacks any kind of collation formula or similar bookblock formation description.

## 4282.2966 - endband (head)

Sewing type: greekDoubleCore (tie-downs: every)

Cores: core (1), board attachment: sewn; crowning core (2) sewn with primary

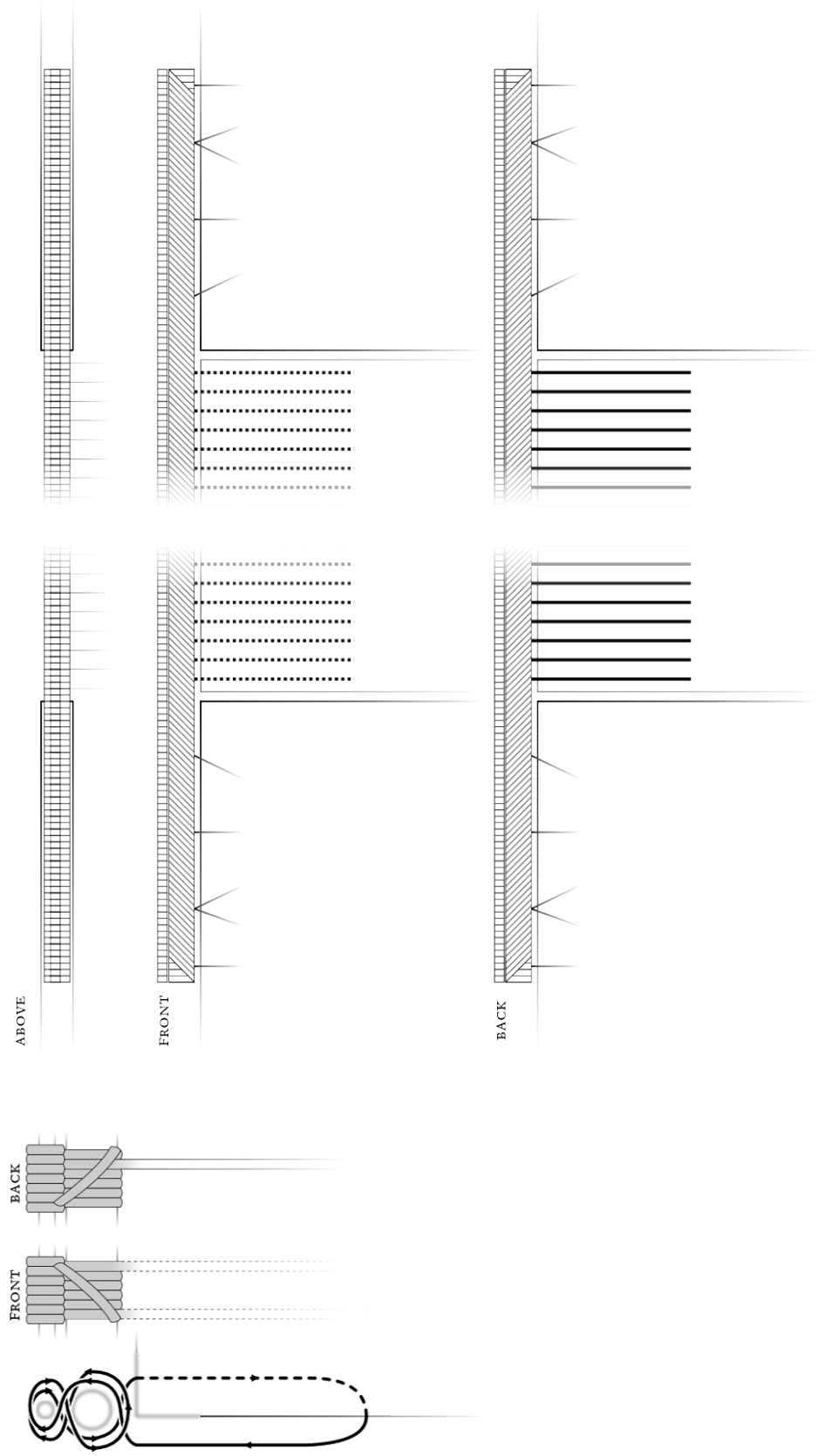

Figure 112. Example of sewn endband diagram for Vol. 4282.2966.



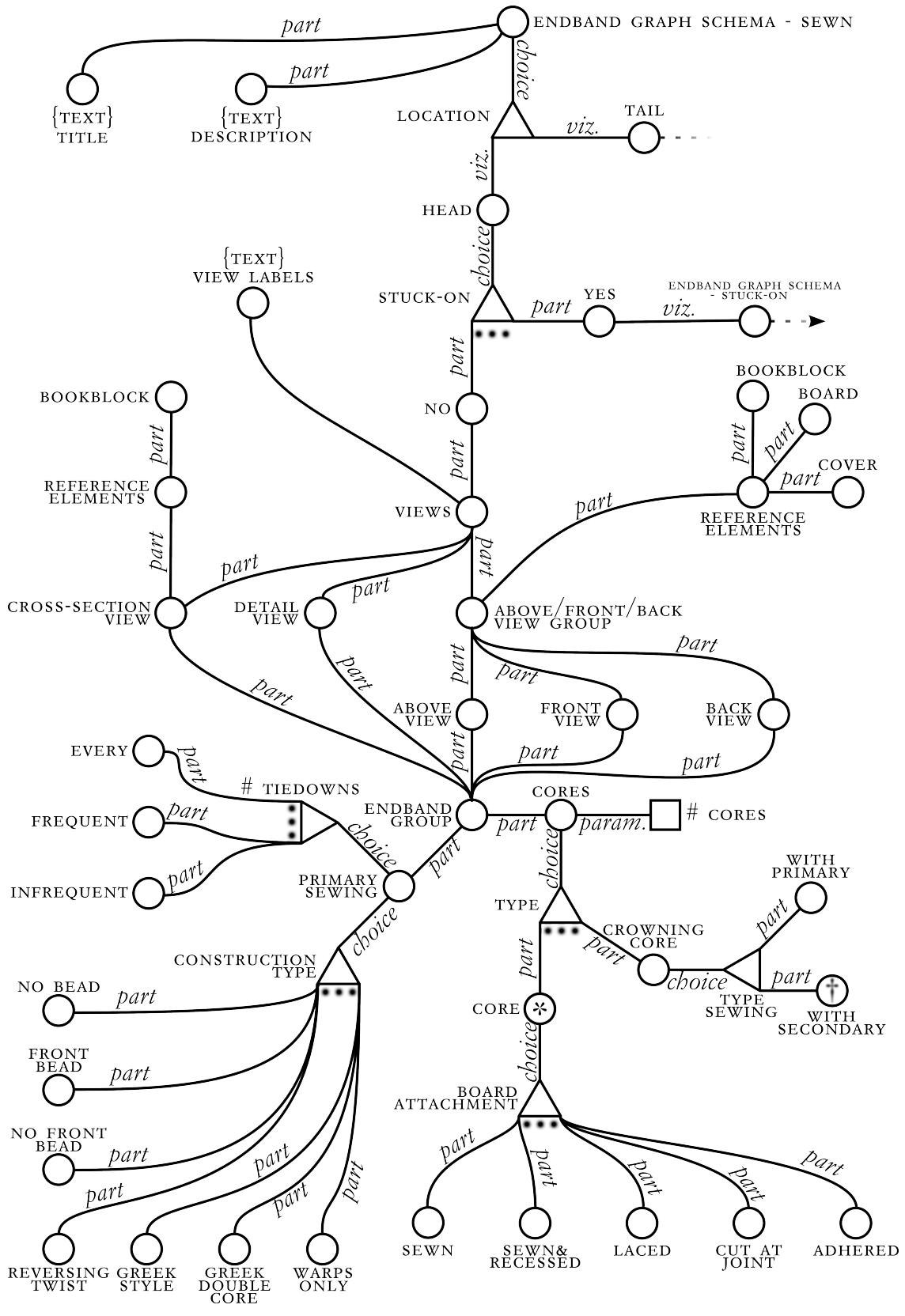

Figure 113. Graph schema for sewn endband diagrams.

## 2236/1539 - endband (head)

Stuck-on:      folded (yes), coverage %: 20%, pasted on boards (yes - outsideBoards)  
Cores:         core (1), board attachment: no

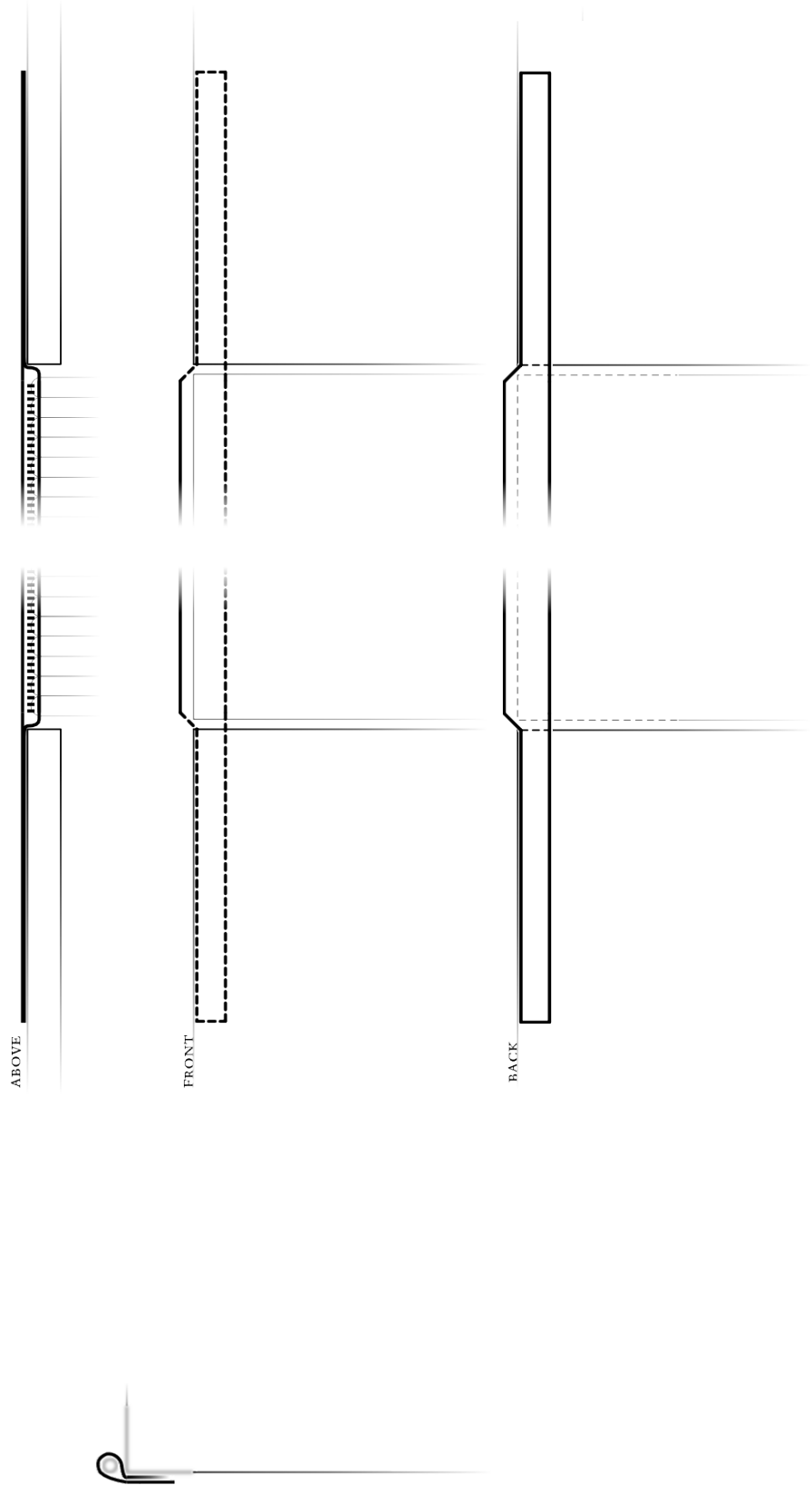

Figure 114. Example of stuck-on endband diagram for Vol. 2236.1539.

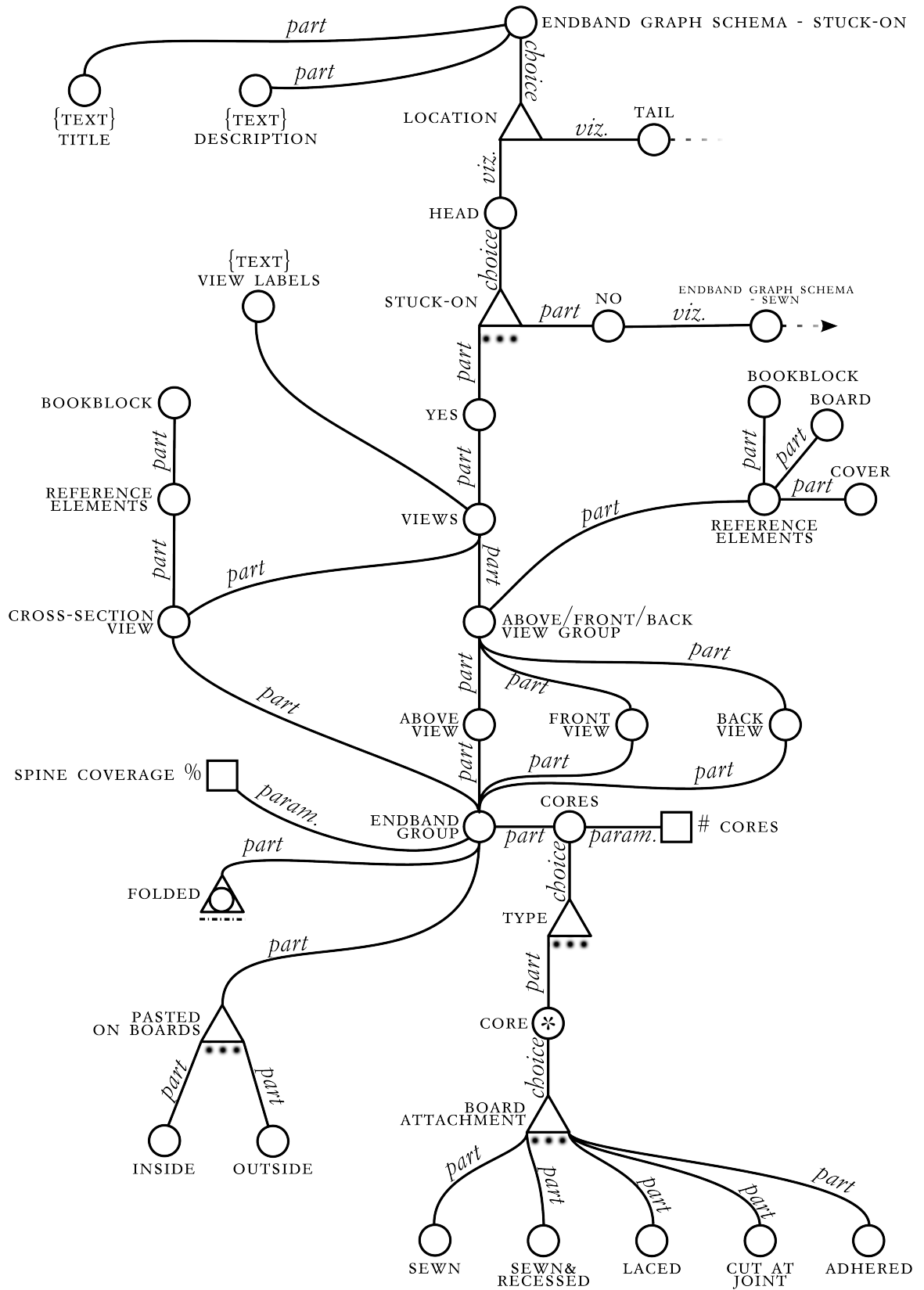

Figure 115. Graph schema for sewn endband diagrams.

## 7.2.6. COVERINGS

The term *covering* indicates those materials put over a book, with the effect of protecting it. The schema distinguishes between four main kinds of coverings (*guard*, *drawn-on*, *case*, and *over-in-boards*) indicating rather different constructions. The two more simple types, *guard* (see Figure 116) and *drawn-on*, are not further specified by other parameters. *Case* and *over-in-boards* covers (see Figures 118 and 120), instead, are further specified by means of a range of typologies and parameters. Because of the diversity in features and the wide range of options, the graph schema is presented here as divided in three related schemas: *guard* and *drawn-on* together, *over-in-board*, and *case* covering respectively (see Figures 117, 119, and 121).

Amongst laced case structures, the schema proposes *laced and tacketed* bindings as a subtype. These are not further described by additional parameters and are defined as follows: ‘case-covers can be attached to a bookblock by both tackets and sewing support slips and/or endband slips.’<sup>459</sup> The definition is generic and does not provide information on an exact typology of structure, describing parts and form. The term used is not at the basic level of abstraction, and, therefore, allows too much indeterminate information. Other structures are only described with a single term and no additional parameters — e.g. cover lining laced cases<sup>460</sup> — but these terms describe an entity at the correct semantic level, thus allowing for it to be visualized.

Once again, these transformations depend on additional information found in the description of other parts of the binding. In particular, the shape of the spine

---

<sup>459</sup>. Ligatus 2007.

<sup>460</sup>. ‘Cover lining: a laced-case cover with a cover lining consists of two pieces of sheet material, one inside the other, which originally were attached to a bookblock one after the other and not at the same time. The cover lining was the first to be attached, and was a piece of sheet material such as cartonnage or laminated sheets of paper cut to the height of the bookblock and endbands, folded around a bookblock and secured to it by lacing the sewing support slips through it. The second part of the cover, usually of parchment was folded round the cover lining, turned-in around its edges and secured by lacing the endband core slips through both parts of the cover at the head and tail of each joint. The result is a binding in which only the endband core slips and not the sewing support slips are visible on the outside of the cover, a fact which can make them externally resemble contemporary Italian limp laced-case bindings in which also only the endband core slips and not the sewing support slips are visible on the outside of the book. The cover lining is distinguished from boards in that both sides are part a single continuous piece of material wrapped around the spine, as opposed to boards which must always be separate entities.’ (Ligatus 2007).

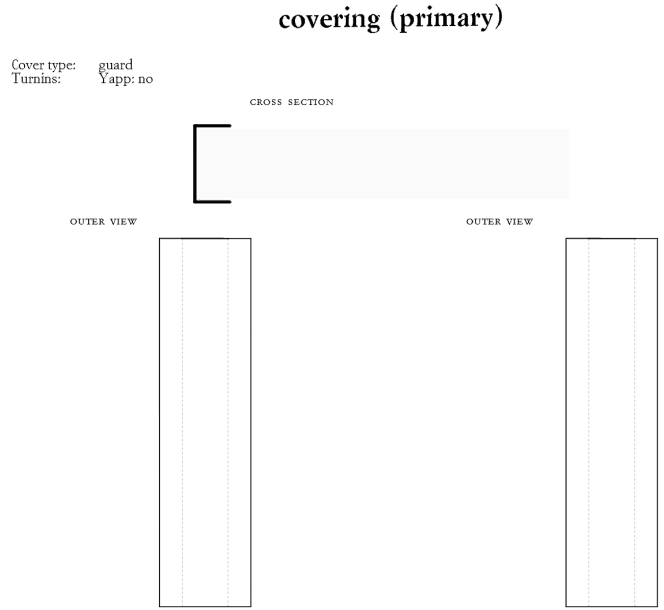

Figure 116. Example of guard covering diagram. No examples of guard or drawn-on coverings were recorded in the dataset.

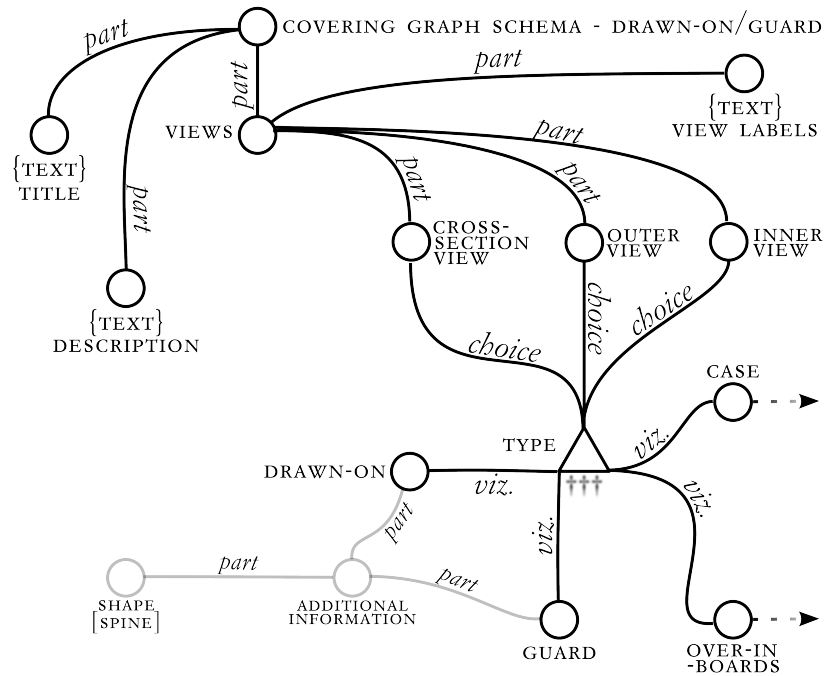

Figure 117. Graph schema for guard or drawn-on covering diagrams.

3148.2285 - covering (primary)

Cover type: overinboard (full)  
Joiner: tight/loose  
Trim: none  
Trimms: foreedge/cfr: rough/Trim: head: rough/Trim: uah: rough/Trim - Yapp: no

TOP DETAIL:  
FOLLOWING VIEW

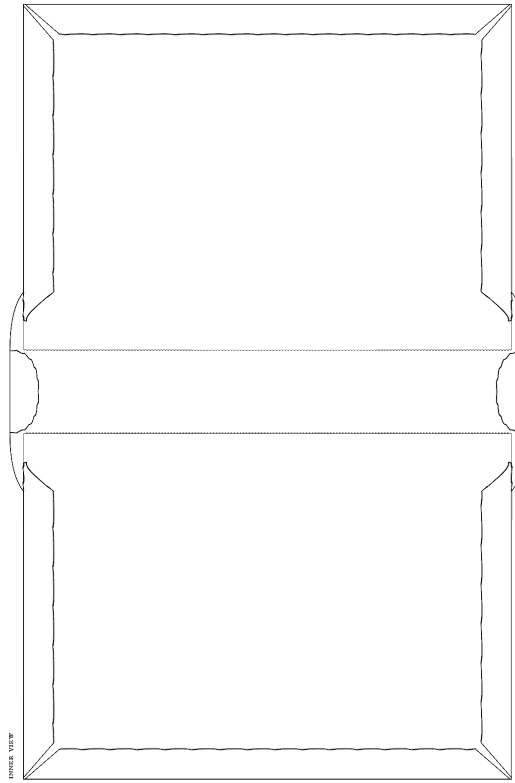
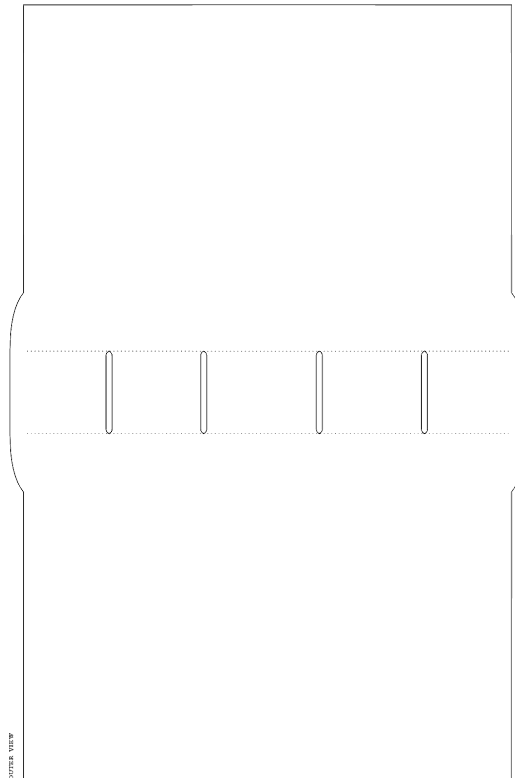

Figure 118. Example of over-in-board covering diagram for Vol. 3148.2285.

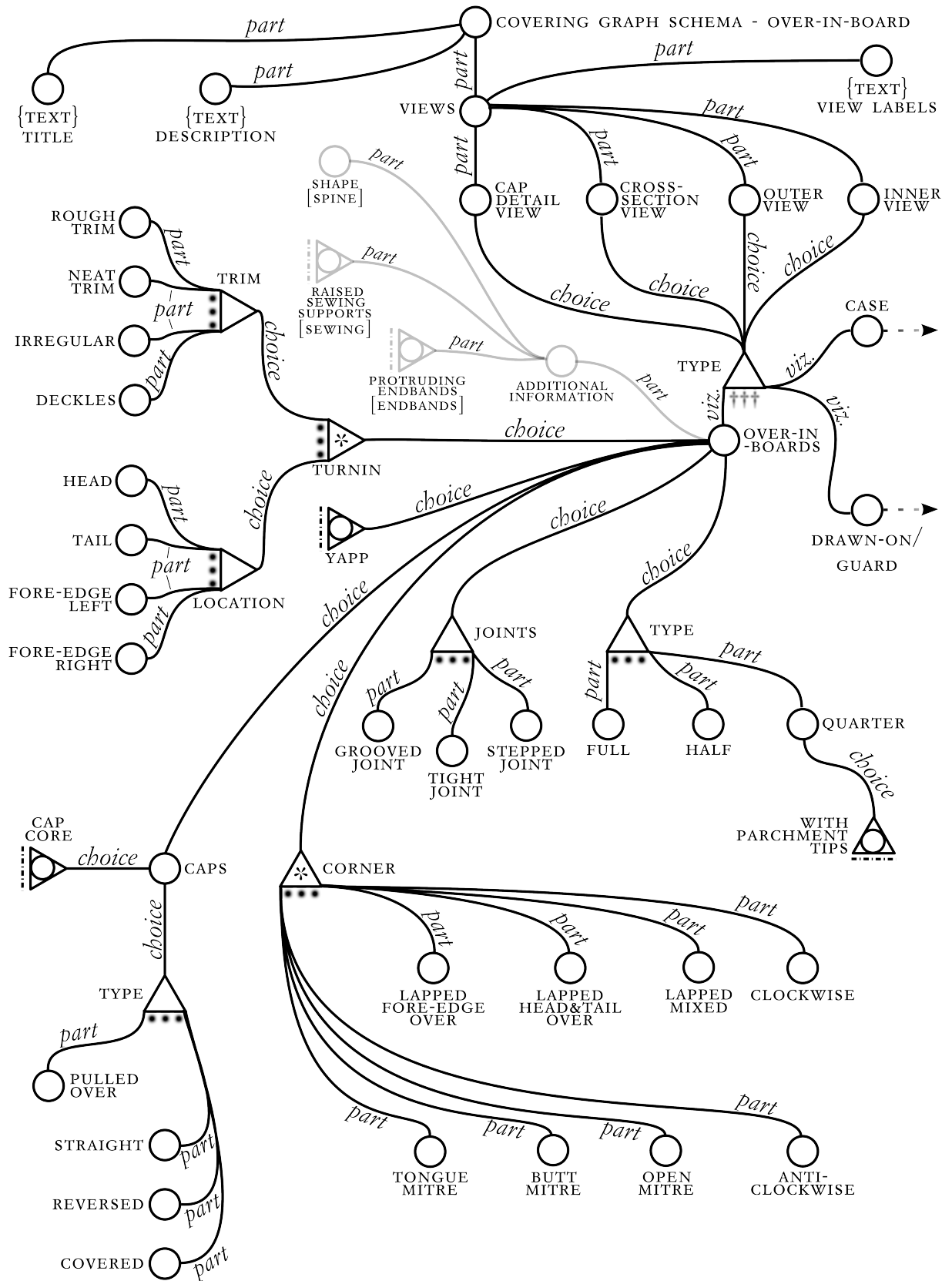

Figure 119. Graph schema for over-in-board covering diagrams.

## 2269.1579 - covering (primary)

Cover type: case (laceAttached: coverLining) - Edges: turnedIn  
 Joins: spine-Crease (joint crease: yes)  
 Corners: lapped  
 Turnins: foredgeLeft: nearTrim; foredgeRight: nearTrim; head: nearTrim; tail: nearTrim - Yapp: no

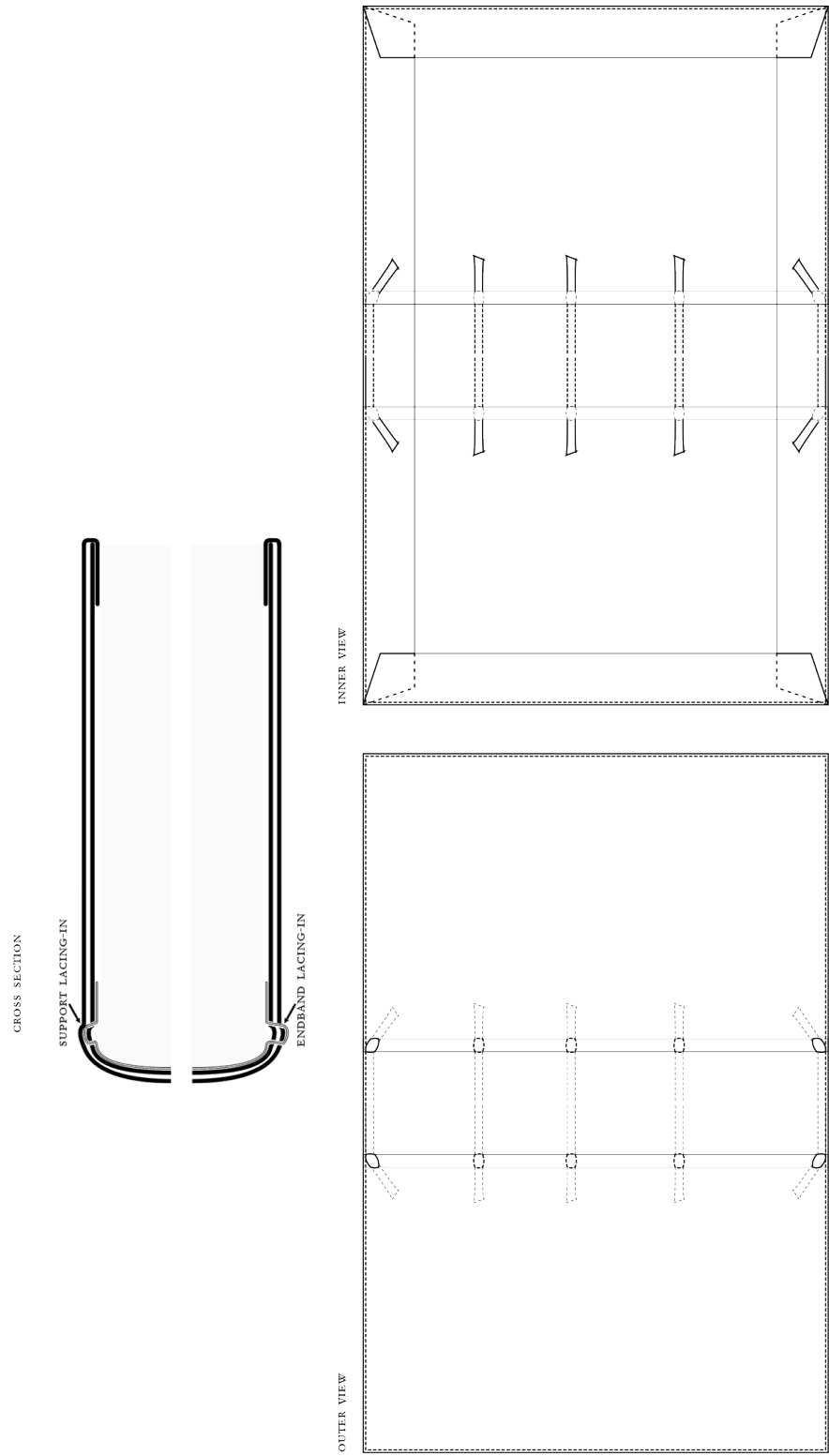

Figure 120. Example of case covering diagram for Vol. 2269.1579.



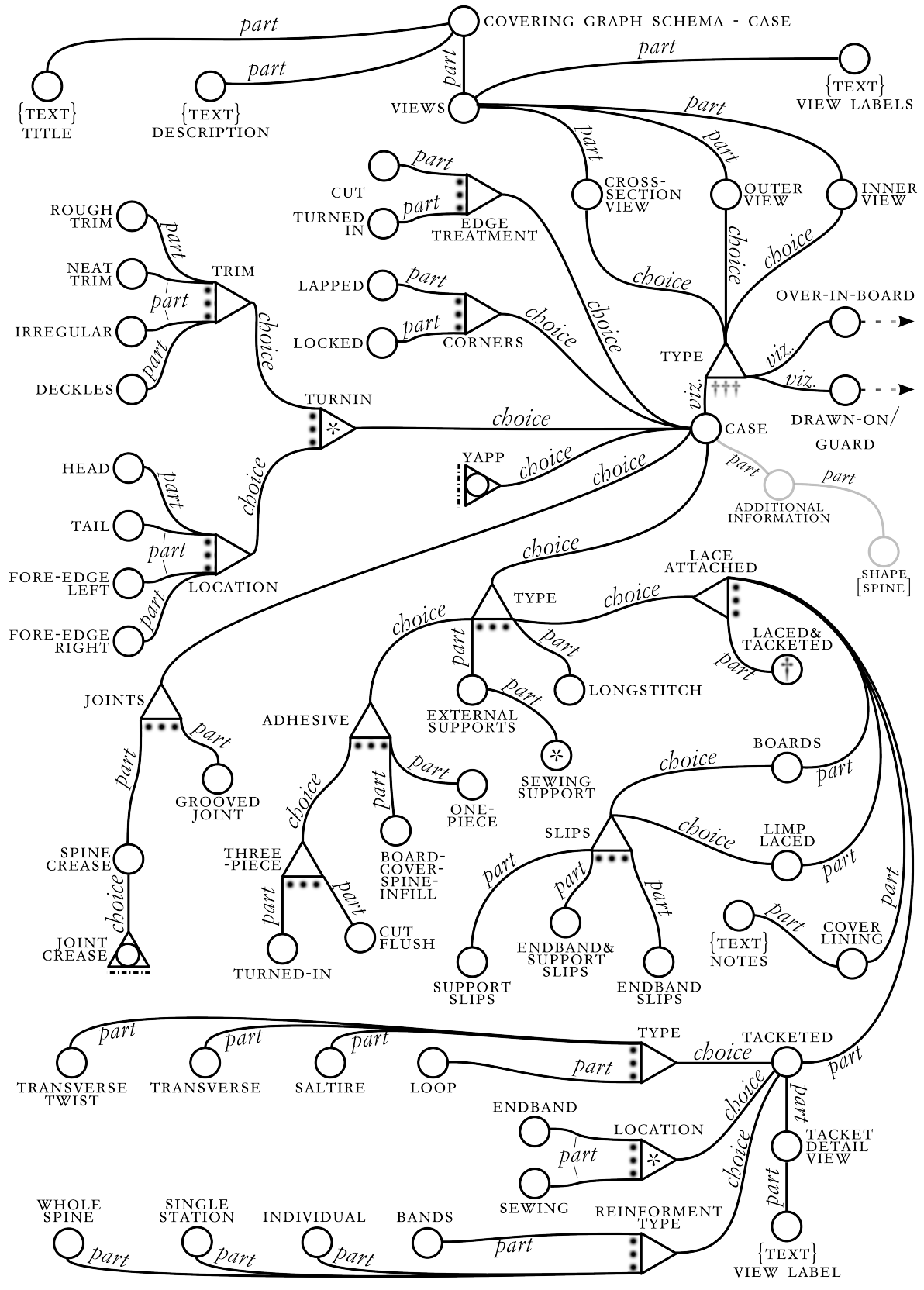
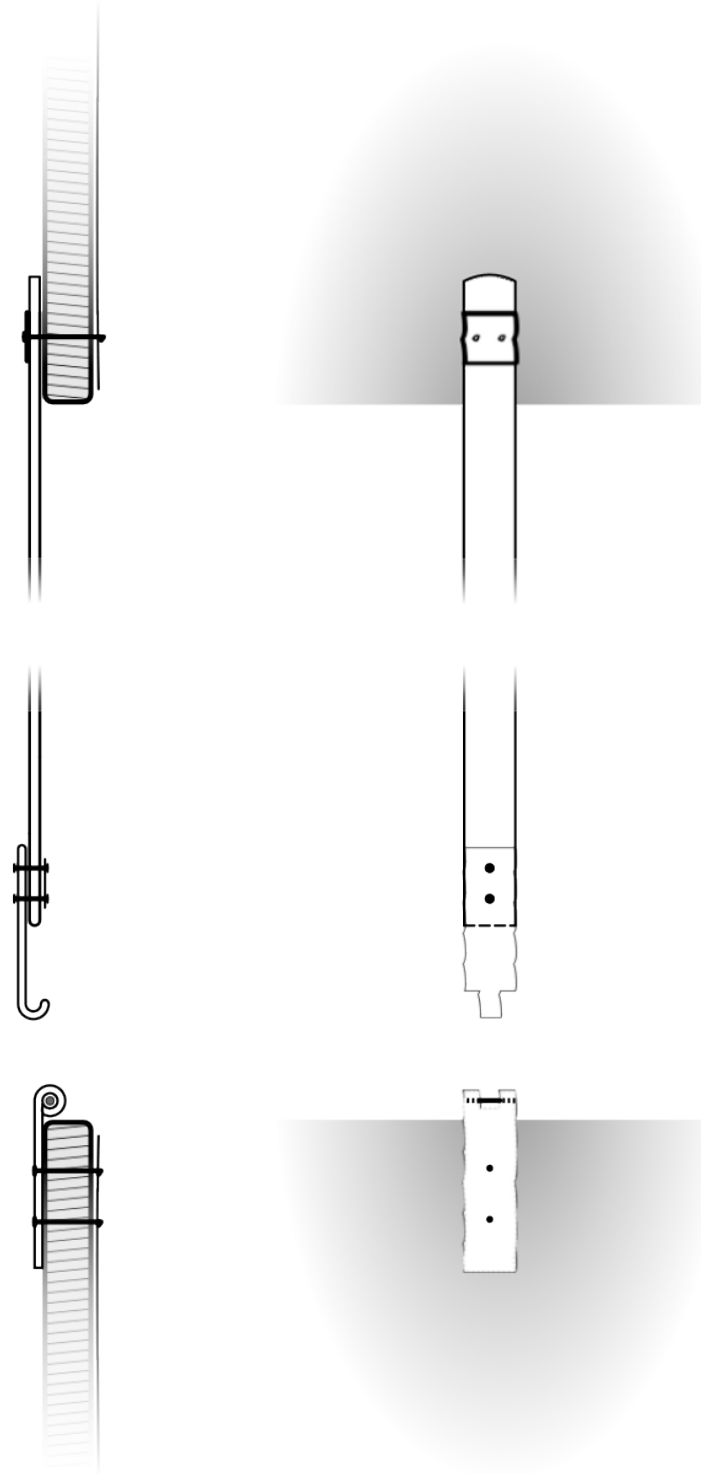

Figure 121. Graph schema for case covering diagrams.

# 3706.2677 - furniture



CATCHPLATE: ROLLERROUND BAR THROUGH PASTEDOWN: YES  
 CLASP: SIMPLE HOOK PASTEDOWN SIDE: UNDER  
 STRAP: FLAT STRAP PLATES THROUGH PASTEDOWN: YES

Figure 122. Example of furniture diagram for Vol. 3706.2677.

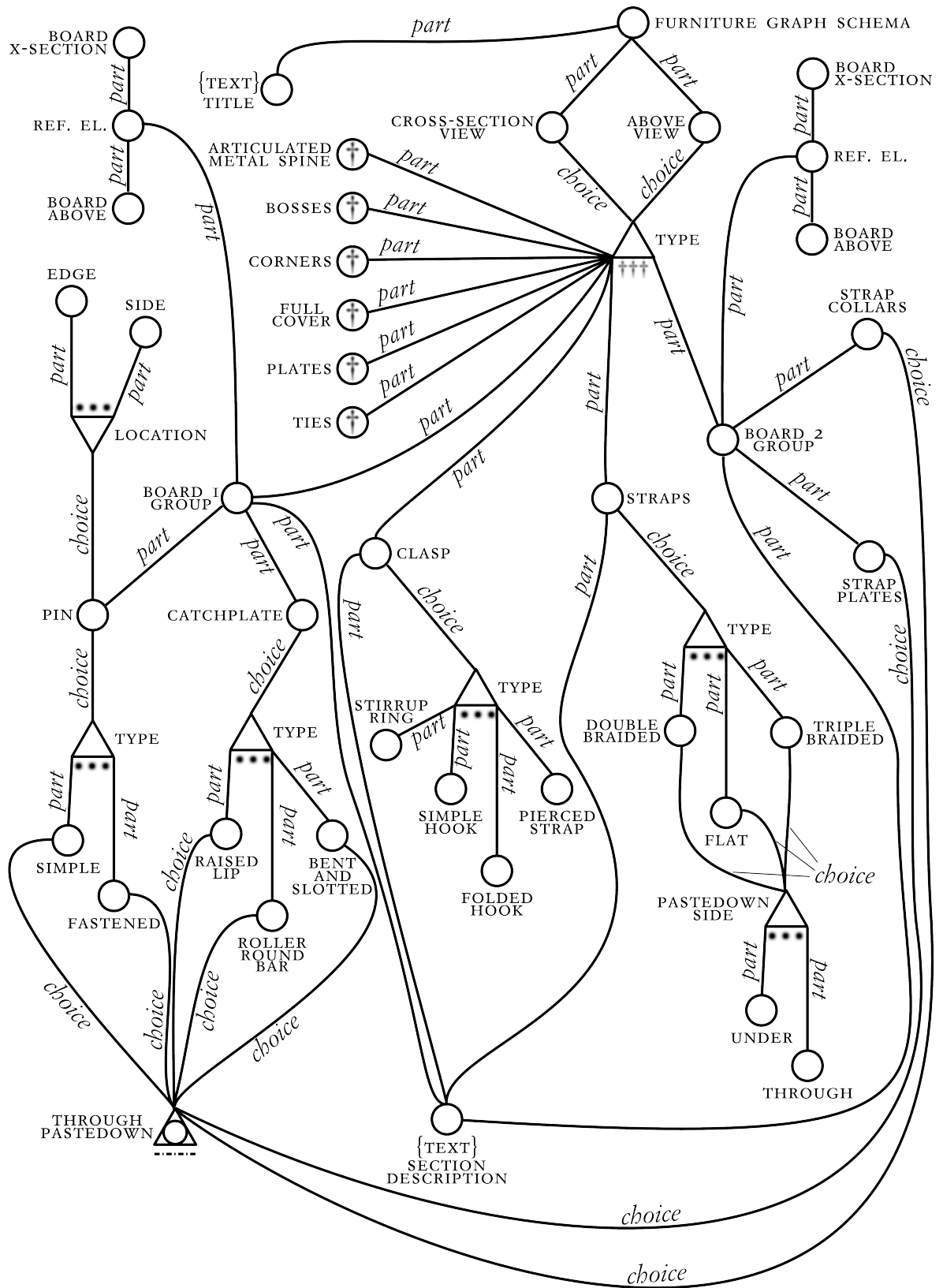

Figure 123. Graph schema for furniture diagrams.

for cross-section views, and the presence of protruding endbands. Also, the final visualization of each of the covering part depends on the shape of adjacent visual sememes. Note in Figure 118 the use of sketchy lines to signal uncertainty in the visualization of turn-in and cap turn-in shapes.

### 7.2.7. FURNITURE

Furniture is the set of hardware that can be attached to a binding, usually with a protective, but also often decorative, function; this includes fastenings used to hold a book shut when not in use.<sup>461</sup> As pointed out in the previous chapter, furniture include: (i) articulated metal spine, (ii) bosses, (iii) corners, (iv) full covers, (v) plates, (vi) ties, (vii) catchplates, (viii) clasps, (ix) pins, (x) straps, (xi) strap collars, (xii) and strap plates. Items *vii* to *xii* can be grouped as fastening parts. These are described in sufficient detail in the schema and their descriptions can be turned into useful visualizations. Items *i* to *vi*, instead, are only named by their generic name — e.g. boss or tie — leaving too much indeterminateness for the generation of meaningful visualizations. Note in Figure 122 the use of sketchy lines to signal uncertainty in the visualization of catchplate, clasp, and strap plate decorative shapes, preserving only their functional shape (compare with Figure 124).

---

<sup>461</sup>. Ligatus 2013.



Figure 124. Fastening photographs of Vol. 3706.2677 taken during the survey in 2007.

### 7.3. Dealing with erroneous data

The resiliency of any system has to take into consideration human reliability and the effects of the human factor on the desired outcome and its accuracy.<sup>462</sup> When inaccuracy is objectively determinable, it can be expressed as error.<sup>463</sup> Errors are indicated by the fact that a planned sequence of activities fails to achieve the intended outcome, without intervention of external factors. Human errors can be broadly classified into three main categories: (i) skill-based errors or lapses linked to attention or selection failures; (ii) ruled-based mistakes, linked to the misapplication of rules; (iii) knowledge-based mistakes, linked to inaccurate or incomplete mental models.<sup>464</sup>

In electronic databases, the encoding schema at the base of their structure allows for immediate monitoring of data correctness and completeness during input.<sup>465</sup> Data validation yields to a reduction in errors and acts as quality control. However,

---

<sup>462</sup>. Rouse & Rouse 1983.

<sup>463</sup>. MacEachren *et al.* 2005.

<sup>464</sup>. Reason 1990.

<sup>465</sup>. Mocean 2007.

not all mistakes can be impeded through careful database design, and those errors that do occur are not easy to identify through automated means.

A schema can be highly prescriptive and as close to perfection as possible, but when implemented in a project and used by different people problems do occur. As shown through a selection of examples above, many mistakes in the dataset for this project are due to misinterpretations of the schema rules, for example problems in item numbering conventions for endleaf structures. In other cases, typologies were not understood and were used inconsistently. See for example the diagram of the spine shape for Vol. 5.2 $\beta$  in Figure 126. In the database its joints are described as *slight*, which leads to an odd looking diagram (see Figure 126[a]) However, by looking at the hand drawing for the spine shape (Figure 125), it becomes apparent that the surveyor did not describe the joints correctly, and that in fact, what it was meant was that the volume had *quadrant* joints. By changing the joint typology and regenerating the diagram the shape coincides with the hand drawing (Figure 126[b]).

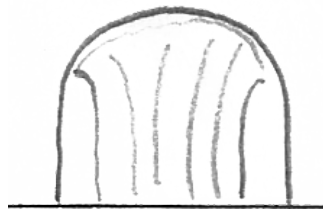

Figure 125. Spine shape hand drawing for Vol. 5.2 $\beta$ .

or

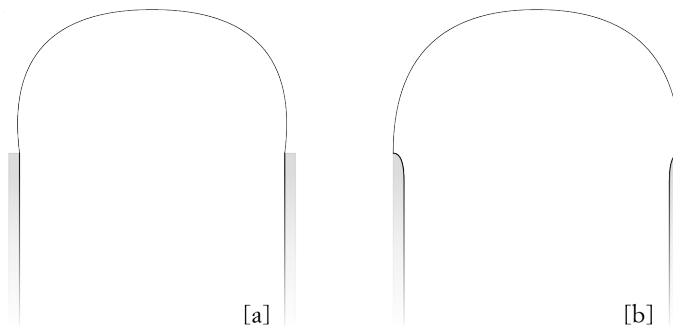

Figure 126. Spine shape diagram for Vol. 5.2 $\beta$ . [a] with *slight* joints; [b] with *quadrant* joints.

It became apparent, during the course of this project, that these types of errors that are difficult to detect automatically could, however, be identified and avoided, if the automated visualisations were to be implemented directly during the survey.

As seen, data can be valid but meaningless. One could foresee the surveyor or a subsequent reader/editor going through the data in the database to check for its correctness, one element at the time, diachronically and in sequence. However, the information describing each binding structure is divided into a series of elements and parameters, which can span multiple description levels. The amount of information needed to be kept in mind to visualise the data and analyse it synchronically is unmanageable as it exceeds the limited capacity of the human working memory.<sup>466</sup> Mistakes, thus, easily slip through the control net and remain unchecked.

During the development of the visualisation algorithms, at times, diagrams would show structures that are not possible in real life. Some of these problems were obviously coding problems in the algorithms that needed to be modified. However, others were the result of something rather different: the coding algorithm was functioning properly showing exactly what had been encoded in the XML binding descriptions, but the dataset contained errors, and these errors were translated into odd looking diagrams.

### 7.3.1. ERROR EXAMPLES

Let us consider some examples of errors found in the dataset. These can be divided into three main groups. As pointed out earlier, (i) there are cases in which the surveyor misinterpreted the description rules and conventions set by the schema, or else, (ii) typologies were not understood and were used inconsistently. In addition to these, (iii) there are obvious slips in which one option in a list was mistakenly chosen instead of the right one. Four examples of errors are reported below; for each example are provided the incorrect and the correct diagram and the hand drawing for the structure carried out during the survey.

---

<sup>466</sup>. Baddeley 2013.

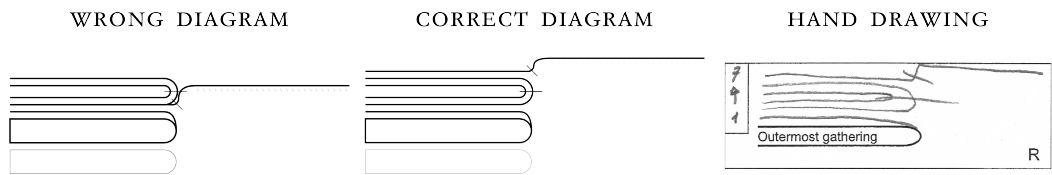

Figure 127. Example 1. Error due to schema convention misinterpretation. Right endleaves for volume 4725.3162.

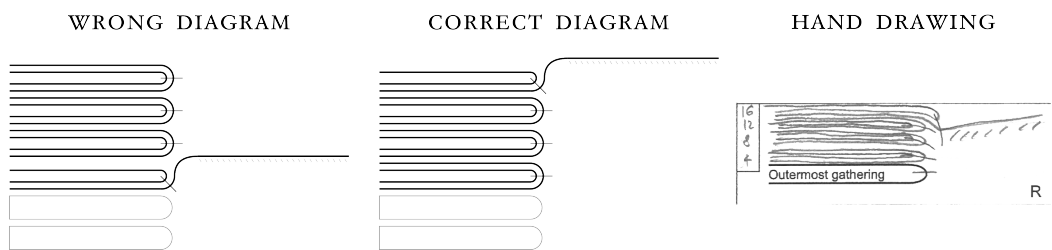

Figure 128. Example 2. Error due to description convention misinterpretation. Right endleaves for volume 5365.3471d.

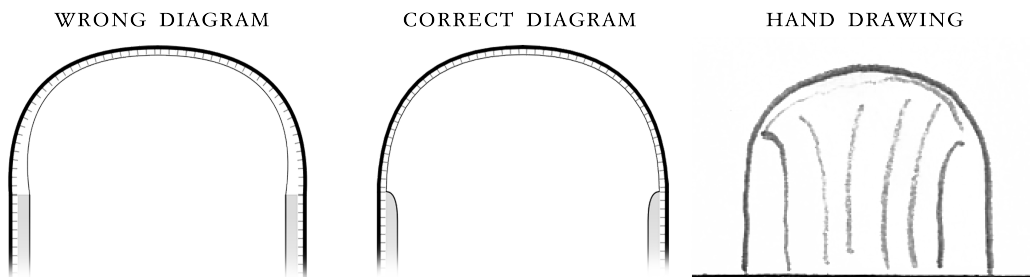

Figure 129. Example 3. Error due to inaccurate encoding, possibly because of typology misinterpretation. Spine shape and spine lining for volume 5.2β.

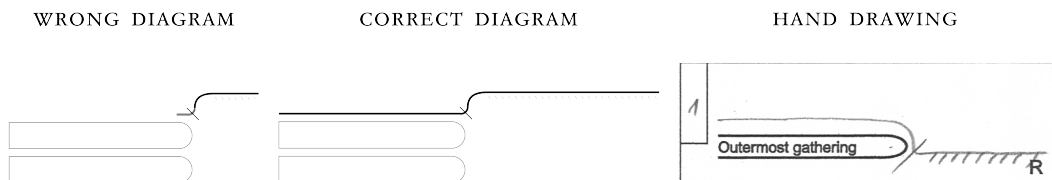

Figure 130. Example 4. Slip error during encoding. Right endleaves for volume 236.115.



In example 1 (Figure 127), as mentioned above, the surveyor did not encode the structure correctly. The correct diagram was generated by encoding the description appropriately – i.e. one integral endleaf and one group of separate endleaves constituted by two units. This kind of problem can be avoided through data validation by rendering the repetition of the same endleaf type within one structure invalid.

In example 2 (Figure 128), the surveyor did not follow the component numbering convention. A wrong unit order leads to nonsensical diagrams. Tweaking the data to follow the numbering convention generates a correct diagram.

Examples 3 (Figure 129), shows a spine lining diagram for which the spine shape joint typology were inaccurately selected. This is possibly due to a misunderstanding of the joint categories set by the description schema. In the dataset the joints are described as *slight*, which leads to an odd looking diagram. However, the hand drawing shows that the surveyor picked the wrong joint type. The distinction between the various abstract joint types can be difficult to appreciate. The volume had, in fact, *quadrant* joints. By changing the joint typology and re-generating the diagram, the shape coincides with what had been drawn, and this eliminates the gap between the bookblock and the lining at the joints.

Example 4 (Figure 130), shows an obvious slip in the selection of the endleaf component type. The XML description indicates the endleaf as a *guard*. However, the hand drawing clearly shows a *fold* type.

Table 2 categorises the examples according to their cause and states whether they could have been avoided with effective data validation. Only example 1 was avoidable through validation routines. As discussed in chapter 5, data that is not ‘valid in the first sense’ — i.e. determined by the rules of its language — can be avoided through validation routines. Ambiguities due to human error that cause ‘invalidity in the second sense’ — i.e. determined by context — are, instead, not avoidable through data validation, and can only be checked against reality. For each example, the table shows whether it is not ‘valid in the first sense’ or ‘the second’. Examples 1, 2 and 3 are not ‘valid in the first sense’. Their invalidity is ruled (and identifiable) by the grammar of the schema (example 1, which makes it possible to validate this error through automated routines), and by the fact that

Example #	Error cause	Avoidable through data validation	Validity sense (I or II)	Validity sense ruled by
1	schema convention misinterpretation	Yes	I	schema & object form
2	descr. convention misinterpretation	No	I	object form
3	inaccurate encoding	No	I	object form
4	slip during encoding	No	II	object context

Table 2. Table showing the cause for each error example, whether it would be avoidable through effective data validation, whether it is invalid in the first or second sense and the language or context ruling its invalidity.

the diagrams do not show a configuration that would be possible in real life. Example 4, instead, is not ‘valid in the second sense’ and its validity is therefore context related: what the diagram shows is possible, but not true.

This thesis proposes the use of visual means to solve these validation problems. Diagrams, as visual communication systems, naturally offer information in a synchronic manner and could immediately highlight errors.<sup>467</sup> The next section introduces how this could be possible.

### 7.3.2. THE FEEDBACK LOOP

In order to explain the value of diagrams as validation tools, it is important to discuss the communication cycle diagram introduced in chapter 1 (reproduced here in Figure 131). One could notice a feedback loop that connected the human observer back to the object that started the communication cycle. The concept of a communication feedback is a common feature in communication theories.<sup>468</sup>

---

<sup>467</sup>. Campagnolo 2014a.

<sup>468</sup>. Rothwell 2012.

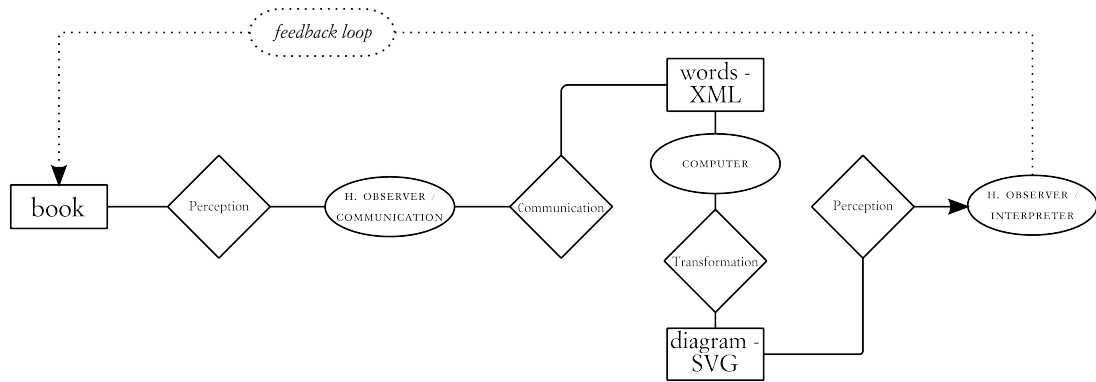

Figure 131. Communication cycle for the project, highlighting the feedback loop between the human observer at the end of the cycle and the object being described and visualized at its beginning.

In this project, there is an extra step between the coding of the information and its delivery, as this is re-coded by the computer into a visual message. The feedback loop in this particular communication cycle can then take on a different role and meaning. The feedback could in theory be connecting not a different person to which information about the object is being communicated, but the person who encoded the information in the first place. This was obviously not the case for the St. Catherine’s survey. However, it is possible to foresee a system that integrates the kind of automated transformations described in this research directly within the surveying process. In such a case, the feedback loop would be linking the observer with the object being described, and the observer would be receiving the same information that was input into the system, but in a different form. A form that being visual is more immediate and synchronic.

Although it has not been possible to test the feedback loop exploitation in a large scale. All of the errors listed above — and many more — have been identified thanks to the automated diagrams. It would be, however, interesting to test the efficacy of such a system in a project and check whether the reliability of the human surveyor does indeed increase and how much does this affect the speed of the surveying process.

It is likely that, had this system been in place for the 2007 survey, some of the mistakes registered in the dataset would not have occurred. The feedback loop would have acted as a proof of truthfulness against reality for the descriptions.

Let us say that  $p$  is the structure to be recorded and that, for any reason,  $non-p$  is instead input in the database. If  $non-p$  is allowed by the schema, the incorrect information will not be captured by data validation and remain in the dataset. If, through an extra step,  $non-p$  is presented again to the encoder, it is probable that  $non-p$  would be corrected into  $p$  and the mistake would be amended.

This system would not circumvent all kinds of errors. If an error is a knowledge-based mistake in the interpretation of the evidence the feedback to reality would probably still afford the same incorrect interpretation. However, based on the empirical experience accrued during this work, it would seem probable that most of the skill-based lapses and ruled-based mistakes presented here would be avoidable with the application of this system to the surveying process.

## Summary

This chapter presented a detailed analysis of the transformation for endleaf structures. The rest of the other transformations have also been introduced. Some noteworthy mistakes and problems in the schema and the dataset have also been highlighted.

Any system has to take into consideration the human factor, and the errors that are likely to make their way in the dataset because of it. Empirically, it seems that the implementation of a system like the one presented in this research that is able to take the data that has been recorded, and present it again to the surveyor in a different form, might lead to less erroneous data in the dataset.

The following chapter draws from the thesis a series of methodological considerations for automated intersemiotic translations.

# Chapter 8. Recommendations

*Und so verhält es sich in der Philosophie überhaupt: Das Einzelne erweist sich immer wieder als unwichtig, aber die Möglichkeit jedes Einzelnen gibt uns einen Aufschluss über das Wesen der Welt.*

*And that is generally so in philosophy: again and again the individual case turns out to be unimportant, but the possibility of each individual case discloses something about the essence of the world.\**

Ludwig Wittgenstein, *Tractatus logico-philosophicus*, 1922.

\*translation by Pears & McGuinness (1961).

Before drawing the final conclusions of the thesis, this chapter discusses the transformation process, and considers the methodology for successful automated intersemiotic translations based on models *of* material objects.

## 8.1. Intersemiotic translations: methodological recommendations

At the beginning of the project it was argued whether it would be possible to gather enough information for successful automated visualizations from a model *of* a material object, as opposed to produce a drawing interface for end-users based on semantic models *for*.

From the analysis of the issues and considerations mentioned throughout this dissertation, it is now possible to advance a series of methodological recommend-

ations that should be followed in the design of systems for the automated intersemiotic translation and diagrammatic visualization of material objects based on models *of*.

#### 8.1.1. INTERSEMIOTIC TRANSLATION ELEMENTS

**In intersemiotic transformations, there has to be a one-to-one relationship between the components of the verbal propositions and those of the visual propositions.**

Translation from one language into any another language is attained by translating all components of the proposition *a* in language A into the components of a proposition *b* in language B. Each component in proposition *a* is represented by a sign, whose meaning is common to the sign that substitutes it in the proposition *b*. In this project, a proposition *a* is encoded verbally and is translated into a proposition *b* encoded graphically. It follows that each component in proposition *a* finds its counterpart in proposition *b*, i.e. for any element described verbally, something should be drawn.

#### 8.1.2. FUNCTIONAL VERBAL DESCRIPTIONS

**For an automated intersemiotic translation system to be functional, the verbal information has to be structured. Structured descriptions can convey information on material components of material objects, and their form, maintaining a reference to the logical form.**

**This is achieved through: controlled vocabularies, the hierarchical organization of information, and the schema of the description.**

Amongst the different kinds of verbal descriptions of bookbinding structures, controlled vocabularies and structured descriptions have been found to be the strategies most successful at conveying the minimum information.

The selection of precise terms and definitions, even if not referring to atomic elements, makes them capable of conveying information on both the material components and the form of the element being described. However, the term should refer to the basic level of abstraction of the category that it describes, or else indeterminateness would render its use as reference point unsuitable for visualization purposes. In the St. Catherine's schema there are examples of controlled vocabulary terms that fail to define their category at the basic level of abstraction. Examples that have already been highlighted in the previous chapters are those used for furniture items other than fastenings — e.g. *bosses* and *ties* — or *laced and tacketed* case covers, as opposed to *strap plates* or *strap collars* and *cover lining* case covers. The elements defined within controlled vocabularies are prototypical examples of their categories, and, if used at the right semantic entry point level, they maintain a reference to the logical form of the elements described. The definitions convey information about their form and parts, and also, sometimes, about their relative position in relation to other elements. Think, for example, of the definition of an endband's crowing core: 'a subsidiary core which sits on top of the main core'.<sup>469</sup> Here, the definition provides relative spatial information. This information is obviously domain specific. The technical vocabulary of classical architecture is extremely well developed in these respects.<sup>470</sup> For a useful description, these defined elements, even if non-atomic, should still refer to smaller parts of the whole being described, or else, if not further described through other smaller elements of which they are composed, they risk being too general and indeterminate.

In structured descriptions, each element is in hierarchical relationships with the others, and its position within the hierarchy can carry information in regards to its position in space in relation to the others. For example, the arrangement of various endleaf components can be placed spatially based on the hierarchical description of the structure. Let us consider again the example in the previous chapter and reported here in Figure 132. In this case the item numbering convention (from outside to the inside) was not followed. It was the incorrect hierarchy

---

<sup>469</sup>. Ligatus 2013.

<sup>470</sup>. Goulette 1999; Borillo & Goulette 2006.

caused by the erroneous encoding that produced an impossible diagram, and not the incorrect use of some components. In other words, in the description, the object's components were all correct and present, but the way they had been encoded — i.e. their place in the description hierarchy — resulted in an impossible diagram. Correcting the hierarchy yields a correct diagram.

Behind the hierarchical structure of the descriptions lies the model of the information to be gathered, and this model is encoded within a schema. The schema, acting like a recipe for a particular binding component, is the expression of the logical form of that component. Provided that the model behind the schema is well developed, complying with the schema, a structured description is capable of portraying any instance of the binding component.

The schema guides the human user in describing an object in accordance with its model *of*. Following the schema, it is possible to algorithmically extract the relevant information from the descriptions, and transform this into a graphic representation. The transformation algorithms act as models *for* the generation of the diagrams. The algorithms can be compiled successfully in virtue of the schema — i.e. the model *of* the material object — acting as a reference to the logical form of the object. Without this, as it was the case of natural language processing projects outlined in chapter 2, any sure link to the logical form of the object is lost, leading to indeterminateness, especially for spatial information.

### 8.1.3. THE NATURE OF SEMEMES IN DIAGRAMS

**In diagrams, the shape of each element depends on that of the adjacent units, sememes are interdependent, and gaps have to be avoided, as informational lacunae are read as absence of phenomena, and not as missing data.**

Unlike verbal propositions, the units of images are seldom discreet and with clear boundaries. They can be generated in accordance to the one-to-one relationship with the elements of the verbal description, but their final shape will generally depend on that of the adjacent units. Working in a combinatorial way, element by element, the whole image text can be parametrically constructed.



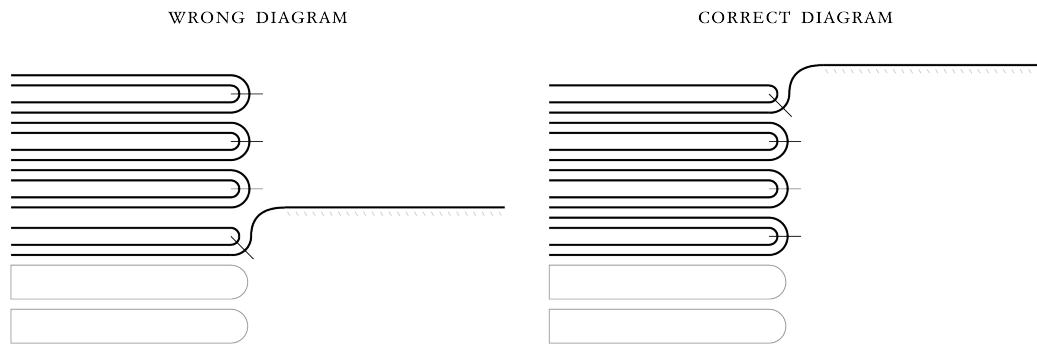

Figure 132. Errors in the hierarchical arrangement of the elements result in wrong spatial relationships. Right endleaves for volume 5365.3471d.

Diagrams, by a semiotic point view, are visual texts, whose sememes are woven together and are interdependent in relation to their meaning. This has important consequences for the generation of automated intersemiotic translations, as the generation of each visual sememe necessarily has to depend on the other sememes present in the current diagram, and on the overall visual text.

In visualizations, one should not leave or form gaps of graphic information, or the risk is to alter the meaning, or to render the whole visualization meaningless. The plane on which visualizations develop is continuous as it can be infinitely subdivided. One can distinguish between signifying and non-signifying parts of the plane. It is difficult to disregard a part of the signifying plane, as *zero signs* are read as absence of phenomena, not as missing data. Since in visual texts, sememes are interdependent in their meaning, the absence of one part can alter the meaning of the other parts and of the whole proposition.

#### 8.1.4. PROTOTYPICALITY OF INFORMATION

**Words convey prototypical information. Visualizations derived from verbal descriptions are necessarily prototypical in nature. Visual percepts are recognized and labelled according to a clear-cut entity reference framework tending towards best (regular) examples. Prototypical representations do not convey the specificity**

**of an object. The prototypicality of visualizations is however not a shortcoming as this facilitates priming and memorization.**

Material objects are recognized as part of their category through reference to best example prototypes. Typically, these prototypical instances represent a particular level of abstraction. It is at this level that one mostly interacts with objects, gives them labels and names. In addition, it is at this level that the parts which constitute objects are also identifiable through simple verbal labels. Thanks to this, at this level of abstraction it is possible to form a mental image that will resemble the appearance of all the members of their category. Any automated translation of information conveyed through verbal labels will necessarily be prototypical.

Prototypes are inclusive in nature, and specific only in regards to some fundamental features of the category they represent. This leads to a certain level of indeterminateness as the specificity of an object cannot be portrayed through prototypical information alone. The human mind classifies shape percepts as instances within a categorical system in which only some features are perceptually fundamental. Percepts are recognized and labelled according to a clear-cut entity reference framework. Verbal descriptions, making use of these clear-cut verbal labels, lack therefore the ability to deliver the specificity, the precise appearance and shape of objects.

When dealing with visual perceptions, perceived shapes are matched up with the prototypical mental images of their category. Prototypical visualizations, offering surrogate stimuli, can be used as instruments of abstract visual reasoning. Mental representations of visual information possess structural and spatial characteristics. Every part of an object and its spatial relations are encoded in mental representations, and this information, which is not usually available to language-base thinking, is, however, readily available for thought processing.

The prototypicality of visualizations is not a shortcoming as their standardized and essential appearance augments their immediacy and facilitates the comparison with other exemplars. In fact, it induces visual priming,<sup>471</sup> as similar patterns

---

<sup>471</sup>. Priming: an implicit memory effect in which exposure to one stimulus influences a response to another stimulus (Ware 2013). See Appendix A.

between different visualizations remain similar, whilst only patterns that signal different information change. Priming allows comparing, identify differences, and remember similar images even if the information is not consciously perceived.

#### 8.1.5. GRAPHIC PROTOTYPES

**Diagrammatic representations can be generated from verbal descriptions, if the minimum information is conveyed through the process. Graphic prototypes do not need to be naturalistic drawings, but can be stripped down to their essence and schematized. This is true also if they are communicated through iconic signs. When presented as two-dimensional, pattern recognition and comparison is facilitated.**

In a communication process, information is conveyed through the cycle, from the sender/encoder of the message, to the receiver/decoder. In the specific case, one starts with the encoding of information regarding bookbinding structures by part of a human interpreter within a verbal description. Then, the information is parsed by an algorithm, which can transform it into a series of diagrams. At each stage of the chain, the minimum information has to be preserved for the automated diagram generation to be possible. Minimum information is information on the material components of the object described, its form, and a reference to its logical form. This reference to the logical form can in turn be used to inform the transformation algorithm design.

A sign signifies its object only in virtue of certain features possessed by it (or its perception) as the result of a process of selective abstraction. A sign — even an iconic sign — can be generated through an abstraction and generalization process.

Three-dimensional representations can make it harder to compare features between similar items as human pattern perception resources are for the most part devoted to planar information as opposed to depth, and shapes are distorted when presented in three dimensions on the plane.

#### 8.1.6. FIXING THE MEANING OF VISUAL SEMEMES

**In visual texts, the meaning of sememes can be fixed with the use of additional information in the form of reference elements and verbal labels.**

The natural tendency to polisemy of visual signs can be fixed through the integration of verbal labels, visual information within the same diagram, and the presence of graphic reference elements. These elements allow for correct reading of the information in *beta modality*, i.e. to access information other than just the immediate visual appearance of the signs.

#### 8.1.7. UNCERTAINTY

**For scholarly research, both uncertain data and uncertainty that is the result of the visualization process need to be flagged.**

Not highlighting what is uncertain within a visualization is to express complete conviction and absence of doubt. This would not be regarded as good practice in any scholarly research, and yet, often uncertain information is not appropriately flagged within visualizations. Within scholarly research projects visual information should convey uncertainty where needed. The visualization process should allow the recognition of what data is uncertain, and which parts are uncertain as the result of the visualization process itself.

### **8.2. Recommendations for the communication of bookbinding structures**

All of the considerations presented in this chapter are applicable to any material object and are not specific to bookbinding structures. However, considering that this project dealt with the application of these principles to the field of bookbinding studies, and considering the peculiarities of the field as presented

in chapter 4 — its lack of standards in particular — it is useful to draw some general conclusions here.

As seen in chapters 4 and 5, unstructured verbal descriptions of bookbinding structures, which are unaccompanied by graphic representations, lack the ability to convey enough information for a reader to derive one and only one possible interpretation of what was described, i.e. they are under-specified and under-developed, as these are not capable of successfully conveying the form of binding structures. Whilst the precise canon of rules of composition of classical architecture leads to the efficacy of its controlled vocabulary as a means of conveying also spatial information, there is no such canon for the composition on the elements of bookbinding structures. Structured descriptions coupled with a precise control vocabulary allow to overcome this problem, as, by offering information in an orderly and prescribed manner, they provide a more complete representation of the logical form and its inherent possibility to indicate any form. Therefore, structured descriptions of bookbinding structures are capable of conveying the core pieces of information for their successful communication, and, in turn, the production of successful intersemiotic translations.

In a similar manner, the lack of standards in the graphic representation of bookbinding structures can hinder communicability and comparative analysis between similar structures in different books recorded by different scholars. This problem can be overcome with the generation of graphic prototypes, i.e. exemplars which select only the minimum amount of information needed for successful communication of bookbinding structures. In addition to this, standardized graphic conventions allow the integration of uncertainty visualization within bookbinding diagrams, thus fostering scholarly transparency also within graphic representations, and not just within textual communication.

The recommendations outlined throughout this thesis, and summarized in this chapter, allow better communicability and shareability of information on bookbinding structures, both through verbal structured descriptions, and through standardized graphic representations. Even if the main purpose of this project was the evaluation of the possibility of automatically generating bookbinding structure diagrams from verbally encoded descriptions, the analysis of the descrip-

tion problems encountered in the course of the project is a useful example to follow to describe bookbinding structures in general, as successful intersemiotic translations need, in the first place, successful descriptive models.

Szirmai<sup>472</sup> correctly identifies the lack of a systematic vocabulary, terminological clarity, and a precise recording system as the main problems encountered when scholars attempt to describe bookbinding structures, and this inevitably hinders progress in the field. This research, on the one hand, provides a reference framework to develop efficient vocabulary and description systems applicable to bookbinding structures, and on the other offers guidelines for the standardization of graphic representations of bookbinding structures, with the inclusion of uncertainty in the data and in the visualizations.

## Summary

Drawing from what exposed in the course of this thesis it has been possible to put together a series of methodological recommendations to take into consideration for a system attempting to perform intersemiotic translations of the kind described in this project. These consider the main steps of the visualization and communication process. They consider which verbal description is best suited to convey the minimum information for successful visualization, the prototypicality of verbal and graphic information, the nature of the meaning bearing parts of visual languages, the relationships between the elements in the two languages involved in the intersemiotic translation process, and the presence of uncertainty in the data and in the visualizations.

The next chapter draws the final conclusion for the thesis and states the contributions that this project has made.

---

<sup>472</sup>. Szirmai 1999.

## Chapter 9. Conclusions

*The pattern of the thing precedes the thing.*

Vladimir Nabokov, *The Art of Fiction No. 40*, *The Paris Review* #41, 1967.

The novel contributions of this study include:

- methodology recommendations for successful automated intersemiotic translations,
- the production of transformations for the domain of bookbinding studies,
- design recommendations for the generation of standardized automated prototypical drawings of bookbinding structures,
- the application of uncertainty visualization to the field of the archaeology of the book.

This project investigated the transformation of verbal information, which described material objects such as bookbinding structures, into visual representations as part of an automated process. Intersemiotic translations pose a number of issues, and practical considerations that have been described in the course of this thesis. The following sections will summarize the principal points covered and state what contributions were made during this project.

## 9.1. Successful automated intersemiotic translations

This research posed a question about the kind of information needed for a successful visualization of bookbinding structures, or other material objects. The literature review did not highlight any previous work on the matter. It is now possible to identify this core information. A project that attempts a passage of information about material objects from verbal descriptions to graphic representations should consider at first if these core pieces of information are available. This is a primary contribution of this research project.

**[C1.0] Transforming verbal descriptions to visual representations automatically is possible, if the following core pieces of information are available:**

- 1 whole/part relationships: the verbal description conveys information about the material components of the object.**<sup>473</sup>
- 2 spatial configuration of parts: the verbal description conveys information on the form of the object.**<sup>474</sup>
- 3 rules of composition of the object: the verbal description maintains a reference to the logical form of the object being described, and this information can inform the transformation algorithm design.**<sup>475</sup>
- 4 prototypical shape: it is possible to generate a prototypical shape from verbal descriptions.**<sup>476</sup>

Chapter 4 presented different types of description of historical bookbinding structures. All of these were able to enumerate and name all the relevant material components of the object being described, but most were not capable of communicating its form successfully through strictly verbal means, i.e. the spatiality of the elements. This creates problems in subsequent readings and analysis. The re-

---

<sup>473</sup>. §3.4.1, §3.4.1.1, §4.2.1-4, §5.1, §5.1.1, §5.1.1.1-2, §5.1.2, §5.1.4, §6.2, §6.2.3.1, §7.2.6, §8.1.2, §8.1.5. The numbers indicate the sections within the text where these points have been described and argued.

<sup>474</sup>. §3.4.1, §3.4.1.1, §4.2.1-4, §5.1, §5.1.1, §5.1.1.1, §5.1.1.2, §5.1.2, §5.1.4, §6.2, §6.2.3.1, §7.1.4, §7.2.4, §7.2.6, §8.1.2, §8.1.5.

<sup>475</sup>. §3.4.1.2, §4.2.3-4, §5.1, §5.1.1, §5.1.1.1-2, §5.1.2-4, §7.2.4, §8.1.2, §8.1.5.

<sup>476</sup>. §3.3.1-2, §3.4.2, §3.4.2.1-4, §4.3, §4.3.1.2, §4.4.3, §5.1.1, §8.1.4.



lationship between a whole and its parts, and the configuration of the parts are all essential elements for the communication of the essence of an object. Structured descriptions coupled with controlled vocabularies are capable of overcoming these limitations of verbal communication.

For a successful automated translation from verbal to visual descriptions of material objects, the capacity of conveying the form of objects is not in itself sufficient. One needs to be able to refer to the 'recipe' of that particular object, i.e. its logical form. Through this reference to the logical form, both kinds of propositions, verbal and graphic, adhere to the same model of the material object being described, and the automated intersemiotic translation can take place.

Percepts are recognized and labelled as tending towards clear-cut entities. Verbal descriptions lack the ability to deliver the specificity, the precise appearance and shape, of objects. However, this labelling system allows the successful communication of general information about the visual aspects of reality. Labels at the basic level of abstraction allow a mental image to be formed that resembles the appearance of members of the class as a whole. When provided with labels at the correct level of abstraction it is possible to establish and draw a prototypical shape for objects and their components.

Based on the analysis of the issues and considerations mentioned throughout this thesis, this work has advanced a series of methodological recommendations, laid out in chapter 8, that should be followed in the design of systems for the automated intersemiotic translation and diagrammatic visualization of material objects, and of historical bookbinding structures in particular. These methodological recommendations constitute another important contribution of this project.

#### 9.1.1. SUMMARY OF THE RECOMMENDATIONS

Automated intersemiotic translations require that information on both the material components of material objects, and their form may be verbally encoded. It is also necessary that a reference to the logical form of the material object is

maintained and that this is available for the compilation of the transformation algorithms. Structured descriptions and their schemas are capable of satisfying these requirements and can therefore be recommended as good and feasible examples of verbal descriptions.

In designing the transformation algorithms, one should keep a one-to-one relationship between verbal and graphic elements. It should also be noted that the shape of the elements to be drawn is likely to depend on that of the adjacent and concurrent elements within the visual text being generated. Care should be taken not to leave or form gaps of graphic information in the diagrams.

The diagrams generated are necessarily prototypical in their design and shapes. This permits the standardization of the output diagrams, and subsequent ease of comparison between different exemplars. Prototypical shapes can be generated from verbal labels through a regularization and generalization process.

The meaning of diagrams and their sememes can be fixed with the use of graphic reference elements and verbal labels. Uncertainties in the data and in the visualization have to be flagged through visual cues. These cues need to be applicable without disturbing the perception and identification of the diagram shapes, and their connection with uncertainty should be easily interpreted.

## 9.2. Visualizations from models *of*

**[C2.0] It is possible to draw the minimum information for successful automated visualizations from models *of* a material object.<sup>477</sup>**

In chapter 2, the possibility was advanced of being able to transform automatically information contained in models *of* an object into graphic representations. In the cultural heritage field, it has been customary to implement semantic modelling interfaces that are based on models specifically designed for the task. Also, often, these interfaces integrate direct acquisition data into the modelling process.

---

<sup>477</sup>. §2.1, §2.1.1, §2.2.3, §2.3, §8.1, §8.1.4.

These allow an artefact to be modelled without having to deal directly with geometric primitives such as lines and planes.

From the experience accrued during this research project it is possible to conclude that models *of* are suitable for the generation of prototypical diagrammatic visualizations. A model *of* approach cannot be regarded as a substitute for the customary models *for* if the desired outcome has to reflect in detail the specificity of an artefact. However, prototypical graphic representations, which can be generated from models *of*, offer advantages when the desired outcome is to be compared between many instances of a class of artefacts: their prototypicality offer standardized and essential appearance, augments their immediacy, and facilitates the comparison with other exemplars by inducing visual priming.

### **9.3. Standardized automated drawings of bookbinding structures**

As seen in chapter 4, there is no standardized way of depicting bookbinding structures in drawings. This project has brought together a series of schematic depictions of bookbinding structures that, following common design principles, and being automated, are by nature uniform in their appearance. These design considerations are applicable to other material objects, but considering the lack of any standard in drawings within the field of the archaeology of the book, these are a particularly important contribution to this research area, and not just for automated drawings and their particular formation constraints. Following these guidelines, illustrations of bookbinding structures depict a selection of attributes that are of academic interest to the scholar or the conservator, while many details not considered relevant to the research are omitted, and they can facilitate comparative analyses with other studies and structures, thus fostering communicability of information regarding bookbinding structures.

**[C3.0] Bookbinding structures are efficiently represented by prototypical line drawings.**<sup>478</sup>

Amongst the various types of drawings of bookbinding structures found in the literature, line drawings are able to convey the minimum required amount of information, but are simple enough to be readily interpreted, understood, and remembered. Also, as iconic signs, they do not need to be naturalistic.

**[C3.0.1] Two dimensional line drawings are sufficient for shape recognition as they are capable of capturing the essential shape and form of an object without the need for colour information. They can be used as iconic signs resulting from the abstraction of shape perception information**<sup>479</sup>

There are many perceptual characteristics possessed by objects, e.g. colour, texture, shading, etc. Amongst the various visual properties, shape is the most prominent for unambiguous identification. Figure-ground organization is achievable even if only the outline of the objects is preserved, and the visual information is simplified and reduced to the bare minimum. Black and white planar line drawings are therefore sufficient for shape and pattern recognition and can be used as iconic signs resulting from the abstraction of shape perception information. As human pattern perception resources are for the most part devoted to planar information as opposed to depth, for easy of feature comparison two-dimensional representations are to be preferred.

**[C3.1] Graphic prototypes of bookbinding structures can be generated as the result of the abstraction by simplification, regularization, symmetrization, and preservation of other *prägnant* features.**<sup>480</sup>

Shapes are perceived visually as tending towards more regular shapes to which they are seen as similar or equivalent, and these more regular shapes, as seen in C4.1, are labelled for categorical organization. Shape prototypification is a process

---

<sup>478</sup>. §4.4.3, §6.2.3, §8.1.5.

<sup>479</sup>. §3.4.2.3, §5.2.3.4, §8.1.5.

<sup>480</sup>. §3.4.2.2-4, §8.1.5.

of simplification, regularization, symmetrization, and preservation of other *prägnant* features that are essential for the recognition and labelling of percepts.

**[C3.2] Graphic prototypes of bookbinding structures have to preserve and communicate their objects in a psychologically sound manner, taking into consideration the mental representation capacity of the end users.<sup>481</sup>**

Psychologically, there are systematic differences between perceptual displays and their mental representations. Effective graphic representations should ensure that the content and form of the visualization correspond to those of the desired mental representation and that these are readily and correctly perceived and understood. For this, to preserve and communicate in a psychologically sound manner the composition of the object represented along with its form, and the spatial relations amongst its material components, one may need to rely on exaggeration of some features and accurate but imprecise spatial relations, separating information into discernible visual groups.

**[C3.3] Graphic prototypes of bookbinding structures are mostly ruled by *ratio difficilis*: their generation needs both to follow those few conventions established in the literature, and to balance naturalism of shapes and symbolism. The shapes selected need to be consistent and need to avoid creating confusion with other shapes.<sup>482</sup>**

Drawings of bookbinding structures have never been formalized, and their appearance tends more towards iconism than symbolism. For these reasons, these drawings are mostly ruled by *ratio difficilis*. As a consequence, one needs to follow what few conventions can be seen as established in the literature — if indeed these comply with the general design principles proposed here — as these, allowing some degree of *ratio facilis*, render the diagrams easier to remember and reproduce for the initiated. For diagrams, or parts of diagrams, that instead lack conventions, the shapes need to tend towards iconism, i.e. generated and presenting themselves

---

<sup>481</sup>. §3.4.2.4, §4.5, §5.2.3.2, §6.2.3.3, §8.1.5.

<sup>482</sup>. §3.1.2.2, §4.3.1.1-2, §6.2.3, §6.2.3.2.

in accordance with their own content. In any case, within the whole visualization system, shapes should be consistent, and care should be taken not to create confusion mixing symbolic and iconic shapes that end up looking similar but with substantial different meaning, e.g. symbolic square outlines for gathering pages and iconic square outlines (see Figure 19[c]).

**[C3.4] Each drawing needs to show only the minimum amount of information, at the most useful level of detail.**<sup>483</sup>

Visualizations need to draw the part of the bookbinding structure that they represent showing only what is needed, thus not overwhelming the eye with irrelevant information. For example, endband views do not need to show the whole book, but only the head or tail sections.

### 9.3.1. SUMMARY OF DESIGN PRINCIPLES

Prototypical information on bookbinding structures can be successfully communicated graphically through monochrome and bi-dimensional line drawings. Being prototypical, the shapes can be generated through a prototypification process that preserves those *prägnant* features that are essential for the recognition and labelling of the objects. Information should be presented in a psychologically sound manner: some features can therefore be exaggerated and kept separate, and each drawing should show the most significant level of detail. Whilst the lack of standardized symbolism means that drawings need to tend towards iconism, any appropriate convention should be followed, but the resulting shapes should be consistent and clearly identifiable.

---

<sup>483</sup>. §4.4.4, §4.5.1, §6.2.3.

## 9.4. Uncertainty visualization in bookbinding studies

### **[C4.0] Uncertain data need to be flagged within visualizations of historical bookbinding structures for scholarly research.<sup>484</sup>**

As noted, the field of the archaeology of the book is young, and still developing. Certain information is scarce, and often the interpretation of bookbinding structures leaves significant space for educated guesswork and uncertainty. Nonetheless, nowhere in the literature, one finds cases of visualizations that show what information is certain, and what is instead a guess or completely uncertain. The problem of the visualization of uncertainty within drawings of historical bookbinding structures has never been addressed in a scholarly way, and this poses serious problems of interpretation when reviewing literature sources.

The generation of the diagrams for this project posed many issues with uncertain data, and for the first time, uncertainty has been flagged within visualizations of historical bookbinding structures. The integration of a systematic way to show what information is uncertain within bookbinding structure diagrams constitutes another contribution to the field made by this project; a contribution that alone, if followed in future scholarly work, could represent a significant improvement and advancement for the discipline.

### **[C4.1] Both uncertain data, and data that acquires uncertainty in its transformation to the visual need to be flagged within visualizations for scholarly research.<sup>485</sup>**

Visualizations within scholarly research projects should convey uncertainty where needed. The visualization process should allow recognition of what data is uncertain, and which parts are uncertain as the result of the visualization process itself.

### **[C4.2] Visual cues which are used to flag uncertainties within diagrams of material objects need:<sup>486</sup>**

---

<sup>484</sup>. §5.3, §6.2.3.5-7, §8.1.7.

<sup>485</sup>. §5.3, §6.2.3.5-7, §8.1.7.

<sup>486</sup>. §5.3.2.2, §5.3.2.2.1, §6.2.3.5-7, §8.1.7.

- to be applicable without changing the overall shape of the object,
- to avoid visual dimensions that have already been assigned other values — e.g. dotted lines,
- to avoid triggering unwanted Gestalt laws because of the interplay of particular uncertainty encodings — e.g. changing the figure/ground balance — and shifting attention.

Depicting uncertainty in diagrams whose shapes are dictated by those of the objects being represented, as in the case of material objects, poses particular issues and constraints. Visual cues need to be carefully selected to avoid adding extra coding to visual dimensions that are traditionally already used with different meanings, or that have already been assigned other values within the same visualization. The integrity of the overall perception of the shapes need not be precluded.

**[C4.3] Feasible visual cues for visualizing automatically uncertainty of material objects are: blurring, grey scale variation, transparency, fading, sketchy lines, and halos.<sup>487</sup>**

Various variables have been used to depict uncertainty; of these, blurring, grey scale variation, transparency, fading, sketchy lines, and the addition of a halo are those better suited to be applied to material object visualizations.

#### 9.4.I. SUMMARY OF UNCERTAINTY VISUALIZATION APPLICATION

In bookbinding studies, despite the fact that uncertainty is often inherent in the data collected from the artefacts, drawings and visualizations have never highlighted which information is uncertain. The visualization process should instead allow to recognize the parts that are uncertain. Uncertainty should be flagged without altering the overall meaning of the visualization.

---

<sup>487</sup>. §5.3.2.2.1, §6.2.3.5-7.



## 9.5. Added value & benefits of visualization automation

The generation of automated visualizations offers a series of benefits of significant added value. Each of these points shows how the implementation of a system capable of automatically visualizing information contained within structured descriptions can be beneficial. Therefore, the recommendations outlined in this project are in themselves a contribution, as, if followed for the successful generation of automated visualizations, they can advance and ameliorate similar data-gathering projects on material objects.

**[C5.0] Automated visualizations, if integrated with the description process, can work as a visual accuracy control system helping to identify meaningless or wrong data immediately, thus increasing accuracy of data within a database.<sup>488</sup>**

Data accuracy is an essential element for any database, but automated data validation systems cannot avoid all kinds of errors. If one were to integrate the generation of automated visualizations with the description process, the diagrams thus generated can help to immediately identify meaningless or incorrect data. They can function as a visual control of the accuracy of the data within a database, and this can eventually lead to better data being stored within the dataset.

**[C6.0] The automated nature of the visualizations, combined with the parametric and combinatorial character of their constitutive elements, renders the high number of possible permutations irrelevant.<sup>489</sup>**

The structured description schema leads the surveyor down description paths through choices and selections, and even for a limited number of options, this leads to a large number of possible visualizations. The drawing algorithm, following the same description paths, can generate suitable visualizations choosing, selecting, and parametrically generating the necessary elements, thus rendering the number of permutations irrelevant.

---

<sup>488</sup>. §5.3.3, §7.3.

<sup>489</sup>. §6.2.2.

**[C7.0] Information within structured descriptions is fragmented and dispersed within the database. The synchronic nature of visualizations reintegrates the information and helps in its analysis, by grouping it and freeing working memory.<sup>490</sup>**

Structured descriptions by nature fragment and disperse information within databases, or to present information in a highly condensed manner, as in the case of collation formulas discussed below. Human working memory limitations make it difficult to reintegrate or to reinterpret large amounts of information within the mind. If this information is instead presented within diagrams, the synchronic nature of visualizations naturally reintegrates or expands scattered or condensed information. In this manner, the diagrams, acting as exograms, are capable of helping with the grouping of the information and of freeing working memory, thus allowing easier analysis.

**[C8.0] Automated diagram generation can free survey time, increasing productivity.<sup>491</sup>**

During the St Catherine's Library printed book survey, as well as in other surveys, the surveyors both recorded verbal information within the database and sketched some structures on the survey form. The majority of these drawings are prototypical and schematic in nature. It follows that providing the surveyor with a system capable of generating prototypical schematic drawings automatically would increase production speed and be beneficial even just in this respect.

**[C9.0] Thinking about automated intersemiotic translations can inform schema design.**

The fact that the schema behind the dataset for this project was essentially a work in progress did not preclude the usefulness of this exercise. The schema's limitations, in fact, fed into the practical considerations along with all other problems met in the course of the XSLT code writing and the SVG generation. Furthermore, whilst the focus of the recommendations outlined in this research

---

<sup>490</sup>. §1.2.2, §4.2.4, §7.3.

<sup>491</sup>. §1.2.4, §1.3, §6.1.4.1.2-3.

was on the generation of the automated visualizations, the analysis of the description problems encountered in the course of the project — e.g. too general semantic entry point for binding elements, such as ties and other furniture elements (§6.2.3.1) — can prove helpful in the designing of new schemas to describe material objects, even if the generation of automated visualization is not part of the project. In fact, to be able to accomplish a successful intersemiotic translation, as stressed in the thesis, in the first place, one needs to be able to describe something properly and in a complete way. The considerations outlined here are of interest to anyone attempting to describe, to model, any material object in a useful way.

# Chapter 10. Future work

*It takes a good deal of maturity to see that every field of knowledge is the centre of all knowledge, and that it doesn't matter so much what you learn when you learn it in a structure that can expand into other structures.*

Northrop Frye, *On education*, 1988.

This project focussed on the generation of automated diagrams from descriptions of bookbinding structures: what kind of information is necessary, what descriptions can convey it, what are the implications of the transformation of the information into a graphic representation. Such a project could be extended to cover its practical application to the field and to other objects.

## **10.1. Integration of automated transformations within the data gathering framework**

In the near future, it is hoped to be able to offer the bookbinding description schema through a web interface that would allow anyone interested to describe their own bookbindings, ideally generating content for a central database of bookbinding structures.

During the development phase of this research project, it has become empirically clear that the automated visualizations can serve as data accuracy and error controls for the database. Their development also helped a great deal this author in better

understanding the subtleties of the description schema. It would therefore seem that integrating the generation of automated visualizations with the description process could positively affect the data entry process, both helping the non-initiated and the learner to better understand the description schema, and serving as visual proof of the data being entered, thus increasing accuracy.

It was not possible during this research to test and measure the psychological and cognitive effects of the automated visualizations on users and learners of the description schema during the data entry process. Such a study would however be highly desirable, as it could lead to even more efficient visualizations, and it could provide a measure of the efficacy of the diagrams as data accuracy and schema learning tools, beyond the mentioned empirical experience of these effects.

## **10.2. Verbal to visual and reverse: a mixed approach**

This project focussed on the process of taking information from models *of* a binding structure and transforming it into graphic form. Some bookbinding components require a long series of elements in order to be described properly. The more detail that is required, the more elements that need to be described, the more time that is necessary for the description.

Drawings are capable of providing complex information in a synchronic manner. It might be that complex structures could be presented to the user directly in graphic form for the desired one to be chosen, and to subsequently feed the relevant information into the database through a reverse visual-to-verbal transformation. There are problems with this approach, as one would have to foresee all possible alternative visualizations, generate them *a priori*, and present them to the user. In turn, the user would have to go through the numerous graphic alternatives and, through a spot-the-difference game, select the desired visualization. This might also influence negatively the accuracy of the information recorded, as the user, not guided by the schema through the option selection process, might not understand in sufficient detail the model of the description.

A solution which would be helpful to investigate is a mixed approach. One could describe a binding component down to a certain level of detail and have the system generate a series of possible alternatives. If the description level is appropriate, the number of alternative visualizations would be manageable. The information could be presented as a series of ‘small multiples’,<sup>492</sup> small illustrations provided with verbal labels which are positioned within the eyespan, so that the viewer is able to make comparisons at a glance. This way, the user would not be overwhelmed by the information and the differences between the visualizations would be evident. By selecting the desired option, the information could be transformed into verbal form for its inclusion in the database. Once again, there would need to be a one-to-one relationship between visual and verbal descriptions. Material components could take their verbal label, and spatial information could be translated into the structured arrangement of the information.

In the same way, this mixed approach could be used to solve uncertainty caused by insufficient schema development. The schema, for example, does not prescribe the path of the thread around double sewing supports. The most probable path is drawn, but then, on clicking on the uncertain path, the viewer could be presented with alternative paths, for the desired one to be selected and recorded in the database (see Figure 133).<sup>493</sup>

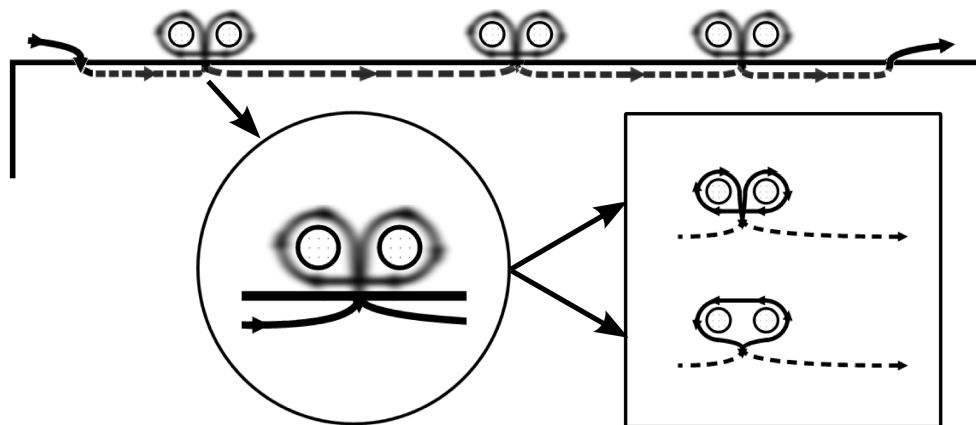

Figure 133. Small multiples to solve uncertainty due to schema limitations.

<sup>492</sup>. Tufte 1990, p. 67.

<sup>493</sup>. Campagnolo & Velios 2013.

### 10.3. Related work: Manuscript Collation Project

This project worked on XML structured descriptions of bookbinding structures. The schema used did not cover gathering assembly structure information. Chapter 4 highlighted the fact that in recent times, people have enquired whether anyone is working on a visualization of bookbinding structures. This project has brought forward the idea that structured descriptions are capable of providing the right information in a correct sign-language, i.e. one of the basic conditions for successful intersemiotic translations. The structured descriptions presented here have been encoded in an XML schema, and in fact all technologies involved have been strictly XML based. This does not have to be taken to signify that only highly structured and hierarchical XML schemas are capable of defining good structured descriptions.

During the work on this research, the author has been involved in a related but separate project on the visualization of manuscript collation formulas with colleagues at the Schoenberg Institute for Manuscript Studies, University of Pennsylvania: Dot Porter and Doug Emery. In the summer of 2013, Porter<sup>494</sup> posted on the TEI (Text Encoding Initiative)<sup>495</sup> distlist, asking whether anyone was visualizing with SVG collation formulas within TEI **msdescription** modules.<sup>496</sup> While data on the gathering formation was not available in the St. Catherine's schema, the transformation principles could definitely be adapted to new data and a different schema, so the collaboration began.

The information collected within collation formulas is highly condensed, but it follows a strict ruling schema. Collation formulas are thus a kind of structured description. Depending of the efficacy of the schema being implemented, collation formulas can communicate both the material elements — i.e. the leaves, the quires — and the form of gathering structures, and they also maintain a reference to the logical form of quire assemblies. Therefore, even if not encoded in XML, collation

---

<sup>494</sup>. Porter 2013.

<sup>495</sup>. Text Encoding Initiative Consortium 2014b.

<sup>496</sup>. Text Encoding Initiative Consortium 2014a.

formulas meet the basic conditions for the implementation of intersemiotic translations.

A first dataset was constituted by the Digital Walters collection.<sup>497</sup> This digital collection offered TEI P5<sup>498</sup> descriptions of manuscripts with an *ad hoc* developed collation formula schema.<sup>499</sup> Whilst simplistic, this formula was still able to convey the very basic information in regards to the gathering structure of those manuscripts. The formula within the TEI file was then parsed and the information was transformed into an XML file written in accordance with a new schema. Then from the XML, an XSLT transformation could take the information and transform the formula into a series of SVG diagrams, one for each gathering. These transformations are part of a larger Manuscript Collation Project,<sup>500</sup> and integrated within its webpages. The aim of the project is to provide the users with a view of a manuscript based not on facing pages, as it is customary with online presentations, but on the physical structure of quires, thus showing conjoined and not facing pages together. The diagrams help keeping track of which pages are being shown and their relationship with the others within the quire. At the time of writing, the project is still at the development stage.

This project shows how the methodology developed for this research is applicable successfully also to other structured descriptions and datasets. In practical terms, the methodology outlined throughout this thesis is applicable to the visualization of collation formulas for a number of reasons. First of all, collation formulas as a form of very dense structured descriptions that possess in their formation rules a reference to the logical form of the object that they describe. Secondly, collation formulas highlight whole/parts relationships (gatherings, bifolia, singletons) and their spatial arrangement (which element is contained by which other elements). Lastly, as mentioned in chapter 4, a prototypical shape for a folded bifolium can be expressed through rounded horizontal U-like signs.

---

<sup>497</sup>. Walters Art Museum 2014b.

<sup>498</sup>. Sperberg-McQueen & Burnard 2005.

<sup>499</sup>. Walters Art Museum 2014a.

<sup>500</sup>. Porter *et al.* 2014; Emery *et al.* 2014.



Quire 1 (8) Show All Hide All

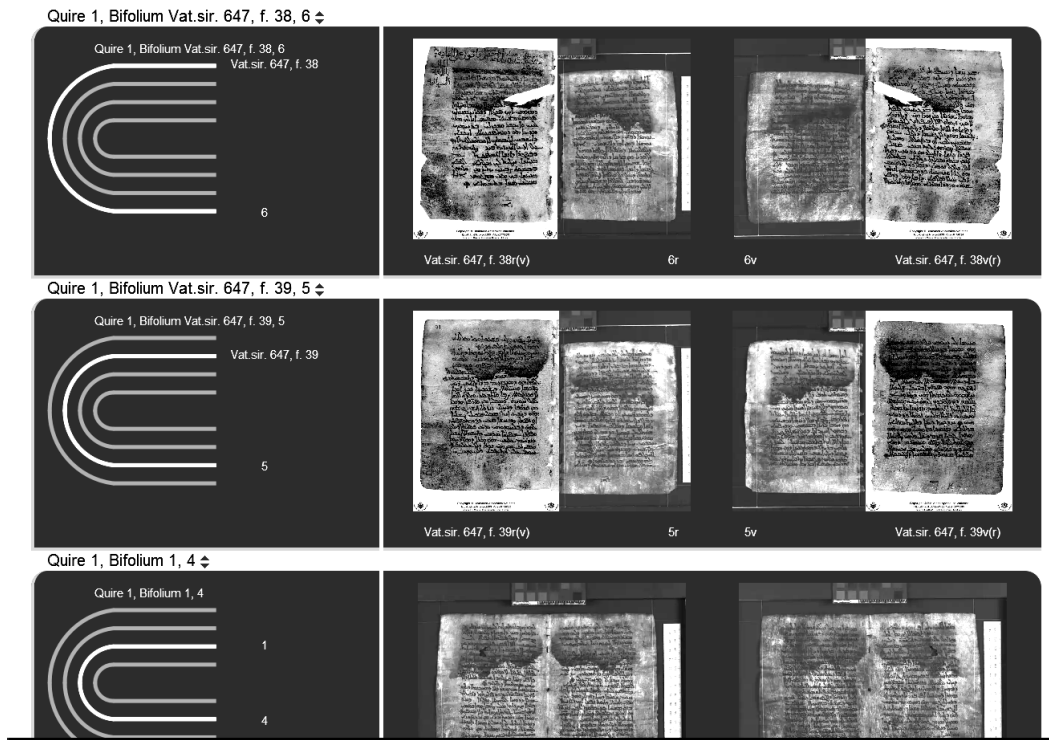

Figure 134. Screenshot from the Manuscript Collation Project webpage. Reconstruction of Quire 1 of the dismembered Galen Syriac palimpsest showing the proposed structure of the first quire of the original Galen manuscript (Toth *et al.* 2010; Toth *et al.* 2013; Bhayro *et al.* 2013). The pages shown come from the main corpus of the palimpsest and from the Vat.sir.647 manuscript, held at the Vatican Library. On the left are visible the diagrams generated from the collation formula.

Collation diagrams are not a novelty,<sup>501</sup> however, the diagrams for the Manuscript Collation project are a useful improvement. Being automated, in fact, they can act as a way of ensuring that data collected within collation formulas — or other collation description system — is correct, and they can also function as a simple visual aid to understand the structure of gatherings within books as they are generated — in a consistent manner — when needed.

<sup>501</sup>. See for example: Dennison 1990, Noel 1995, or Pickwood 2014a.

## 10.4. Final remarks

This dissertation has addressed the problem of whether and how it could be possible to transform a detailed description of a material object, such as a book-binding structure, into a visual diagram automatically.

This was essentially an intersemiotic translation problem. In order to investigate the issues related to such a complex problem, the research developed in two phases. First, it focussed on working from a theoretical perspective, attempting to extrapolate and apply existing theories from multiple disciplines, from semiotics, to cognitive psychology, perception, philosophy, and information visualization. This was inevitable, since one needs broad perspectives for an investigation into as general a problem as intersemiotic translations from verbally encoded information to a visual output. Second, the project took a more practical approach, by delving into the application of the theoretical framework researched in the first part of the project to a specific domain, i.e. bookbinding structures, and producing automated intersemiotic translations for such a domain. Although exposed here in sequence, the two phases of this research happened in tandem and in a cyclical way, each informing the other of the problems that needed considerations and of the possible solutions; theoretical consideration found their application in the visualizations, and visualization problems found their solutions in the theoretical framework.

This research showed that verbal-to-visual transformations based on models *of* are possible and that they can successfully convey the wanted information, if certain criteria are met. This project has advanced a series of methodology recommendations for successful automated intersemiotic translations, and design recommendations for the generation of standardized automated prototypical drawings of bookbinding structures. For the first time, uncertainty has been systematically flagged within visualization in the field of the archaeology of the book. It was also found that the automation of the visualization brings in a series of added value benefits of significant practical value, demonstrating the benefits of the implementation of a system capable of automatically visualizing information contained within structured descriptions.

# Bibliography

NB: the symbol  $\neg$  indicates that long URLs are broken across lines for justification purposes.

- ADAMS, Thomas R. and BARKER, Nicolas (1993), 'A new model for the study of the book', in BARKER, Nicolas (Ed.), *A potencie of life: books in society, the Clark Lectures 1986-1987*, London: British Library, pp. 5-43.
- ADLER, Georg (2010), *Handbuch Buchverschluss und Buchbeschlag: Terminologie und Geschichte im deutschsprachigen Raum, in den Niederlanden und Italien vom frühen Mittelalter bis in die Gegenwart*, Wiesbaden: Reichert Verlag.
- ADORNI, Giovanni, DI MANZO, MAURO, GIUNCHIGLIA, Fausto (1984), 'Natural language driven image generation', in *Proceedings of the 10th International Conference on Computational Linguistics and 22Nd Annual Meeting on Association for Computational Linguistics*, Stroudsburg, PA, USA: Association for Computational Linguistics, pp. 495-500.
- AGRAWALA, Maneesh (2001), *Visualizing route maps*, PhD Thesis, Stanford University, Stanford (CA), [http://graphics.stanford.edu/papers/maneesh\\_thesis/thesis.pdf](http://graphics.stanford.edu/papers/maneesh_thesis/thesis.pdf) (Accessed 2013-02-08).
- AGRAWALA, Maneesh, LI, Wilmot, BERTHOUSOZ, Floraine (2011), 'Design principles for visual communication', *Communications of the ACM*, 54, pp. 60-69.
- AGRAWALA, Maneesh and STOLTE, Chris (2001), 'Rendering effective route maps. Improving usability through generalization', in *SIGGRAPH 2001, SIGGRAPH*, Los Angeles (CA): SIGGRAPH.
- ALBERT, Marc K. and HOFFMAN, Donald D. (1995), 'Genericity in spatial vision', *Geometric representations of perceptual phenomena*, pp. 95-112.
- ALBERTAZZI, Liliana (Ed.) (1999), *Shapes of forms: from gestalt psychology and phenomenology to ontology and mathematics*, Dordrecht; Boston (MA): Kluwer Academic.
- ALLOWAY, Tracy P. and ALLOWAY, Ross G. (Eds.) (2012), *Working memory: the connected intelligence*, New York (NY); London: Psychology Press.
- ALLWEIN, Gerard and BARWISE, Jon (Eds.) (1996), *Logical Reasoning with Diagrams*, Oxford; New York (NY): Oxford University Press.

- ALPERS, Svetlana, APTER, Emily, ARMSTRONG, Carol, BUCK-MORSS, Susan, CONLEY, Tom, CRARY, Jonathan, CROW, Thomas, GUNNING, Tom, HOLLY, Michael Ann, JAY, Martin, KAUFMANN, Thomas Dacosta, KOLBOWSKI, Silvia, LAVIN, Sylvia, MELVILLE, Stephen, MOLESWORTH, Helen, MOXEY, Keith, RODOWICK, D.N., WAITE, Geoff, WOOD, Christopher (1996), 'Visual Culture Questionnaire', *October*, 77, pp. 25-70.
- ANAT, Biletzki and ANAT, Matar (2014), 'Ludwig Wittgenstein', in ZALTA, Edward N. (Ed.), *The Stanford Encyclopedia of Philosophy*, Spring 2014 Edition, Stanford (CA): Stanford University.
- ANDERSON, Priscilla (1999), 'Fifteenth-century bookbinding structure in Italy and the Netherlands. A survey of manuscripts and printed books', *The Book and Paper Group Annual*, 18.
- ARCELLI, C., CORDELLA, L. P., BAJA, G. S. di (Eds.) (1992), *Visual form. Analysis and recognition*, New York (NY); London: Plenum Press.
- ARNHEIM, Rudolf (1969), *Visual thinking*, Berkeley (CA): University of California Press.
- ARNHEIM, Rudolf (1980), 'A plea for visual thinking', *Critical Inquiry*, 6, 3, pp. 489-497.
- ASHER, Nicholas and VIEU, Laure (1995), 'Towards a geometry of common sense. A semantic and complete axiomatization and mereotopology', in *Proceedings of the International Joint Conference on Artificial Intelligence, IJCAI '95*, Montréal: IJCAI, pp. 846-852.
- ATKIN, Albert (2010), 'Peirce's theory of signs', in ZALTA, Edward N. (Ed.), *The Stanford Encyclopedia of Philosophy*, Winter 2010 Edition, Stanford (CA): Stanford University, <http://plato.stanford.edu/archives/win2010/entries/peirce-semiotics> (Accessed 2011-11-11).
- ATTNEAVE, F. (1954), 'Some informational aspects of visual perception', *Psychological Review*, 61, 3, pp. 183-193.
- AURNAGUE, Michel and VIEU, Laure (1993), 'Toward a formal representation of space in language. A commonsense reasoning approach', in *Proceedings of the International Joint Conference on Artificial Intelligence, IJCAI '93*, Chambéry: IJCAI, pp. 123-158.
- BADDELEY, A. (1992), 'Working memory', *Science*, 255, 5044, pp. 556-559.
- BADDELEY, Alan (2000), 'The episodic buffer: a new component of working memory?', *Trends in cognitive sciences*, 4, 11, pp. 417-423.
- BADDELEY, Alan (2003a), 'Working memory and language. An overview', *Journal of Communication Disorders*, 36, 3, pp. 189-208.
- BADDELEY, Alan (2003b), 'Working memory. Looking back and looking forward', *Nature Reviews Neuroscience*, 4, 10, pp. 829-839.

- BADDELEY, Alan D. (2004), 'The psychology of memory', in BADDELEY, Alan D., KOPELMAN, Michael, WILSON, Barbara A. (Eds.), *The Essential Handbook of Memory Disorders for Clinicians*, New York (NY): John Wiley & Sons, pp. 1-13.
- BADDELEY, Alan D. (2007), *Working memory, thought, and action*, Oxford: Oxford University Press.
- BADDELEY, Alan (2013), *Essentials of human memory*, New York (NY), London: Psychology Press.
- BADDELEY, Alan D. and HITCH, Graham J. (1974), 'Working memory', *The psychology of learning and motivation*, 8, pp. 47-89.
- BARKER-PLUMMER, Dave (2002), 'Diagrammatic reasoning', in BARKER-PLUMMER, Dave, BEAVER, David I., BENTHEM, Johan van, SCOTTO DI LUZIO, Patrick (Eds.), *Words, proofs, and diagrams*, Stanford (CA): Center for the Study of Language and Information, pp. 1-4.
- BARKER-PLUMMER, Dave, BEAVER, David I., BENTHEM, Johan van, SCOTTO DI LUZIO, Patrick (Eds.) (2002), *Words, proofs, and diagrams*, Stanford (CA): Center for the Study of Language and Information.
- BARLOW, H.B. and REEVES, B.C. (1979), 'The versatility and absolute efficiency of detecting mirror symmetry in random dot displays', *Vision research*, 19, 7, pp. 783-793.
- BARROW, Harry G. and TENENBAUM, Jay M. (1981), 'Interpreting line drawings as three-dimensional surfaces', *Artificial intelligence*, 17, 1, pp. 75-116.
- BARTHES, Roland (1978), *Image, music, text*, translated by HEATH, Stephen, New York (NY): Hill and Wang.
- BARWISE, Jon and SHIMOIJIMA, Atsushi (1995), 'Surrogate reasoning', *Cognitive Studies: Bulletin of Japanese Cognitive Science Society*, 4, 2, pp. 7-27.
- BENTKOWSKA-KAFEL, Anna, DENARD, Hugh, BAKER, Drew (Eds.) (2012), *Paradata and transparency in virtual heritage* *Digital research in the arts and humanities*, Farnham: Ashgate.
- BENVESTITO, Claudia (2012), 'Cucitura knot-tack: due esempi marcialiani', in BRUSEGAN, Marcello, ELEUTERI, Paolo, FIACCADORI, Gianfranco (Eds.), *San Michele in Isola. Isola della conoscenza. Ottocento anni di storia e cultura camaldolese nella laguna di Venezia. Mostra organizzata in occasione del millenario della fondazione della congregazione camaldolese*, Torino: UTET, pp. 296-298.
- BERTIN, Jacques (1981), *Graphics and Graphic Information Processing*, New York (NY): Walter de Gruyter & Co.
- BERTIN, Jacques (1983/2011), *Semiology of graphics : diagrams, networks, maps*, first English edition with a new epilogue, Redlands (CA): ESRI Press; Distributed by Ingram Publisher Services.

- BHAYRO, S., HAWLEY, R., KESSEL, G., PORMANN, P. E. (2013), 'The Syriac Galen palimpsest. Progress, prospects and problems', *Journal of Semitic Studies*, 58, 1, pp. 131-148.
- BIBLIOTHÈQUE NATIONALE (FRANCE) (1989), *Les tranchefiles brodées: étude historique et technique*, Paris: Bibliothèque Nationale.
- BIEDERMAN, Irving (1985), 'Human image understanding: recent research and a theory', *Computer Vision, Graphics, and Image Processing*, 32, 1, pp. 29-73.
- BIEDERMAN, Irving (1987), 'Recognition-by-components: a theory of human image understanding', *Psychological Review*, 94, pp. 115-147.
- BIEDERMAN, Irving (1995), 'Visual object recognition', in OSHERSON, Daniel N., KOSSLYN, Stephen M., GLEITMAN, Lila R. (Eds.), *An Invitation to Cognitive Science: Visual cognition*, Cambridge (MA): MIT Press, pp. 121-145.
- BIEDERMAN, Irving (2000), 'Recognizing depth-rotated objects: a review of recent research and theory', *Spatial Vision*, 13, 2-3, pp. 2-3.
- BIEDERMAN, Irving and GERHARDSTEIN, Peter C. (1993), 'Recognising depth rotated objects: evidence and conditions for three-dimensional viewpoint in variance', *Journal of Experimental Psychology: Human perception and performance*, 19, pp. 1162-1182.
- BIEDERMAN, Irving and JU, G. (1988), 'Surface versus edge-based determinants of visual recognition', *Cognitive Psychology*, 20, 1, pp. 38-64.
- BIGGS, Michael A. R. (2004), 'Visualisation and Wittgenstein's "Tractatus"', in MALCOLM, M. (Ed.), *Multidisciplinary approaches to visual representations and interpretations*, Amsterdam: Elsevier, pp. 293-303.
- BIJL, Aart (1986), 'Designing with words and pictures in a logic modelling environment', in *Computer-Aided Architecture Design Futures Proceedings, International Conference on Computer-Aided Architectural Design*, Delft: ICCAAD, pp. 128-145.
- BOBICK, Aaron F. (1987), *Natural object categorization*, Cambridge (MA): MIT Artificial Intelligence Laboratory, <http://dspace.mit.edu/handle/1721.1/6964> (Accessed 2011-11-28).
- BOGGESESS, Lois Carolyn (1978), *Computational interpretation of English spatial prepositions*, PhD Thesis, University of Illinois at Urbana-Champaign, Champaign (IL).
- BOGGESESS, Lois Carolyn (1979), *Computational interpretation English spatial prepositions*, Ft. Belvoir (VA): Defense Technical Information Center.
- BOLTER, Jay David and GRUSIN, Richard (2000), *Remediation: Understanding New Media*, 1st, Cambridge, MA: The MIT Press.

- BOR, Daniel (2012), *The ravenous brain: how the new science of consciousness explains our insatiable search for meaning*, New York (NY): Basic Books.
- BORILLO, Mario and GOULETTE, Jean-Pierre (2006), 'Computing architectural composition from the semantics of the 'Vocabulaire de l'architecture'', *Image, Journal of Interdisciplinary Image Science*, July.
- BOSCH, Gulnar K, CARSWELL, John, PETHERBRIDGE, Guy (1981), *Islamic Bindings and Bookmaking: A Catalogue of an Exhibition, May 18, - August 18, 1981*, Chicago: Oriental Institute, University of Chicago.
- BOSSCHE, Piet Vanden, SEGERS, Norbert, WAGEMANS, Johan, d'YDEWALLE, Géry (1992), 'Human perception of affine equivalent polygons', in ARCELLI, Carlo, CORDELLA, Luigi P., BAJA, Gabriella Sanniti di (Eds.), *Visual Form*, New York (NY), London: Plenum Press, pp. 583-592.
- BOUDALIS, Georgios (2007), 'Endbands in Greek-style bindings', *The Paper Conservator*, 31, 1, pp. 29-49.
- BOUKHELIFA, Nadia, BEZERIANOS, Anastasia, ISENBERG, Tobias, FEKETE, Jean-Daniel (2012), 'Evaluating sketchy lines for the visualization of qualitative uncertainty', *IEEE Transactions on Visualization and Computer Graphics*, 18, 12, pp. 2769-2778.
- BOWERS, Fredson (1949/1994), *Principles of bibliographical description*, Winchester; New Castle (DE): St. Paul's Bibliographies; Oak Knoll Press.
- BRACHMAN, Ronald J. and LEVESQUE, Hector J. (2004), *Knowledge representation and reasoning [electronic resource]*, Amsterdam ; Boston (MA): Morgan Kaufmann.
- BRANDIMONTE, Maria A. and GERBINO, Walter (1996), 'When imagery fails: effects of verbal recoding on accessibility of visual memories', in *Stretching the imagination: representation and transformation in mental imagery*, Oxford; New York (NY): Oxford University Press, pp. 31-76.
- BRANDIMONTE, Maria A., HITCH, Graham J., BISHOP, Dorothy V. (1992a), 'Influence of short-term memory codes on visual image processing: evidence from image transformation tasks', *Journal of experimental psychology: learning, memory and cognition*, 18, 1, pp. 157-165.
- BRANDIMONTE, Maria A., HITCH, Graham J., BISHOP, Dorothy V. (1992b), 'Verbal recoding of visual stimuli impairs mental image transformations', *Memory and Cognition*, 20, 4, pp. 449-455.
- BRAY, Dirk de (1607-1658), *Mensen en twee honden in een boekenwinkel (People and two dogs in a book shop)*, <http://www.rijksmuseum.nl/collectie/zoeken/asset.jsp?id=RP-T-1884-A-290> (Accessed 2011-12-26).
- BRAY, Dirk de (1658/1977), *A short instruction in the binding of books*, Amsterdam: Nico Israel.

- BRAY, Tim, PAOLI, Jean, SPERBERG-McQUEEN, C.M., MALER, Eve, YERGAU, François (Eds.) (2008), *Extensible Markup Language (XML) Version 1.0 (Fifth edition)*, <http://www.w3.org/TR/xml/> (Accessed 2014-03-22).
- BRESLAUER, B. H. (1986), *The Uses of Bookbinding Literature* Book Arts Press occasional publications, New York: Book Arts Press, School of Library Service, Columbia University.
- BRITISH CENSUS PROJECT (1990), *A guide to the census of western medieval bookbinding structures to 1500 in British libraries*, [s.l.]: [s.n.].
- BRODLIE, Ken, ALLENDES OSORIO, Rodolfo, LOPES, Adriano (2012), 'A review of uncertainty in data visualization', in DILL, J., EARNSHAW, R., KASIK, D., VINCE, J., WONG, P. C. (Eds.), *Expanding the Frontiers of Visual Analytics and Visualization*, London: Springer-Verlag, pp. 81-109.
- BRODRIBB, Conant (1970), *Drawing archaeological finds for publication*, London: John Baker.
- BROWN, Charity, GEHRKE, Jürgen, LLOYD-JONES, Toby J. (2010), 'A visual and semantic locus to beneficial effects of verbalization on face memory', *The American journal of psychology*, 123, 1, pp. 51-69.
- BRYSON, Norman (1991), 'Semiology and visual interpretation', in BRYSON, Norman, HOLLY, Michael Ann, MOXEY, Keith P.F. (Eds.), *Visual theory: painting and interpretation*, New York (NY): HarperCollins, pp. 61-73.
- BURCH, Robert (2010), 'Charles Sanders Peirce', in ZALTA, Edward N. (Ed.), *The Stanford Encyclopedia of Philosophy*, Fall 2010 Edition, Stanford (CA): Stanford University, <http://plato.stanford.edu/archives/fall2010/entries/peirce> (Accessed 2011-11-11).
- BURKS, Arthur W. (1949), 'Icon, index, and symbol', *Philosophy and Phenomenological Research*, 9, 4, pp. 673-689.
- CAMPAGNOLO, Alberto (2014a), 'Errata (per oculos) corrige. Visual identification of meaningless data in database records of bookbinding structures', in *Care and conservation of manuscripts 15: proceedings of the fifteenth international seminar held at the University of Copenhagen, 2nd-4th April 2014*, (in press), University of Copenhagen and the Royal Library of Denmark: Museum Tusulanum Press; University of Copenhagen.
- CAMPAGNOLO, Alberto (2014b), 'La descrizione delle legature. Descrizioni e generazione automatizzata di diagrammi di strutture di legature storiche', *Kermes: la rivista del restauro*, 92, pp. 18-20.
- CAMPAGNOLO, Alberto and VELIOS, Athanasios (2013), 'Bindings of uncertainty. Visualizing uncertain and imprecise data in automatically generated bookbinding structure diagrams', in *Digital Humanities 2013, conference abstracts, Digital Humanities 2013, the 24th joint international conference of the Association for Literary and Linguistic Computing and Association for Computers and the Humanities and the 5th joint international conference of the Alliance of*



- Digital Humanities Organizations, Conference Abstracts, University of Nebraska-Lincoln, 16-19 July 2013*, University of Nebraska-Lincoln (NE): Center for Digital Research in the Humanities, pp. 135-138.
- CARMICHAEL, L., HOGAN, H.P., WALTER, A.A. (1932), 'An experimental study of the effect of language on the reproduction of visually perceived form', *Journal of Experimental Psychology*, 15, 1, pp. 73-86.
- CARVIN, Denis (1988), *La reliure médiévale du XIVème et XVème siècles: d'après les fonds des bibliothèques d'Aix-en-Provence, Avignon, Carpentras et Marseille*, Arles: Centre Interrégional de Conservation des Livres.
- CASSIODORUS (1961), *Cassiodori Senatoris Institutiones*, Oxford: Clarendon Press.
- CASTELLANI, ENRICO (1920), *La legatura dei codici copti*, unpublished in Henri Hyvernat files: MC VIII.A.3, Roma.
- CAVE, Carolyn B. and KOSSLYN, Stephen M. (1993), 'The role of parts and spatial relations in object identification', *Perception*, 22, 2, pp. 229-248.
- CHASE, William G. and SIMON, Herbert A. (1973), 'Perception in chess', *Cognitive Psychology*, 4, 1, pp. 55-81.
- CHOMSKY, Noam (1957), *Syntactic structures* *Janua linguarum*, The Hague, Paris: Mouton.
- CLARK, James (1999), *XSL Transformations (XSLT) Version 1.0*, <http://www.w3.org/TR/xslt> (Accessed 2014-03-22).
- CLARKSON, Christopher (1978), 'The Conservation of Early Books in Codex Form: A Personal Approach', *The Paper Conservator*, 3, 1, pp. 33-50.
- CLARKSON, Christopher (1993), 'English monastic bookbinding in the twelfth century', in MANIACI, Marilena and MUNAFÒ, Paola F. (Eds.), *Ancient and medieval book materials and techniques: Erice, 18-25 September 1992*, Città del Vaticano: Biblioteca apostolica vaticana, pp. 181-200.
- CLARKSON, Christopher (1996), 'A hitherto unrecorded English Romanesque book sewing technique', in SHARPE, John L (Ed.), *Roger Powell, the complete binder: Liber Amicorum*, Turnhout: Brepols, pp. 215-239.
- CLARKSON, Christopher (1998), 'Some representations of the book and book-making, from the earliest codex forms to Jost Amman.', in SHARPE, John Lawrence and VAN KAMPEN, Kimberly (Eds.), *The Bible as book: the manuscript tradition*, London; New Castle (DE): British Library; Oak Knoll Press, in association with the Scriptorium, Center for Christian Antiquities, pp. 197-203.

- CLARKSON, Christopher (2005), *Limp vellum binding and its potential as a conservation type structure for the rebinding of early printed books: a break with nineteenth and twentieth century rebinding attitudes and practices*, Reprinted with a new introduction and corrections, Oxford: Christopher Clarkson.
- CLAUDE-LACHENAUD, Coline, CHARTON, Eric, OZELL, Benoît, GAGNON, Michel (2014), 'A multimodal interpreter for 3D visualization and animation of verbal concepts', in *Ninth International Conference on Language Resources and Evaluation, LREC 2014*, Reykjavik: European Language Resources Association, pp. 3620-3627.
- CLOONAN, Michèle V. (1984), 'Bookbinding terminology and descriptive bibliography: an analysis of sources', *The New Bookbinder*, 4, pp. 28-33.
- CLOWES, M.B. (1971), 'On seeing things', *Artificial Intelligence*, 2, 1, pp. 79-116.
- COCKERELL, Douglas (1953), *Bookbinding and the care of books: a text-book for bookbinders and librarians*, fifth edition, with drawings by Noel Rooke and other illustrations, London: Sir Isaac Pitman and Sons Ltd..
- COCKERELL, Sydney Morris (1958), *The repairing of books*, with illustrations by Joan Rix Tebbutt, London: Sheppard Press.
- COHEN, Henri and LEFEBVRE, Claire (2005), *Handbook of categorization in cognitive science*, Amsterdam: Elsevier.
- CONN, Donia and VERHEYEN, Peter (2003a), 'A selected bibliography of historic endbands', in *Standards, Seminar on Standards of Excellence in Hand Bookbinding*, Denver (CO): Guild of book workers.
- CONN, Donia and VERHEYEN, Peter (2003b), 'Foundational endband', in *Standards, Seminar on Standards of Excellence in Hand Bookbinding*, Denver (CO): Guild of book workers.
- COOK, Jill (2013), *Ice Age art: the arrival of the modern mind*, London: British Museum Press.
- CORNOLDI, Cesare and LOGIE, Robert (1996), 'Counterpoints in perception and mental imagery: introduction', in *Stretching the imagination: representation and transformation in mental imagery*, Oxford; New York (NY): Oxford University Press, pp. 3-30.
- COWAN, N (2001), 'The magical number 4 in short-term memory: a reconsideration of mental storage capacity', *The behavioral and brain sciences*, 24, 1, pp. 87-185.
- COYNE, Richard D., ROSEMAN, M. A., RADFORD, A. D., BALACHANDRAN, M., GERO, John S. (1990), *Knowledge-based design systems*, edited by COYNE, Richard D., Reading (MA): Addison-Wesley.

- COYNE, Bob and SPROAT, Richard (2001), 'WordsEye. An automatic text-to-scene conversion system', in *Proceedings of the 28th annual conference on Computer graphics and interactive techniques, SIGGRAPH '01*, Los Angeles (CA): ACM, pp. 487-496.
- DAHLSTRÖM, Erik, DENGLER, Patrick, GRASSO, Anthony, LILLEY, Chris, McCORMACK, Cameron, SCHEPERS, Doug, WATT, Jonathan, FERRAILOLO, Jon, FUJISAWA, Jun (Eds.) (2011), *Scalable Vector Graphics (SVG) 1.1 (Second Edition)*, <http://www.w3.org/TR/SVG11/> (Accessed 2014-03-22).
- DARVAS, György (2007), *Symmetry: cultural-historical and ontological aspects of science-arts relations. The natural and man-made world in an interdisciplinary approach*, Basel: Birkhäuser Verlag.
- DAVIS, Daniel (2013), *Modelled on Software Engineering: Flexible Parametric Models in the Practice of Architecture*, PhD Thesis, School of Architecture and Design College of Design and Social context, RMIT University, Melbourne, [http://www.danieldavis.com/papers/danieldavis\\_thesis.pdf](http://www.danieldavis.com/papers/danieldavis_thesis.pdf) (Accessed 2015-04-25).
- DE LUCA, Livio (2013), '3D modelling and semantic enrichment in cultural heritage', in FRITSCH, Dieter (Ed.), *Photogrammetric week 2013, 53<sup>rd</sup> Photogrammetric week*, Stuttgart: Institut für Photogrammetrie, pp. 323-333.
- DE LUCA, Livio, VÉRON, Philippe, FLORENZANO, Michel (2005), 'Semantic-based modelling and representation of patrimony buildings', in *Proceedings of the Workshop towards Semantic Virtual Environments, SVE Workshop 2005*, Villars: MIRAlab, University of Geneva and CUSO.
- DEHAENE, Stanislas (2009), *Reading in the brain: the science and evolution of a human invention*, New York (NY); London: Viking.
- DENNISON, Lynda (1990), 'Oxford, Exeter College MS 47. The importance of stylistic and codicological analysis in its dating and localization', in *Medieval book production, assessing the evicence. Proceedings of the 2nd conference of the Seminar in the History of the Book to 1500, Oxford, July 1988*, Los Altos Hills (CA); London: Anderson-Lovelace; Red Gull Press, pp. 41-59.
- DESCARTES, René (1637/1985), *The philosophical writings of Descartes*, translated by COTTINGHAM, John, STOOTHOFF, Robert, MURDOCH, Dugald, Cambridge; New York (NY): Cambridge University Press.
- DEWEY, John (1946), 'Peirce's theory of linguistic signs, thought, and meaning', *The Journal of Philosophy*, 43, 4, pp. 85-95.
- DJURCILOV, S., KIM, K., LERMUSIAUX, P., PANG, A. (2001), 'Volume rendering data with uncertainty information', in EBERT, D., FAVRE, J. M., PEIKERT, R. (Eds.), *Data visualization*, New York (NY): Springer-Verlag, pp. 243-252.

- DOERR, Martin, PLEXOUSAKIS, Dimitris, BEKIARI, Chryssoyla (2001), 'A metamodel for part-whole relationships for reasoning on missing parts and reconstruction', in KUNII, Hideko S., JAJODIA, Sushil, SØLVBERG, Arne (Eds.), *Conceptual Modeling — ER 2001*, Berlin; Heidelberg: Springer-Verlag, pp. 412-425.
- DONALD, Merlin (1991), *Origins of the modern mind: three stages in the evolution of culture and cognition*, Cambridge (MA): Harvard University Press.
- DONALD, Merlin (2001), *A mind so rare: the evolution of human consciousness*, New York (NY): Norton.
- DONDIS, Donis A. (1973), *Primer of Visual Literacy*, Cambridge (MA): MIT Press.
- DORRESSE, Jean (1949), 'Nouveaux documents gnostiques coptes découverts en Haute-Égypte', *Comptes rendus des séances de l'Académie des Inscriptions et Belles-Lettres*, 93, 2, pp. 176-180.
- DORRESSE, Jean (1961), 'Les Reliures des manuscrits gnostiques coptes découverts à Khéoboskion', *Revue d'Égyptologie*, 13, pp. 27-49.
- DORRESSE, Jean and MINA, Togo (1949), 'Nouveaux textes gnostiques coptes découverts en Haute-Egypte. La bibliotheque de Chenoboskion', *Vigiliae Christianae*, 3, 3, pp. 129-141.
- DORSEY, Jim (1989), 'Techniques: knot-tack sewing in the 15th century', *Binders' Guild Newsletter*, XII, 6, pp. 7-13.
- DRAP, Pierre, MERAD, Djamal, SEINTURIER, Julien, BOÏ, Jean-Marc, PELOSO, Daniela, VANNINI, Guido, NUCCIOTTI, Michele, PRUNO, Elisa (2012), 'An information system for medieval archaeology based on photogrammetry and archaeological database: the Shawbak Castle Project', in IOANNIDES, Marinos, FRITSCH, Dieter, LEISSNER, Johanna, DAVIES, Rob, REMONDINO, Fabio, CAFFO, Rossella (Eds.), *Progress in Cultural Heritage Preservation: 4th International Conference, EuroMed 2012 : Limassol, Cyprus, October 29-November 3, 2012 : Proceedings*, Berlin, Heidelberg: Springer-Verlag, pp. 119-128.
- DYLLA, Kimberly, FRISCHER, Bernard, MUELLER, Pascal, ULMER, Andreas, HAEGLER, Simon (2010), 'Rome reborn 2.0. A case study of virtual city reconstruction using procedural modeling techniques', in FRISCHER, Bernard, WEBB, J., KOLLER, D. (Eds.), *Making History Interactive. Computer Applications and Quantitative Methods in Archaeology (CAA). Proceedings of the 37th International Conference, Williamsburg, Virginia, United States of America, March 22-26 (BAR International Series S2079), CAA 2009*, Oxford: Archeopress, pp. 62-66.
- Eco, Umberto (1975/2008), *Trattato di semiotica generale*, Milano: Bompiani.
- Eco, Umberto (1979), *The Role of the reader: explorations in the semiotics of texts*, Bloomington (IN): Indiana University Press.
- Eco, Umberto (1993), *La ricerca della lingua perfetta nella cultura europea*, Bari; Roma: Laterza.

Eco, Umberto (1997), *Kant e l'ornitorinco*, Milano: Bompiani.

EIDE, Øyvind (2012b), 'Underspecified, ambiguous or formal. Problems in creating maps based on texts', in MEISTER, Jan Christoph (Ed.), *Digital Humanities 2012, 24th joint international conference of the Association for Literary and Linguistic Computing and the Association for Computers and the Humanities and 5th joint international conference of the Association for Literary and Linguistic Computing, the Association for Computers and the Humanities, the Society for Digital Humanities – Société pour l'étude des médias interactifs, together with the Australasian Association for Digital Humanities and centerNet, Conference Abstracts, University of Hamburg, Germany, 16-22 July 2012, Digital Humanities 2012*, University of Hamburg, Germany: Hamburg University Press, Publishing House of the Hamburg State and University Library Carl von Ossietzky, pp. 185-187.

EIDE, Øyvind (2012a), *The area told as a story: an inquiry into the relationship between verbal and map-based expressions of geographical information*, PhD Thesis, King's College London, London.

EIDE, Øyvind (2013), 'Why maps are silent when texts can speak. Detecting media differences through conceptual modelling', in BUCHROITHNER, Manfred F., PRECHTEL, Nikolas, BURGHARDT, Dirk, PIPPING, Karsten, SCHRÖTER, Benjamin (Eds.), *From pole to pole. Proceedings of the 26th International Cartographic Conference, Dresden, 25-30 August 2013, ICC 2013*, Dresden: International Cartographic Association, pp. 674-684.

EIDE, Øyvind (2014), 'Verbal expressions of geographical information', in BARKER, Elton, BOUZAROVSKI, Stefan, PELLING, Chris, ISAKSEN, Leif (Eds.), *New worlds out of old texts. Developing techniques for the spatial analysis of ancient narratives*, in print, Oxford: Oxford University Press.

EITELJORG, Harrison II (2004), 'Computing for archaeologists', in SCHREIBMAN, Susan, SIEMENS, Ray, UNSWORTH, John (Eds.), *A companion to digital humanities*, Oxford: Blackwell Publishing Ltd, pp. 20-30.

ELLESTRÖM, Lars (2010), 'The modalities of media. A model for understanding intermedial relations', in ELLESTRÖM, Lars (Ed.), *Media borders, multimodality and intermediality*, Houndmills, Basingstoke, Hampshire; New York (NY): Palgrave Macmillan, pp. 11-48.

EMERY, Doug, PORTER, Dot, CAMPAGNOLO, Alberto (2014), 'Taking manuscripts apart, and putting them together', in *Digital Humanities 2014, the 25th joint international conference of the Association for Literary and Linguistic Computing and Association for Computers and the Humanities and the 6th joint international conference of the Alliance of Digital Humanities Organizations, Conference Abstracts, EPFL-UNIL University of Lausanne, 7-12 July 2014, Digital Humanities 2014*, University of Lausanne: EPFL-UNIL University of Lausanne, pp. 458-459.

ENCYCLOPÆDIA BRITANNICA (1911), *Torus*, [http://en.wikisource.org/wiki/1911\\_Encyclop%C3%A6dia\\_Britannica/Torus](http://en.wikisource.org/wiki/1911_Encyclop%C3%A6dia_Britannica/Torus) (Accessed 2014-09-05 10:39:32).

- ERICSSON, K. Anders and MOXLEY, Jerad H. (2012), 'Working memory that mediates experts' performance. Why it is qualitatively different from traditional working memory', in ALLOWAY, Tracy P. and ALLOWAY, Ross G. (Eds.), *Working memory: the connected intelligence*, New York (NY); London: Psychology Press, pp. 109-136.
- ETEMAD, Elika J. (2011), *Cascading Style Sheets (CSS) Snapshot 2010*, <http://www.w3.org/TR/css-2010/> (Accessed 2015-05-05).
- FEDERICI, Carlo, CARVIN, Denis, HOULIS, Konstantinos, PASCALICCHIO, Francesca (1988), *Scheda di censimento delle legature medievali: protocollo di descrizione*, Roma: Enidata, Istituto Centrale per la Patologia del Libro.
- FEDERICI, Carlo and HOULIS, Kostantinos (1988), *Legature bizantine vaticane*, Roma: Fratelli Palombi.
- FEDERICI, Carlo and PASCALICCHIO, Francesca (1993), 'A census of medieval bookbindings: early examples', in MANIACI, Marilena and MUNAFÒ, Paola F (Eds.), *Ancient and medieval book materials and techniques: Erice, 18-25 September 1992*, Città del Vaticano: Biblioteca apostolica vaticana, pp. 181-200.
- FELDMAN, Jacob (1997), 'The structure of perceptual categories', *Journal of Mathematical Psychology*, 41, 2, pp. 145-170.
- FELDMAN, Jacob (2000), 'Bias toward regular form in mental shape spaces', *Journal of Experimental Psychology: Human Perception and Performance*, 26, 1, pp. 152-165.
- FERGUSON, Eugene S. (1992), *Engineering and the mind's eye*, Cambridge (MA): MIT Press,.
- FERGUSON, Benjamin (2013), *The representation of logical form: a dilemma*, <http://benjaminferguson.org/wp-content/uploads/2013/01/PH501-Saying-and-Showing-Paper.pdf> (Accessed 2014-05-30).
- FERRIER, Gillian Maver (1996), *A geometry without angles. The case for a functional geometry of spatial prepositions*, PhD Thesis, University of Glasgow, , <http://theses.gla.ac.uk/2045/> (Accessed 2014-09-07 08:42:11).
- FINDLAY, John M. and GILCHRIST, Iain D. (2003), *Active vision: the psychology of looking and seeing*, Oxford; New York (NY): Oxford University Press.
- FINDLAY, John M. and GILCHRIST, Iain D. (2005), 'Eye guidance and visual search', in UNDERWOOD, G. (Ed.), *Cognitive Processes in Eye Guidance*, Oxford: Oxford University Press, pp. 259-281.
- FINDLER, N. V. (1979), *Associative networks. Representation and use of knowledge by computers*, New York (NY): Academic Press.
- FINE, Kit (1999), 'Things and their parts', *Midwest Studies in Philosophy*, 23, 1, pp. 61-74.

- FISCHER, Barbara (1994), 'Old books: structural elements of their bindings. A survey', in DI FEBBO, Assunta, PUTTI, Maria Letizia, ISTITUTO CENTRALE DI PATOLOGIA DEL LIBRO (ROME) (Eds.), *Bollettino dell'Istituto Centrale per la Patologia del Libro, 1990-1991, La legatura dei libri antichi tra conoscenza, valorizzazione e tutela : convegno internazionale, Parma, 16-18 novembre 1989*, Parma: Istituto centrale per la patologia dei libro, pp. 251-262.
- FISCHER, Steven Roger (2005), *A History of Writing*, London: Reaktion Books.
- FISH, Max H. (1978), 'Peirce's general theory of signs', in SEBOEK, T.A. (Ed.), *Sight, sound, and sense*, Bloomington (IN): Indiana University Press, pp. 31-70.
- FISLER, Kathi (2002), 'Diagrams and computational efficacy', in BARKER-PLUMMER, Dave, BEAVER, David I., BENTHEM, Johan van, SCOTTO DI LUZIO, Patrick (Eds.), *Words, proofs, and diagrams*, Stanford (CA): Center for the Study of Language and Information, pp. 27-46.
- FOOT, Mirjam (1993), 'Bookbinding and the History of Books', in BARKER, Nicolas (Ed.), *A Potencie of Life: Books in Society: The Clark Lectures 1986-1987*, London: British Library, pp. 113-126.
- FOOT, Mirjam (2004), 'Bookbinding research: pitfalls, possibilities and needs', in RANDEIRA, Phiroze and FOOT, Mirjam (Eds.), *Eloquent witnesses: bookbindings and their history, a volume of essays dedicated to the memory of Dr. Phiroze Randeria*, London; New Castle (DE): Bibliographical Society; British Library; Oak Knoll Press, pp. 13-29.
- FORD, David (1993), 'The nature of clarity in archaeological line drawings', *Journal of Field Archaeology*, 20, 3, pp. 319-333.
- FORREST, Peter (2012), 'The identity of indiscernibles', in ZALTA, Edward N. (Ed.), *The Stanford Encyclopedia of Philosophy*, Winter 2012 Edition, Stanford (CA): Stanford University, <http://plato.stanford.edu/archives/win2012/entries/identity-indiscernible> (Accessed 2013-01-03).
- FREUDENBERG, Bert, MASUCH, Maic, RÖBER, Niklas, STROTHOTTE, Thomas (2001), 'The Computer-Visualistik-Raum. Veritable and inexpensive presentation of a virtual reconstruction', in *Proceedings of the 2001 Conference on Virtual Reality, Archeology, and Cultural Heritage*, New York (NY): ACM, pp. 97-102.
- FREYD, J. and TVERSKY, Barbara (1984), 'Force of symmetry in form perception', *The American Journal of Psychology*, 97, 1, pp. 109-126.
- GABBAY, DOV M. and SMETS, Philippe (1998), *Quantified representation of uncertainty and imprecision*, New York (NY): Springer.
- GARNER, Wendell R. (1974), *The processing of information and structure*, Potomac (MD): L. Erlbaum Associates; distributed by Halsted Press New York.
- GARROD, SIMON, FERRIER, Gillian, CAMPBELL, Siobhan (1999), 'IN and ON. Investigating the functional geometry of spatial prepositions', *Cognition*, 72, 2, pp. 167-189.

- GARRONI, Emilio (1972), *Progetto di semiotica: messaggi artistici e linguaggi non-verbali, problemi teorici e applicativi*, Bari: Laterza.
- GASKELL, Philip (1972), *A New Introduction to Bibliography*, Oxford: Clarendon Press.
- GAUTHIER, Isabel, JAMES, Thomas W., CURBY, Kim M., TARR, Michael J. (2003), 'The influence of conceptual knowledge on visual discrimination', *Cognitive neuropsychology*, 20, 3, pp. 507-523.
- GEERTZ, Clifford (1973), *The interpretation of cultures. Selected essays*, New York: Basic Books.
- GETHIN POWELL, Rees (2012), 'Uncertain date, uncertain place. Interpreting the history of Jewish communities in the Byzantine empire using GIS', in MEISTER, Jan Christoph (Ed.), *Digital Humanities 2012, conference abstracts, Digital Humanities 2012, 24th joint international conference of the Association for Literary and Linguistic Computing and the Association for Computers and the Humanities and 5th joint international conference of the Association for Literary and Linguistic Computing, the Association for Computers and the Humanities, the Society for Digital Humanities - Société pour l'étude des médias interactifs, together with the Australasian Association for Digital Humanities and centerNet, Conference Abstracts, University of Hamburg, Germany, 16-22 July 2012*, University of Hamburg, Germany: Hamburg University Press, Publishing House of the Hamburg State and University Library Carl von Ossietzky, pp. 329-331.
- GNIRREP, Kees, GUMBERT, J.P., SZIRMAI, János A. (1992), *Kneep en binding: een terminologie voor de beschrijving van de constructies van oude boekbanden*, Den Haag: Koninklijke Bibliotheek.
- GNOLI, Claudio (2008), 'L'organizzazione della conoscenza e i suoi fondamenti', in GNOLI, Claudio and SCOGNAMIGLIO, Carlo (Eds.), *Ontologia e organizzazione della conoscenza. Introduzioni ai fondamenti teorici dell'indicizzazione semantica*, Lecce: Pensa Multimedia, pp. 69-137.
- GOBET, Fernand and CLARKSON, Gary (2004), 'Chunks in expert memory: evidence for the magical number four ... or is it two?', *Memory*, 12, 6, pp. 732-747.
- GOLDMEIER, Erich (1972), *Similarity in visually perceived forms*, Madison (CT): International Universities Press.
- GOLDSCHMIDT, Ernst P. (1928), *Gothic and Renaissance bookbindings: exemplified and illustrated from the author's collection*, London; Boston: E. Benn; Houghton Mifflin Co.
- GOLDSCHMIDT, Ernst P. (1945), 'The study of early bookbinding', in *The Bibliographical Society, 1892-1942: studies in retrospect*, London: Printed for the Bibliographical Society, pp. 175-184.
- GOODCHILD, M., BUTTENFIELD, B., WOOD, J. (1994), 'On introduction to visualizing data validity', in HEARNSHAW, H. M. and UNWIN, D. J. (Eds.), *Visualization in geographical information systems*, New York (NY): Wiley, pp. 141-149.
- GOODMAN, Nelson (1976), *Languages of art: an approach to a theory of symbols*, Indianapolis (IN); Cambridge (MA): Hackett Publishing Co, Inc.



- GORLÉE, Dinda L. (1989), 'Wittgenstein, Translation, and Semiotics', *Target*, 1, 1, pp. 69-94.
- GOTTWALD, Siegfried and ANAT, Matar (2014), 'Many-valued logic', in ZALTA, Edward N. (Ed.), *The Stanford Encyclopedia of Philosophy*, Spring 2014 Edition, Stanford (CA): Stanford University.
- GOULETTE, Jean-Pierre (1999), 'Sémantique formelle de l'espace. Une application au raisonnement spatial qualitatif en architecture', *Revue intellectuelle*, 2, 29, pp. 9-34.
- GREAVES, Mark Thomas (2002), *The philosophical status of diagrams*, Stanford (CA): Center for the Study of Language and Information.
- GREENFIELD, Jane (1990), *Headbands: how to work them*, second revised edition, New Castle (DE): Oak Knoll Books.
- GREENFIELD, Jane (1998), *ABC of bookbinding: a unique glossary with over 700 illustrations for collectors & librarians*, New Castle (DE); New York (NY): Oak Knoll Press; Lyons Press.
- GREENLEE, Douglas (1973), *Peirce's concept of sign*, The Hague: Mouton.
- GRIETHE, Henning and SCHUMANN, Heidrun (2006), 'The visualization of uncertain data. Methods and problems', in *Proceedings of the 17th Simulation and Visualization Conference*, Aarhus: Interaction Design Foundation, pp. 143-156.
- GRIFFITHS, N., JENNER, Anne, WILSON, Christine (1990), *Drawing archaeological finds: a handbook*, Revised edition, London: Archetype Publications Ltd.
- GROSDIDIER DE MATONS, Dominique, HOFFMANN, Philippe, VEZIN, Jean (1993), 'Le recensement des reliure anciennes conservées dans les collections publiques de France: réflexions sur une méthode de travail', in MANIACI, Marilena and MUNAFÒ, Paola F (Eds.), *Ancient and medieval book materials and techniques: Erice, 18-25 September 1992*, Città del Vaticano: Biblioteca apostolica vaticana, pp. 157-179.
- GRUIJS, Albert (1974), 'Le protocole de la restauration et la description des cahiers et bifolia', in *Les techniques de laboratoire dans l'étude des manuscrits : [actes du colloque international] Paris, 13-115 septembre 1972*, Paris: Centre national de la recherche scientifique, pp. 253-255.
- HALVERSON, John (1992), 'The first pictures: perceptual foundations of Paleolithic art', *Perception*, 21, 3, pp. 389-404.
- HAMILTON, Kelly Ann (2001a), 'Some philosophical consequences of Wittgenstein's aeronautical research', *Perspectives on Science*, 9, 1, pp. 1-37.
- HAMILTON, Kelly Ann (2001b), 'Wittgenstein and the Mind's Eye', in *Wittgenstein: biography and philosophy*, Cambridge: Cambridge University Press, pp. 53-97.

- HAMILTON, Kelly Ann (2002), 'Darstellungen in The Principles of Mechanics and the Tractatus: the representation of objects in relation in Hertz and Wittgenstein', *Perspectives on Science*, 10, 1, pp. 28-68.
- HAMILTON, Kelly Ann (2012), 'Wittgenstein and Tufte on thinking in 3D: 'Escaping Flatland'', in *EVA London 2012: electronic visualisation and the arts*, *Electronic visualisation and the arts (EVA 2012)*, London: BCS, The Chartered Institute for IT, pp. 107-118.
- HAMMER, Eric M. (1995), *Logic and visual information*, Stanford (CA): Center for the Study of Language and Information.
- HAMPTON, J.A. (1981), 'An investigation of the nature of abstract concepts', *Memory & Cognition*, 9, 2, pp. 149-156.
- HARRISON, Matthew James, KEAY, Simon, EARL, Greame (2012), 'Shape grammar modelling and the visualisation of an uncertain past', in *CAA2012 Proceeding of the 40th Conference in Computer Application and Quantitative Methods in Archaeology, Southampton, UK, 26-30 March 2012*, CAA 2012, Southampton: CAA, pp. 895-909.
- HARTE, Verity (2002), *Plato on parts and wholes: the metaphysics of structure*, Oxford: Clarendon Press.
- HEILBRONNER, Edgar and DUNITZ, Jack D. (1993), *Reflections on symmetry: in chemistry and elsewhere*, Basel: Wiley-VCH.
- HEISER, Julie and TVERSKY, Barbara (2002), 'Diagrams and descriptions in acquiring complex systems', in GRAY, Wayne and SCHUNN, Christian D. (Eds.), *Proceedings of the meetings of Cognitive Science Society, Twenty-Fourth Annual CSS Conference, George Mason University in Fairfax Virginia, USA, August 7-10, 2002*, Fort Belvoir (VA): Defense Technical Information Center, pp. 447-452.
- HEISER, Julie and TVERSKY, Barbara (2006), 'Arrows in comprehending and producing mechanical diagrams', *Cognitive Science*, 30, 3, pp. 581-592.
- HEPTING, Daryl (1999), *The history of a picture's worth*, <http://www2.cs.uregina.ca/~hepting/research/web/words/history.html#27ad> (Accessed 2013-05-26).
- HERSKOVITS, Annette (1980), 'On the spatial uses of prepositions', in *Proceedings of the 18th annual meeting on Association for Computational Linguistics*, Philadelphia (PA): Association for Computational Linguistics, pp. 1-5.
- HETHERINGTON, Robina, FARRIMOND, Brian, PRESLAND, Steve (2006), 'Information rich temporal virtual models using X3D', *Computers & Graphics*, 30, 2, pp. 287-298.
- HINTON, Geoffrey (1979), 'Some Demonstrations of the Effects of Structural Descriptions in Mental Imagery', *Cognitive Science*, 3, 3, pp. 231-250.

- HOCHBERG, Julian (1978), *Perception*, second revised edition, Englewood Cliffs (NJ): Prentice Hall.
- HOCHBERG, Julian and BROOKS, Virginia (1962), 'Pictorial recognition as an unlearned ability: a study of one child's performance', *The American Journal of Psychology*, 75, 4, pp. 624-628.
- HOOPES, James (1991), *Peirce on signs. Writings on semiotic*, Chapel Hill (NC): University of North Carolina Press.
- HORN, Robert E. (1998), *Visual language: global communication for the 21st century*, Bainbridge Island (WA): Macrovue, Inc..
- HOULIS, Konstantinos and PESCALICCHIO, Francesca (1988), *Scheda di censimento delle legature medievali: bordereau*, Roma: Enidata, Istituto Centrale per la Patologia del Libro.
- HOUSECROFT, Catherine and SHARPE, Alan G. (2012), *Inorganic chemistry*, 4<sup>th</sup> edition, Harlow; New York (NY): Prentice Hall.
- HOWARD, Ian P. and TEMPLETON, William Brian (1966), *Human spatial orientation*, London: John Wiley & Sons.
- HUFFMAN, David A. (1971), 'Impossible objects as nonsense sentences', *Machine intelligence*, 6, 1, pp. 295-323.
- HUNT, Leigh (1823), 'Among my books', *Literary Examiner*, 5-12 July, <http://spenserians.cath.vt.edu/TextRecord.php?textsid=36476> (Accessed 2013-06-28).
- ISHIHARA-BRITO, Reiko (2011), *Archaeological Illustration of Ceramics: drawing conventions and practices in the Maya area. Handbook for the 1st annual Maya at the Lago Workshop, April 14-17, 2011*, Washington (DC): Dumbarton Oaks Research Library and Collection.
- IVERSEN, Margaret (1986), 'Saussure versus Peirce: models for a semiotics of visual art', in REES, A.L. and BORZELLO, F. (Eds.), *The new art history*, London: Camden Press, pp. 82-94.
- IVINS, William M. (1953/1969), *Prints and visual communication*, Cambridge (MA): MIT Press.
- IVINS, William M. (1973), *On the rationalization of sight: with an examination of three Renaissance texts on perspective*, New York (NY): Da Capo Press.
- JAKOBSON, Roman (1959), 'On linguistic aspects of translation', in BROWER, R. A. (Ed.), *Translation*, Cambridge (MA): Harvard University Press, pp. 232-239.
- JEMOLO, V. and MORELLI, M. (Eds.) (1990), *Guida a una descrizione uniforme dei manoscritti e al loro censimento*, Roma: Istituto Centrale per il Catalogo Unico.
- JOHANSSON, Richard, BERGLUND, Anders, DANIELSSON, Magnus, NUGUES, Pierre (2005), 'Automatic text-to-scene conversion in the traffic accident domain', in *Proceedings of the Nineteenth*

*International Joint Conference on Artificial Intelligence, Edinburgh, Scotland, UK, July 30-August 5, 2005, IJCAI2005*, Edinburgh: Professional Book Center, pp. 1073-1078.

- JOHANSSON, Richard, WILLIAMS, David, NUGUES, Pierre (2004), 'Converting texts of road accidents into 3D scenes', in LÓPEZ DE MÁNTARAS, R. and SAITTA, L. (Eds.), *Proceedings of the 16th European Conference on Artificial Intelligence, ECAI 2004*, Valencia: IOS Press, pp. 1035-1045.
- JOHNSON, Richard (1994), *Schematic Diagrams*, Chennai (Tamil Nadu, India): Prompt publications.
- JOHNSON, Chris R. and SANDERSON, Allen R. (2003), 'A Next Step: Visualizing Errors and Uncertainty', *IEEE Computer Graphics and Applications*, 23, 5, pp. 6-10.
- JOHNSTON, Mark (2002), 'Parts and principles: false axioms in mereology', *Philosophical Topics*, 30, 1, pp. 129-166.
- JOLICOEUR, Pierre, GLUCK, Mark A., KOSSLYN, Stephen M. (1984), 'Pictures and names: making the connection', *Cognitive psychology*, 16, 2, pp. 243-275.
- JÄCKEL, Von Karl (1974), 'Alte Techniken des Buchbinderhandwerks in der modernen Schriftgutrestaurierung. 1 Das Heften', *Bibliotheksforum Bayern*, 2, 3, pp. 255-264.
- JÄCKEL, Von Karl (1975), 'Alte Techniken des Buchbinderhandwerks in der modernen Schriftgutrestaurierung. 2 Das Kapital', *Bibliotheksforum Bayern*, 3, 3, pp. 207-219.
- JÄCKEL, Von Karl (1977), 'Alte Techniken des Buchbinderhandwerks in der modernen Schriftgutrestaurierung. 3 Der Holzdeckel', *Bibliotheksforum Bayern*, 5, 2, pp. 122-130.
- KENNEDY, John M. (1974), *A psychology of picture perception*, San Francisco (CA): Jossey-Bass Publishers.
- KENNEDY, John M. (1977), 'Ancient and modern picture-perception abilities in Africa', *The Journal of Aesthetics and Art Criticism*, 35, 3 (Spring), pp. 293-300.
- KENNEDY, Maev (2011), 'British Library seeks £9m to buy oldest book in Europe', *The Guardian*, 14 July, <http://www.guardian.co.uk/books/2011/jul/14/british-library-seeks-buy-oldest-book> (Accessed 2013-05-20).
- KENNEDY, John M. and ROSS, Abraham S. (1975), 'Outline picture perception by the Song of Papua', *Perception*, 4, 4, pp. 391-406.
- KIOUSSI, Anastasia, KAROGLU, Maria, BAKOLAS, Asterios, MOROPOULOU, Antonia (2012), 'Integrated documentation protocols enabling decision making in cultural heritage protection', in IOANNIDES, Marinos, FRITSCH, Dieter, LEISSNER, Johanna, DAVIES, Rob, REMONDINO, Fabio, CAFFO, Rossella (Eds.), *Progress in Cultural Heritage Preservation: 4th International Conference, EuroMed 2012 : Limassol, Cyprus, October 29-November 3, 2012 : Proceedings*, Berlin, Heidelberg: Springer-Verlag, pp. 211-220.

- KIRSH, David (2002), 'Why illustrations aid understanding', in PLOETZNER, R. (Ed.), *Proceedings of the international workshop on dynamic visualizations and learning, Tübingen, Germany*, Tübingen: Knowledge Media Research Center, pp. 1-9.
- KITCHER, Patricia (1988), 'Marr's computational theory of vision', *Philosophy of Science*, 55, 1, pp. 1-24.
- KLATZKY, Roberta L., MARTIN, G.L., KANE, R.A. (1982), 'Semantic interpretation effects on memory for faces', *Memory & cognition*, 10, 3, pp. 195-206.
- KLEE, Eleonore (1978), 'Knotenheftung des 15. Jahrhunderts', *Codices manuscripti: Zeitschrift für Handschriftenkunde*, 4, 3, pp. 89-92.
- KOFFKA, Kurt (1935), *Principles of Gestalt psychology*, Oxford: Harcourt Brace.
- KOSLICKI, Kathrin (2007), 'Towards a Neo-Aristotelian mereology', *Dialectica*, 61, pp. 127-159.
- KOSLICKI, Kathrin (2008), *The structure of objects*, Oxford; New York (NY): Oxford University Press.
- KOSSLYN, Stephen M. (1980), *Image and mind*, Cambridge (MA): Harvard University Press.
- KOSSLYN, Stephen M. (1986), *Image and mind*, Cambridge (MA): Harvard University Press.
- KOSSLYN, Stephen M., ALPERT, Nathaniel M., THOMPSON, William L., MALJKOVIC, Vera, WEISE, Steven B., CHABRIS, Christopher F., HAMILTON, Sania E., RAUCH, Scott L., BUONANNO, Ferdinando S. (1993), 'Visual mental imagery activates topographically organized visual cortex: PET investigations', *Journal of Cognitive Neuroscience*, 5, 3, pp. 263-287.
- KOSSLYN, Stephen M. and GANIS, Giorgio (2010), *The case for mental imagery*, Oxford; New York (NY): Oxford University Press.
- KOSSLYN, Stephen M. and THOMPSON, William L. (2003), 'When is early visual cortex activated during visual mental imagery?', *Psychological bulletin*, 129, 5, pp. 723-746.
- KOTIADIS, K. and ROBINSON, S. (2008), 'Conceptual modelling. Knowledge acquisition and model abstraction', in MASON, J.S., HILL, R.R., MÖNCH, M., ROSE, O., JEFFERSON, T., FOWLER, J.W. (Eds.), *Proceedings of the 2008 Winter Simulation Conference, Winter Simulation Conference 2008*, Miami (FL): Institute of Electrical and Electronics Engineers, pp. 951-958.
- KRESS, Gunther (2000), 'Text as the punctuation of semiosis: pulling at some threads', in MEINHOF, Ulrike Hanna and SMITH, Jonathan (Eds.), *Intertextuality and the media: from genre to everyday life*, Manchester; New York (NY): Manchester University Press; St. Martin's Press, pp. 132-154.

- KUBOVY, Michael (1981), 'Concurrent-Pitch Segregation and the Theory of Indispensable Attributes', in KUBOVY, Michael and POMERANTZ, James R (Eds.), *Perceptual organization*, Hillsdale (NJ): Lawrence Erlbaum Associates, pp. 55-98.
- KURATA, Yohei and EGENHOFER, Max J. (2005a), 'Semantics of simple arrow diagrams', in BARKOWSKY, Thomas, FREKSA, Christian, HEGARTY, Mary, LOWE, Ric (Eds.), *Reasoning with mental external diagrams: computational modeling and spatial assistance. Technical report SS-05-06, 2005 AAAI Spring Symposium*, Menlo Park (CA): AAAI Press, pp. 101-104.
- KURATA, Yohei and EGENHOFER, Max J. (2005b), 'Structure and semantics of arrow diagrams', *Lecture notes in computer science, no. 3693*, pp. 232-250.
- KÖHLER, Wolfgang (1929), *Gestalt psychology*, Oxford: Liveright.
- LAKOFF, George P. (1987), *Women, fire and dangerous things: what categories reveal about the mind*, Chicago (IL): University of Chicago Press.
- LATOUR, BRUNO (1986), 'Visualization and cognition: thinking with eyes and hands', *Knowledge and society, studies in the sociology of culture past and present*, 6, 1, pp. 1-40.
- LATTA, Greg ([s.n.]), *The AA8V Twinplex Regenerative Receiver. Schematic diagrams and circuit descriptions*, <http://faculty.frostburg.edu/phys/latta/ee/twinplex/schematic/twinplexschematic.html> (Accessed 2014-09-04).
- LEEUWENBERG, Emanuel Laurens Jan (1968), *Structural information of visual patterns. An efficient coding system in perception*, The Hague, Paris: Mouton.
- LEEUWENBERG, Emanuel Laurens Jan (1969), 'Quantitative specification of information in sequential patterns', *Psychological Review*, 76, 2, pp. 216-220.
- LEEUWENBERG, Emanuel Laurens Jan (1971), 'A Perceptual Coding Language for Visual and Auditory Patterns', *The American Journal of Psychology*, 84, 3, pp. 307-349.
- LEMON, Oliver (2002), 'Comparing the efficacy of visual languages', in BARKER-PLUMMER, Dave, BEAVER, David I., BENTHEM, Johan van, SCOTTO DI LUZIO, Patrick (Eds.), *Words, proofs, and diagrams*, Stanford (CA): Center for the Study of Language and Information, pp. 47-70.
- LEVEY, Martin (1962), *Mediaeval Arabic Bookmaking: And Its Relation to Early Chemistry and Pharmacology [by] Martin Levey* *Transactions of the American Philosophical Society*, Philadelphia: The American Philosophical Society.
- LEWIS, Philippa and DARLEY, Gillian (1986), *Dictionary of ornament*, New York (NY): Pantheon Books.
- LEYTON, Michael (1984), 'Perceptual organization as nested control', *Biological Cybernetics*, 51, 3, pp. 141-153.

- LEYTON, Michael (1986a), 'A theory of information structure I: general principles', *Journal of Mathematical Psychology*, 30, 2, pp. 103-160.
- LEYTON, Michael (1986b), 'A theory of information structure II: a theory of perceptual organization', *Journal of Mathematical Psychology*, 30, 3, pp. 257-305.
- LEYTON, Michael (1987), 'A limitation theorem for the differentiable prototypification of shape', *Journal of Mathematical Psychology*, 31, 4, pp. 307-320.
- LEYTON, Michael (1992), *Symmetry, causality, mind*, Boston (MA): MIT Press.
- LEYTON, Michael (2001), *A generative theory of shape*, Berlin; Heidelberg: Springer.
- LIGATUS (2007), *Survey schemas. Saint Catherine's project*, <http://www.ligatus.org.uk/stcatherine/node/1052> (Accessed 2014-08-22).
- LIGATUS (2013), *Ligatus bookbinding glossary*, <http://www.ligatus.org.uk/glossary/> (Accessed 2013-07-28).
- LILLEY, Chris (1996), *W3C scalable graphics requirements*, <http://www.w3.org/Graphics/Scalable-Req.html> (Accessed 2015-04-25).
- LITTLE, Martha (2010), 'Evidence of structure and procedure in books. Selected examples of potential clues', in *Standards, Seminar on Standards of Excellence in Hand Bookbinding*, Tucson (AZ): Guild of book workers.
- LOCKWOOD, Kate, FORBUS, Ken, HALSTEAD, D., USHER, Jeffrey (2006), 'Automatic categorization of spatial prepositions', in *Proceedings of the 28th annual conference of the Cognitive Science Society, Conference of the cognitive sciences*, Wheat Ridge (CO): Cognitive Science Society, pp. 1705-1710.
- LOPES, Dominic (1996), *Understanding Pictures*, Oxford: Clarendon Press.
- LU, Zhong-Lin and DOSHER, Barbara (2013), *Visual psychophysics. From laboratory to theory*, Cambridge (MA): MIT Press.
- MACEachREN, A. M (1992), 'Visualizing uncertain information', *Cartographic Perspectives*, 13, pp. 10-19.
- MACEachREN, Alan M., ROBINSON, Anthony, GARDNER, Steven, MURRAY, Robert, GAHEGAN, Mark, HETZLER, Elisabeth (2005), 'Visualizing geospatial information uncertainty. What we know and what we need to know', *Cartography and Geography Information Science*, 32, 3, pp. 139-160.
- MACH, Ernst (1897/1959), *The analysis of sensations, and the relation of the physical to the psychical*, New York: Dover Publications.

- MADAN, FALCONER, TURBUTT, Gladwyn, GIBSON, Strickland (1905), *The original Bodleian copy of the first folio of Shakespeare (The Turbutt Shakespeare)*, Oxford: Clarendon Press.
- MALIK, Jitendra (1987), 'Interpreting line drawings of curved objects', *International Journal of Computer Vision*, 1, 1, pp. 73-103.
- MARR, David (1982), *Vision: a computational investigation into the human representation and processing of visual information*, San Francisco (CA): W. H. Freeman & Company.
- MARR, David and NISHIHARA, H.K. (1978a), 'Representation and recognition of the spatial organization of three-dimensional shapes', *Proceedings of the Royal Society of London. Series B, Biological Sciences*, 200, 1140, pp. 269-294.
- MARR, D and NISHIHARA, H K (1978b), 'Representation and recognition of the spatial organization of three-dimensional shapes', *Proceedings of the Royal Society of London. Series B, Containing papers of a Biological character. Royal Society (Great Britain)*, 200, 1140, pp. 269-294.
- MARTENS, Femke, MUŠI, B., POBLOME, Jeroen, WAELEKENS, Marc (2012), 'The integrated urban survey at Sagalassos', in VERMEULEN, Frank, BURGERS, Gert-Jan, KEAY, Simon, CORSI, Cristina (Eds.), *Urban landscape survey in Italy and the Mediterranean*, Oxford: Oxbow Books, pp. 84-93.
- MAURY, André (1983), 'Reality and logical form', *Synthese*, 56, 2, pp. 171-180.
- McCALL, Matthew (2009), 'The points of the picture: Hertz and Wittgenstein on the picture theory', *Papers from the 32nd International Wittgenstein Symposia, Kirchberg am Wechsel*, pp. 269-271.
- McCARTY, Willard (2005), *Humanities computing*, Houndmills, Basingstoke, Hampshire; New York (NY): Palgrave Macmillan.
- McCOLLOUGH, Andrew and VOGEL, Edward (2007), 'Visual chunking allows efficient allocation of memory capacity', *Journal of Vision*, 7, 9, pp. 861-861.
- McKENZIE, Donald F. (1999), *Bibliography and the sociology of texts*, Cambridge; New York (NY): Cambridge University Press.
- McKIE, Robin (2012), 'When Homo sapiens hit upon the power of art', *The Guardian*, 9 December, <http://www.guardian.co.uk/science/2012/dec/09/ice-age-art-exhibition-british-museum> (Accessed 2013-06-05).
- McKITTRICK, David (2007), 'Perspectives for an international history of the book', in ELIOT, Simon, NASH, Andrew, WILLISON, Ian Roy (Eds.), *Literary cultures and the material book*, London: British Library, pp. 413-429.



- McLUHAN, Marshall (1964/2001), *Understanding media: the extensions of man*, London; New York (NY): Routledge.
- McLUHAN, Marshall and POWERS, Bruce R. (1989), *The global village: transformations in world life and media in the 21st century*, Oxford; New York (NY): Oxford University Press.
- MERMET, Jean P. (Ed.) (1993), *Fundamentals and standards in Hardware Description Languages*, Dordrecht; Boston (MA): Kluwer Academic Publishers.
- MERVIS, Carolyn B. and ROSCH, Eleanor (1981), 'Categorization of natural objects', *Annual Review of Psychology*, 32, 1, pp. 89-115.
- MIDDLETON, Bernard C. (1996), *A history of English craft bookbinding technique*, fourth rev. ed., New Castle (DE); London: Oak Knoll Press; British Library.
- MILLER, George (1956), 'The magical number seven, plus or minus two: Some limits on our capacity for processing information', *The psychological review*, 63, pp. 81-97.
- MILLER, George A. (2003), 'The cognitive revolution: a historical perspective', *TRENDS in Cognitive Sciences*, 7, 3, pp. 141-144.
- MILLER, George Armitage and JOHNSON-LAIRD, Philip Nicholas (1976), *Language and perception*, Cambridge (MA): Belknap Press of Harvard University Press.
- MILLER, P. and RICHARDS, J. (1995), 'The good, the bad and the downright misleading. Archaeological adoption of computer visualization', in HUGGET, J. and RYAN, N. (Eds.), *Computer Applications and Quantitative Methods in Archaeology, Glasgow, 1994, CAA1994*, Oxford: Tempus Reparatum, pp. 249-254.
- MITCHELL, William J.T. (1980), *The Language of images*, Chicago (IL): University of Chicago Press.
- MITCHELL, William J.T. (1986), *Iconology: image, text, ideology*, Chicago (IL); London: University of Chicago Press.
- MITCHELL, William J.T. (1994), *Picture theory: essays on verbal and visual representation*, Chicago (IL); London: University of Chicago Press.
- MOCEAN, Loredana (2007), 'Internet data validation', *Economy Informatics*, 1, 1, pp. 96-99.
- MONEDERO, Javier (2000), 'Parametric design: a review and some experiences', *Automation in Construction*, 9, 4, pp. 369-377.
- MONELLE, Raymond (1991), 'Music and the Peircean trichotomies', *International Review of the Aesthetics and Sociology of Music*, 22, 1, pp. 99-108.
- MORETTI, Franco (2005), *Graphs, maps, trees: abstract models for a literary history*, London; New York (NY): Verso.

- MORIARTY, Sandra (1994), 'Visual communication as a primary system', *Journal of Visual Literacy*, 14, 2, pp. 11-21.
- MUZERELLE, Denis (1985), *Vocabulaire codicologique: répertoire méthodique des termes français relatifs aux manuscrits Rubricae: histoire du livre et des textes*, Paris: Éditions CEMI.
- MUZERELLE, Denis (2002-2003), *Vocabulaire codicologique: répertoire méthodique des termes français relatifs aux manuscrits avec leurs équivalents en anglais, italien, espagnol. Edition hypertextuelle, Version 1.1*, <http://vocabulary.irht.cnrs.fr/> (Accessed 2011-12-29).
- MÜLLER, Pascal, WONKA, Peter, HAEGLER, Simon, ULMER, Andreas, VAN GOOL, Luc (2006), 'Procedural modeling of buildings', in *ACM SIGGRAPH 2006 Papers, SIGGRAPH 2006*, New York (NY): ACM, pp. 614-623.
- NEISSER, Ulric (1967/2014), *Cognitive Psychology*, New York (NY): Psychology Press.
- NISHIMOTO, Takehiko, UEDA, Takashi, MIYAWAKI, Kaori, UNE, Yuko, TAKAHASHI, Masaru (2010), 'A normative set of 98 pairs of nonsensical pictures (doodles)', *Behavior Research Methods*, 42, 3, pp. 685-691.
- NOEL, William (1995), 'The division of work in the Harley Psalter', in BROWNRIGG, Linda L. (Ed.), *Making the medieval book: techniques of production, Proceedings of the fourth conference of the seminar in the history of the book to 1500, Oxford, July 1992*, Los Altos Hills (CA); London: Anderson-Lovelace; Red Gull Press, pp. 1-15.
- NORDMANN, Alfred (2002), 'Another new Wittgenstein: the scientific and engineering background of the Tractatus', *Perspectives on Science*, 10, 3, pp. 356-384.
- OGLE, William (Ed.) (1882), *Aristotle: On the parts of animals*, translated by OGLE, William, London: K. Paul, Trench & Co.
- ONLINE ETYMOLOGY DICTIONARY (2014), *diagram*, *n.*, <http://www.etymonline.com/index.php?term=diagram> (Accessed 2014-08-09).
- OXFORD ENGLISH DICTIONARY (2014a), *diagram* (2), *n.*, <http://www.oed.com/view/Entry/51854> (Accessed 2014-08-09).
- OXFORD ENGLISH DICTIONARY (2014b), *listel*, *n.*, <http://www.oed.com/view/Entry/109006> (Accessed 2014-09-05).
- OXFORD ENGLISH DICTIONARY (2014c), *morpheme*, *n.*, <http://www.oed.com/view/Entry/122336> (Accessed 2014-08-03).
- OXFORD ENGLISH DICTIONARY (2014d), *percept*, *n.*, <http://www.oed.com/view/Entry/140554> (Accessed 2014-08-03).

- OXFORD ENGLISH DICTIONARY (2014e), *phoneme*, *n.*, <http://www.oed.com/view/Entry/142626> (Accessed 2014-08-03).
- OXFORD ENGLISH DICTIONARY (2014f), *proposition*, *n.*, <http://www.oed.com/view/Entry/152801> (Accessed 2014-08-03).
- OXFORD ENGLISH DICTIONARY (2014g), *sememe*, *n.*, <http://www.oed.com/view/Entry/175577> (Accessed 2014-08-03).
- OXFORD ENGLISH DICTIONARY (2015a), *verbal*, *adj.*, <http://www.oed.com/view/Entry/222360> (Accessed 2015-05-05).
- OXFORD ENGLISH DICTIONARY (2015b), *visual*, *adj.*, <http://www.oed.com/view/Entry/224004> (Accessed 2015-05-05).
- PAIVIO, Allan (1971), *Imagery and verbal processes*, New York (NY): Holt, Rinehart and Winston.
- PAIVIO, Allan (1975), 'Imagery and long-term memory', in KENNEDY, Alan and WILKES, Alan (Eds.), *Studies in long term memory*, London: John Wiley & sons, pp. 57-85.
- PAIVIO, Allan (1986), *Mental representations: a dual coding approach*, Oxford; New York (NY): Oxford University Press; Clarendon Press.
- PAIVIO, Allan (1991), *Images in mind: the evolution of a theory*, New York (NY): Harvester Wheatsheaf.
- PAIVIO, Allan (2007), *Mind and its evolution: a dual coding theoretical approach*, Mahwah (NJ): L. Erlbaum Associates.
- PAIVIO, Allan and CLARK, J.M. (1990), 'Static versus dynamic imagery', in CORNOLDI, Cesare and McDANIEL, Mark A. (Eds.), *Imagery and cognition*, New York (NY): Springer-Verlag.
- PAIVIO, Allan and CSAPO, Kalman (1973), 'Picture superiority in free recall: imagery or dual coding?', *Cognitive Psychology*, 5, 2, pp. 176-206.
- PALMER, Stephen E. (1975), 'The effects of contextual scenes on the identification of objects', *Memory & Cognition*, 3, 5, pp. 519-526.
- PALMER, Stephen E. (1999), *Vision science: photons to phenomenology*, Cambridge (MA): MIT Press.
- PALMER ELBRIDGE, Betsy (1993), 'Sewing variations outline', in *Standards, Seminar on Standards of Excellence in Hand Bookbinding*, Boston (MA): Guild of book workers.
- PALMER ELBRIDGE, Betsy and PRIOR, Anna (2008), 'A sewing presentation: stitches and sewing for bookbinding structures', in *Standards, Seminar on Standards of Excellence in Hand Bookbinding*, Toronto, Canada: Guild of book workers.

- PANG, A. (2001), 'Visualizing uncertainty in geo-spatial data', *Paper prepared for a committee of the Computer Science and Telecommunications Board, National Research Council. Computer Science Department, University of California, Santa Cruz*, pp. 1-14.
- PANG, Alex T., WITTENBRINK, Craig M., LODHA, Suresh K. (1997), 'Approaches to uncertainty visualization', *The Visual Computer*, 13, 8, pp. 370-390.
- PAZZI, Luca (1999), 'Implicit versus explicit characterization of complex entities and events', *Data & Knowledge Engineering*, 31, 2, pp. 115-134.
- PEIRCE, Charles S. (1931-1935/1958), *Collected papers of Charles Sanders Peirce: science and philosophy and reviews, correspondence and bibliography*, vols. 1-6, 1931-1935, edited by Charles Hartshorne and Paul Weiss, vols. 7-8, 1958, edited by Arthur W. Burks, Cambridge (MA): Harvard University Press.
- PEIRCE, Charles S. (1992-1998), *The essential Peirce: selected philosophical writings*, edited by HOUSER, Nathan, KLOESEL, Christian J. W., PEIRCE EDITION PROJECT, Bloomington (IN): Indiana University Press.
- PETERSEN, Theodore C. (1948), *Coptic bindings in the Pierpont Morgan Library*, unpublished manuscript in the Pierpont Morgan Library, New York (NY).
- PETERSEN, Theodore C. (1954), 'Early Islamic bookbindings and their Coptic relations', *Ars Orientalis*, 1, pp. 41-64.
- PETHERBRIDGE, Guy (1987), 'Introduction', in PETHERBRIDGE, Guy (Ed.), *Conservation of library and archive materials and the graphic arts*, London: Butterworths.
- PETRUCCI, Armando (2001), *La descrizione del manoscritto: storia, problemi, modelli*, Roma: Carocci Editore.
- PETTITT, Paul and PIKE, Alistair (2007), 'Dating European palaeolithic cave art: progress, prospects, problems', *Journal of Archaeological Method and Theory*, 14, 1, pp. 27-47.
- PICKWOOD, Nicholas (1995), 'The interpretation of bookbinding structure: an examination of sixteenth-century bindings in the Ramey Collection in the Pierpont Morgan Library', *The Library*, 17, 3, pp. 209-249.
- PICKWOOD, Nicholas (2000), 'Tacketed bindings: a hundred years of European bookbinding', in FOOT, Mirjam and PEARSON, David (Eds.), *"For the Love of the Binding": studies in bookbinding history presented to Mirjam Foot*, London; New Castle (DE): British Library; Oak Knoll Press, pp. 119-167.
- PICKWOOD, Nicholas (2004), 'The condition survey of the manuscripts in the monastery of Saint Catherine on Mount Sinai', *The Paper Conservator*, 28, 1, pp. 33-61.

- PICKWOOD, Nicholas (2008), 'Reading Bindings: Bindings as evidence of the culture and business of books', in *Panizzi Lectures*, London: British Library.
- PICKWOOD, Nicholas (2011a), 'Library or Museum? The Future of Rare Book Collections and its Consequences for Conservation and Access', in *New approaches to book and paper conservation-restoration*, Horn/Wien: Berger.
- PICKWOOD, Nicholas (2011b), 'The Place of Bindings in the Study of the Book', *Sinaiticus - Bulletin of the Saint Catherine Foundation*, pp. 2-3.
- PICKWOOD, Nicholas (2012), 'An Unused Resource: Bringing the Study of Bookbindings out of the Ghetto', in MOUREN, Raphaële (Ed.), *Ambassadors of the book: competences and training for heritage librarians*, Berlin: De Gruyter Saur, pp. 83-94.
- PICKWOOD, Nicholas (2014b), 'The evidence of the forged SNML Sammelband book structure', in BREDEKAMP, HORST, BRÜCKLE, IRENE, NEEDHAM, PAUL (Eds.), *A Galileo forgery: unmasking the New York Sidereus Nuncius*, Berlin: De Gruyter, pp. 61-70.
- PICKWOOD, Nicholas (2014a), 'Binders' Gatherings', *lbt The Library: The Transactions of the Bibliographical Society*, 15, 1, pp. 63-78.
- PICKWOOD, Nicholas and GULLICK, Michael (2004), *Assessment manual. A guide to the survey forms to be used in St Catherine's Monastery*, <http://www.ligatus.org.uk/sites/default/files/manual20050110.pdf> (Accessed 2012-04-20).
- PICKWOOD, Nicholas and MCKITTERICK, Rosamond (2013), 'A Carolingian manuscript fragment from the ninth century in Amsterdam University Library, used as the binding for 'Band 1 e 22'', *Quaerendo*, 43, 3, pp. 185-213.
- PIETROSKI, Paul (2014), 'Logical Form', in ZALTA, Edward N. (Ed.), *The Stanford Encyclopedia of Philosophy*, Fall 2014, Stanford (CA): Stanford University.
- PINKER, Steven (1990), 'A theory of graph comprehension', in FREEDLE, Roy (Ed.), *Artificial intelligence and the future of testing*, Hillsdale (NJ): Lawrence Erlbaum Associates, pp. 73-126.
- PITT, David (2012), 'Mental Representation', in ZALTA, Edward N. (Ed.), *The Stanford Encyclopedia of Philosophy*, Winter 2012 edition, Stanford (CA): Stanford University, <http://plato.stanford.edu/archives/win2012/entries/mental-representation> (Accessed 2013-05-13).
- PIZLO, Zygmunt (2008), *3D shape: its unique place in visual perception*, Cambridge (MA): MIT Press.
- POBLOME, Jeroen and THEELEN, Joeri (2014), 'The digital excavation: best practices and lesson learnt in the field', in , *Digital Humanities Summer School, University of Leuven*, Leuven: .
- POLIDORO, Piero (2008), *Che cos'è la semiotica visiva*, Roma: Carocci Editore.

- POLLARD, Graham (1956), 'Changes in the Style of Bookbinding, 1550–1830', *The Library*, s5-XI, 2, pp. 71-94.
- POLLARD, Graham (1962), 'The Construction of English Twelfth-Century Bindings', *The Library*, s5-XVII, 1, pp. 1-22.
- POLLARD, Graham and POTTER, Esther (1984), *Early Bookbinding Manuals: An Annotated List of Technical Accounts of Bookbinding to 1840 Occasional publication / Oxford Bibliographical Society*, Oxford: Oxford Bibliographical Society.
- POLYAK, Stephen (1958), *Vertebrate visual system*, Chicago (IL): University of Chicago Press.
- PORTER, DOT (2013), 'Visualizations of TEI Ms Descriptions', forum post, 2013, <https://listserv.brown.edu/archives/cgi-bin/wa?A2=tei-l;775d4091.1307> (Accessed 2014-07-27).
- PORTER, DOT, EMERY, Doug, CAMPAGNOLO, Alberto (2014), *The Manuscript Collation Project*, <http://dorpdev.library.upenn.edu/collation/> (Accessed 2014-07-27).
- PRICE, Roger (1959), *Doodles*, London: Transworld Publishers.
- PRICE, Roger (1976), *Doodles #1*, Los Angeles (CA): Price/Sterne/Sloan.
- PUGLIESE, Silvia (2001), 'Stiff-board vellum binding with slotted spine', *Papier Restaurierung. Mitteilungen der IADA*, 2, Jahrbuch / supplement, pp. 93-101.
- PYLYSHYN, Zenon W. (1976), *Imagery and artificial intelligence*, London (ON): University of Western Ontario.
- PYLYSHYN, Zenon W. (1977), 'What the mind's eye tells the mind's brain: a critique of mental imagery', in NICHOLAS, John M. (Ed.), *Images, perception, and knowledge, Philosophy of Science Workshop at Ontario, Canada, May 1974*, Ontario: Springer Netherlands, pp. 1-36.
- PYLYSHYN, Zenon W. (1979), 'The rate of "mental rotation" of images: a test of a holistic analogue hypothesis', *Memory & cognition*, 7, 1, pp. 19-28.
- PYLYSHYN, Zenon W. (1981), 'The imagery debate: analog media vs. tacit knowledge', *Psychological Review*, 88, December, pp. 16-45.
- PYLYSHYN, Zenon W. (2003), *Seeing and visualizing: it's not what you think*, Cambridge (MA): MIT Press.
- PYLYSHYN, Zenon W. (2011), *Things and places: how the mind connects with the world*, Cambridge (MA): MIT Press.
- RAINS, Mike, CLARKE, Amanda, FULFORD, Mike (2014), *IADB - Integrated Archaeological Database system*, <http://www.iadb.org.uk/> (Accessed 2014-07-08).

- RAMSAY, Stephen (2004), 'Databases', in SCHREIBMAN, Susan, SIEMENS, Ray, UNSWORTH, John (Eds.), *A companion to digital humanities*, Oxford: Blackwell Publishing Ltd, pp. 20-30.
- RAUSCH, Edwin (1966), 'Das Eigenschaftsproblem in der Gestalttheorie der Wahrnehmung', in METZGER, Wolfgang and ERKE, H. (Eds.), *Handbuch der Psychologie. Wahrnehmung und Bewußtsein*, Göttingen: Verlag für Psychologie; Hogrefe, pp. 866-953.
- RAVENBERG, Heather (2012), *A data model to describe book conservation treatment activity*, MPhil Thesis, University of the Arts London, London.
- REASON, James (1990), *Human Error*, Cambridge: Cambridge University Press.
- REGEMORTER, Berthe van (1992), *Binding structures in the middle ages: a selection of studies Studia Bibliothecae Wittockiana*, Brussels; London: Bibliotheca Wittockiana; Maggs Bros.
- ROBERTS, Matt and ETHERINGTON, DON (1982/1994), *Bookbinding and the conservation of books: a dictionary of descriptive terminology*, electronic edition, edited by HENRY, Walter, Stanford (CA): Preservation Department, Stanford University Libraries.
- ROBINSON, James M. (Ed.) (1972-1977), *The facsimile edition of the Nag Hammadi codices*, Leiden: Brill.
- ROBINSON, James M. (Ed.) (1984), *The facsimile edition of the Nag Hammadi codices. Introduction*, Leiden: Brill.
- ROSCH, Eleanor (1973), 'On the internal structure of perceptual and semantic categories', in MOORE, T.E. (Ed.), *Cognitive Development and the Acquisition of Language*, New York (NY): Academic Press, pp. 111-144.
- ROSCH, Eleanor (1975), 'Cognitive reference points', *Cognitive psychology*, 7, 4, pp. 532-547.
- ROSCH, Eleanor (1977), 'Human categorization', in WARREN, Neil (Ed.), *Studies in cross-cultural psychology*, London: Academic Press.
- ROSCH, Eleanor (1978), 'Principles of categorization', in ROSCH, Eleanor and LLOYD, Barbara (Eds.), *Cognition and categorization*, New York (NY): John Wiley & Sons Inc, pp. 27-48.
- ROSCH, Eleanor and MERVIS, Carolyn B. (1975), 'Family resemblances: studies in the internal structure of categories', *Cognitive Psychology*, 7, 4, pp. 573-605.
- ROSCH, Eleanor, MERVIS, Carolyn B., GRAY, Wayne, JOHNSON, David, BRAEM, Penny (1976), 'Basic objects in natural categories', *Cognitive Psychology*, 8, 3, pp. 382-439.
- ROSE, Gillian (2012), *Visual methodologies: an introduction to researching with visual materials*, London; Thousand Oaks (CA): SAGE.

- ROSEN, Joe (2008), *Symmetry rules: how science and nature are founded on symmetry*, Berlin; Heidelberg: Springer.
- ROTHWELL, J. Dan (2012), *In the company of others: an introduction to communication*, Oxford; New York (NY): Oxford University Press.
- ROUSE, William B. and ROUSE, Sandra H. (1983), 'Analysis and classification of human error', *IEEE Transactions on Systems, Man and Cybernetics*, SMC-13, 4, pp. 539-549.
- ROUSSOU, Maria and DRETTAKIS, George (2003), 'Photorealism and non-photorealism in virtual heritage representation', in *Proceedings of the 4th International Conference on Virtual Reality, Archaeology and Intelligent Cultural Heritage*, Aire-la-Ville, Switzerland: Eurographics Association, pp. 51-60.
- RUBIN, Edgar (1915), *Synsoplevede Figurer: studier i psykologisk analyse*, København, og Kristiania: Gyldendal, Nordisk forlag.
- RUSSELL, Bertrand (1914), *Our knowledge of the external world as a field for scientific method in philosophy*, London; New York (NY): Routledge.
- RYAN, N. (1996), 'Computer-Based Visualisation of the Past: Technical 'Realism' and Historical Credibility', in HIGGINS, T., MAIN, P., LANG, L. (Eds.), *Imaging the Past: Electronic Imaging and Computer Graphics in Museums and Archaeology*, London: British Museum Press, pp. 95-108.
- RYAN, Marie-Laure (2014), 'Story/World/Media. Tuning the instruments of a media-conscious narratology', in RYAN, Marie-Laure and THON, Jan-Noël (Eds.), *Storyworlds across media. Toward a media-conscious narratology*, Lincoln (NE); London: University of Nebraska Press, pp. 25-49.
- SAATY, T.L. and OZDEMIR, M.S. (2003), 'Why the magic number seven plus or minus two', *Mathematical and Computer Modelling*, 38, 3-4, pp. 233-244.
- SAINT-MARTIN, Fernande (1990), *Semiotics of visual language*, Bloomington (IN); Indianapolis (IN): Indiana University Press.
- SALDANA, Marie (2014), 'An integrated approach to the procedural modeling of ancient cities and buildings', in *Digital Humanities 2014, the 25th joint international conference of the Association for Literary and Linguistic Computing and Association for Computers and the Humanities and the 6th joint international conference of the Alliance of Digital Humanities Organizations, Conference Abstracts, EPFL-UNIL University of Lausanne, 7-12 July 2014, Digital Humanities 2014*, University of Lausanne: EPFL-UNIL University of Lausanne, pp. 342-343.
- SALTHER, Stanley N. (1985), *Evolving hierarchical systems. Their structure and representation*, New York: Columbia University Press.



- SANDYWELL, Dr Barry (2012), *Dictionary of visual discourse. A dialectical lexicon of terms*, Aldershot; Burlington (VT): Ashgate.
- SAYIM, Bilge and CAVANAGH, Patrick (2011), 'What line drawings reveal about the visual brain', *Frontiers in Human Neuroscience*, 5, 118, pp. 1-4.
- SCHIANO, Diane J. and TVERSKY, Barbara (1992), 'Structure and strategy in encoding simplified graphs', *Memory & Cognition*, 20, 1, pp. 12-20.
- SCHMIDT-KÜNSEMÜLLER, Friedrich-Adolf (1987), *Bibliographie Zur Geschichte Der Einbandkunst Von Den Anfängen Bis 1985*, Wiesbaden: L. Reichert.
- SEBEOK, Thomas A (1991), *A sign is just a sign*, Bloomington: Indiana University Press.
- SEBEOK, Thomas (1994), *Signs. An introduction to semiotics*, Toronto; Buffalo (TX): University of Toronto Press, Scholarly Publishing Division.
- SHAH, Priti and MIYAKE, Akira (Eds.) (2005), *The Cambridge handbook of visuospatial thinking*, Cambridge: Cambridge University Press.
- SHANNON, Claude E. (1948a), 'A mathematical theory of communication', *Bell System Technical Journal*, 27, 4, pp. 623-656.
- SHANNON, Claude E. (1948b), 'A mathematical theory of communication', *Bell System Technical Journal*, 27, 3, pp. 379-423.
- SHARPE, John L. (Ed.) (1996), *Roger Powell, the Compleat Binder: Liber Amicorum Bibliologia*, Turnhout: Brepols.
- SHARPE, John L. (2000), 'Observations on data collection: drawing and recording information', in MISITI, Maria Cristina and FONDAZIONE PER LA CONSERVAZIONE E IL RESTAURO DEI BENI LIBRARI SPOLETO (Eds.), *Contributi e testimonianze*, Spoleto: Accademia Spoletina, pp. 103-133.
- SHEN, Dandan and WALTHER, Dirk B. (2012), 'Categorization of line drawings of natural scenes using non-accidental properties matches human behavior', *Journal of Vision*, 12, 9, pp. 593-640.
- SHEPPARD, Jennifer M. (1995), 'Some twelfth-century monastic bindings and the question of localization', in BROWNRIGG, Linda L. (Ed.), *Making the medieval book: techniques of production, Proceedings of the fourth conference of the seminar in the history of the book to 1500, Oxford, July 1992*, Oxford: Anderson-Lovelace; Red Gull Press, pp. 181-198.
- SHIFFRIN, Richard M. and SCHNEIDER, Walter (1977), 'Controlled and automatic human information processing: II. Perceptual learning, automatic attending and a general theory', *Psychological Review*, 84, 2, pp. 127-190.
- SHIN, Sun-Joo, LEMON, Oliver, MUMMA, John (2013), 'Diagrams', in ZALTA, Edward N. (Ed.), *The Stanford Encyclopedia of Philosophy*, Fall 2013 Edition, Stanford (CA): Stanford University.

- SHORT, Thomas L. (2007), *Peirce's theory of signs*, Cambridge; New York (NY): Cambridge University Press.
- SIMONS, Peter (1987), *Parts: a study in ontology*, Oxford; New York (NY): Oxford University Press.
- SMITH, E.E., BOLZANO, G.J., WALKER, J. (1978), 'Nominal, perceptual, and semantic codes in picture categorization', in COTTON, John W. and KLATZKY, Roberta L. (Eds.), *Semantic Factors in Cognition*, Hillsdale (NJ): Erlbaum, pp. 137-167.
- SNYDER, Joel (1980), 'Picturing vision', *Critical Inquiry*, 6, 3, pp. 499-526.
- SPERBERG-McQUEEN, C.M. and BURNARD, L. (Eds.) (2005), *Text Encoding Initiative P5: guidelines for electronic text encoding and interchange*, P5 revised and re-edited edition, Oxford; Providence (RI); Charlottesville (VA); Nancy (KY): Text Encoding Initiative Consortium.
- SPITZMUELLER, Pamela (1982), 'A trial terminology for describing sewing through the fold', *The Paper Conservator*, 7, 1, pp. 44-46.
- SPITZMUELLER, Pamela and FROST, Gary (1982), 'A trial terminology for sewing through the fold', *American Institute for Conservation of Historic and Artistic Works, Book and Paper Group, 10th Annual Meeting Postprints*, 1, p. 3.
- SPRINGER, Sally P. and DEUTSCH, George (1997), *Left brain, right brain: perspectives from cognitive neuroscience*, New York (NY): Freeman.
- STENNING, Keith and LEMON, Oliver (1999), 'Aligning logical and psychological perspectives on diagrammatic reasoning', *Artificial Intelligence Review*, 15, pp. 29-62.
- STERNBERG, Robert J. and MIO, Jeffery Scott (2009), *Cognitive psychology*, fifth edition, Australia; Belmont (CA): Cengage Learning; Wadsworth.
- STILLA, Uwe and MICHAELSEN, Eckart (1997), 'Semantic modelling of man-made objects by production nets', in GRUEN, Armin, BALSAVIAS, Emmanuel P., HENRICSSON, Olof (Eds.), *Automatic extraction of man-made objects from aerial and space images (II)*, Birkhäuser Basel: Springer, pp. 43-52.
- STINY, G. (1980), 'Introduction to shape and shape grammars', *Environment and Planning B: Planning and Design*, 7, 3, p. 343 – 351.
- STINY, George (2006), *Shape: talking about seeing and doing*, Cambridge (MA): MIT Press.
- STINY, George and GIPS, James (1972), 'Shape grammars and the generative specification of painting and sculpture', in FREIMAN, C. V. (Ed.), *Information Processing 71, IFIP Congress 71*, Ljubljana, Yugoslavia: Amsterdam: North- Holland, pp. 1460-1465.

- STOUTLAND, Frederick (1998), 'Wittgenstein: on certainty and truth', *Philosophical Investigations*, 21, 3, pp. 203-221.
- STROTHOTTE, Thomas, MASUCH, Maic, ISENBERG, Tobias (1999), 'Visualizing knowledge about virtual reconstructions of ancient architecture', in *Proceedings of the International Conference on Computer Graphics*, Washington (DC): IEEE Computer Society, pp. 36-43.
- STROTHOTTE, Thomas, PREIM, Bernhard, RAAB, Andreas, SCHUMANN, Jutta, FORSEY, David R. (1994), 'How to render frames and influence people', *Computer Graphics Forum*, 13, 3, pp. 455-466.
- STROTHOTTE, Thomas, PUHLE, Matthias, MASUCH, Maic, FREUDENBERG, Bert, KREIKER, Sebastian, LUDOWICI, Babette (1999), 'Visualizing uncertainty in virtual reconstructions', in *Proceedings of Electronic Imaging & the visual Arts, Berlin, EVA Europe 1999*, Berlin: Vasari, GfAI, pp. 16.
- STROTHOTTE, Thomas and SCHLECHTWEG, Stefan (2002), *Non-photorealistic computer graphics. Modeling, rendering, and animation*, San Francisco (CA): Morgan Kaufmann Publishers Inc..
- SZCZEPANOWSKA, Hanna M. (2013), *Conservation of Cultural Heritage: Key Principles and Approaches*, London; New York (NY): Routledge.
- SZIRMAI, János A. (1988), 'The girdle book of the museum Meermanno-Westreenianum', *Quaerendo*, 18, 1, pp. 17-34.
- SZIRMAI, János A. (1996), 'The archaeology of bookbinding and book restoration', *Quaerendo*, 26, 2, pp. 144-164.
- SZIRMAI, János A. (1999), *The archaeology of medieval bookbinding*, Aldershot; Burlington (VT): Ashgate.
- TALMY, Leonard (2000), 'How language structures space', in *Toward a cognitive semantics. Concept structuring systems*, Cambridge (MA): MIT Press, pp. 177-254.
- TANSELLE, G. Thomas (2002), *Introduction to bibliography: seminar syllabus for English/Comparative Literature, Columbia University*, Charlottesville (VA): Book Arts Press; University of Virginia.
- TERRAS, Melissa M. (2008), *Digital images for the information professional*, Aldershot; Burlington (VT): Ashgate Publishing Limited.
- TEXT ENCODING INITIATIVE CONSORTIUM (2014a), *10 Manuscript description. TEI P5 Guidelines*, <http://www.tei-c.org/release/doc/tei-p5-doc/en/html/MS.html> (Accessed 2014-07-27).
- TEXT ENCODING INITIATIVE CONSORTIUM (2014b), *TEI*, <http://www.tei-c.org/index.xml> (Accessed 2014-07-27).
- THOMAS, Nigel J.T. (2013), 'Mental imagery', in ZALTA, Edward N. (Ed.), *The Stanford Encyclopedia of Philosophy*, Spring 2013 edition, Stanford (CA): Stanford University, <http://plato.stanford.edu/archives/spr2013/entries/mental-imagery> (Accessed 2013-05-13).

- THOMSON, J., HETZLER, E., MACEachREN, A., GAHEGAN, M., PAVEL, M. (2005), 'A typology for visualizing uncertainty', in *Proceedings of Visualization and Data Analysis, IS&T/SPIE Symposium on Electronic Imaging, 16-20 January 2005*, San Jose (CA): , pp. 146-157.
- THOULESS, Robert H. (1931a), 'Phenomenal regression to the real object I', *British Journal of Psychology*, 21, pp. 339-359.
- THOULESS, Robert H. (1931b), 'Phenomenal regression to the real object II', *British Journal of Psychology*, 22, pp. 1-30.
- TOTH, Mike, BHAYRO, Siam, EMERY, Doug (2010), *Syriac palimpsest digital release README document*, [http://digitalgalen.net/0\\_ReadMe.html](http://digitalgalen.net/0_ReadMe.html) (Accessed 2014-07-27).
- TOTH, Mike, BHAYRO, Siam, EMERY, Doug (2013), *The digital Galen Syriac palimpsest*, <http://digitalgalen.net/> (Accessed 2014-07-27).
- TUFTE, Edward R. (1990), *Envisioning information*, Cheshire (CT): Graphics Press.
- TUFTE, Edward R. (1997), *Visual explanations: images and quantities, evidence and narrative*, Cheshire (CT): Graphics Press.
- TUFTE, Edward R. (2001), *The visual display of quantitative information*, Second Edition, Cheshire (CT): Graphics Press.
- TUFTE, Edward R. (2006), *Beautiful evidence*, Cheshire (CT): Graphics Press.
- TVERSKY, Barbara (1989), 'Parts, paronomies, and taxonomies', *Developmental Psychology*, 25, 6, pp. 983-995.
- TVERSKY, Barbara (1991), 'Distortions in memory for visual displays', in ELLIS, S.R., KAISER, M.K., GRUNWALD, A. (Eds.), *Pictorial communication in virtual and real environments*, London: Taylor & Francis, pp. 61-75.
- TVERSKY, Barbara (1997), 'Memory for pictures, maps, environments and graphs', in PAYNE, D. and CONRAD, F. (Eds.), *Intersections in Basic and Applied Memory Research*, Mahwah (NJ): Erlbaum, pp. 257-277.
- TVERSKY, Barbara (2001), 'Spatial schemas in depictions', in GATTIS, Merideth (Ed.), *Spatial schemas and abstract thought*, Cambridge (MA): MIT Press, pp. 79-111.
- TVERSKY, Barbara (2002), 'What do sketches say about thinking?', in STAHOVIC, T., LANDAY, J., DAVIS, R. (Eds.), *Proceedings of AAAI spring symposium on sketch understanding*, Menlo Park (CA): AAAI Press, pp. 148-151.
- TVERSKY, Barbara (2005c), 'Some ways images express and promote thought', in GRIALOU, P., LONGO, G., OKADA, M. (Eds.), *Images and Reasoning*, Tokyo: Keio University, pp. 15-29.

- TVERSKY, Barbara (2005a), 'Functional significance of visuospatial representations', in SHAH, Priti and MIYAKE, Akira (Eds.), *The Cambridge handbook of visuospatial thinking*, Cambridge; New York (NY): Cambridge University Press, pp. 1-34.
- TVERSKY, Barbara (2005b), 'Prolegomenon to scientific visualizations', in GILBERT, John K. (Ed.), *Visualization in Science Education*, Dordrecht: Springer Netherlands, pp. 29-42.
- TVERSKY, Barbara (2006), 'Visuospatial reasoning', in HOLYOAK, Keith James (Ed.), *The Cambridge handbook of thinking and reasoning*, Cambridge; New York (NY): Cambridge University Press, pp. 209-240.
- TVERSKY, Barbara (2007), 'Gestalts of thought', in ALBERTAZZI, Liliana (Ed.), *Visual thought: the depictive space of perception*, Amsterdam: Benjamins, pp. 155-163.
- TVERSKY, Barbara, AGRAWALA, Maneesh, HEISER, Julie, LEE, Paul, HANRAHAN, Pat, PHAN, Doantam, STOLTE, Chris, DANIEL, Marie-Paule (2007), 'Cognitive design principles for automated generation of visualizations', in ALLEN, Gary L. (Ed.), *Applied spatial cognition from research to cognitive technology*, London; New York (NY): Routledge, pp. 53-74.
- TVERSKY, Barbara and HEMENWAY, Kathleen (1984), 'Objects, parts, and categories', *Journal of Experimental Psychology. General*, 113, 2, pp. 169-197.
- TVERSKY, Barbara, ZACKS, Jeff, LEE, Paul, HEISER, Julie (2000), 'Lines, blobs, crosses and arrows: diagrammatic communication with schematic figures', in ANDERSON, Michael, CHENG, Peter, HAARSLEV, Volker (Eds.), *Theory and application of diagrams*, Berlin; Heidelberg: Springer-Verlag, pp. 221-230.
- TYLER, Andrea and EVANS, Vyvyan (2003), *The semantics of English prepositions. Spatial scenes, embodied meaning, and cognition*, Cambridge; New York (NY): Cambridge University Press.
- ULLMAN, David G (2010), *The mechanical design process*, 4th edition, international edition, Boston (MA): McGraw-Hill.
- VAN VALKENBURG, David and KUBOVY, Michael (2003), 'In Defense Of The Theory Of Indispensable Attributes', *Cognition*, 87, pp. 225-233.
- VARELA, FRANCISCO J., THOMPSON, EVAN T., ROSCH, ELEANOR (1991), *The embodied mind: cognitive science and human experience*, Cambridge (MA): MIT Press.
- VARZI, Achille (2014), 'Mereology', in ZALTA, Edward N. (Ed.), *The Stanford Encyclopedia of Philosophy*, Fall 2014 Edition, Stanford (CA): Stanford University, <http://plato.stanford.edu/archives/fall2014/entries/mereology> (Accessed 2014-09-09).
- VELIOS, Athanasios (2008), 'Hierarchical recording of binding structures', in *The Book and Paper Group Annual, American Institute for Conservation of Historic & Artistic Works 36th Annual*

- Meeting*, Denver, CO: American Institute for Conservation of Historic & Artistic Works, pp. 97.
- VELIOS, Athanasios (2014), 'Beyond databases. Linked open data for bookbinding descriptions', in *Men and books, From microorganisms to mega-organisms*, St. Pölten, Austria: Archive of the Diocese of St. Pölten in cooperation with ICARUS (International Centre for Archival Research) and the ERC (European Research Centre for Book and Paper Conservation).
- VELIOS, Athanasios and PICKWOOD, Nicholas (2004), 'Collecting Digital Data on Paper', in *Second international conference of museology - Technology for cultural heritage, 28<sup>th</sup> June - 2<sup>nd</sup> July 2004*, Mitilini: Καλειδοσκόπιο, pp. 650-658.
- VELIOS, Athanasios and PICKWOOD, Nicholas (2005a), 'Current use and future development of the database of the St Catherine's Library Conservation Project', *Paper Conservator*, 29, pp. 39-53.
- VELIOS, Athanasios and PICKWOOD, Nicholas (2005b), 'The Database of the St Catherine's Library Conservation Project in Sinai, Egypt', in *IS&T Archiving 2005 Conference, April 26-29*, Washington (DC): Society for Imaging Science and Technology, pp. 73-78.
- VELIOS, Athanasios and PICKWOOD, Nicholas (2008), 'Collecting and managing conservation survey data', in FELLOWS-JENSEN, Gillian and SPRINGBORG, Peter (Eds.), *Care and conservation of manuscripts 10: proceedings of the tenth international seminar held at the University of Copenhagen, 19th-20th October 2006*, *Care and conservation of manuscripts 10*, Copenhagen: Museum Tusulanum Press; University of Copenhagen, pp. 172-188.
- VELIOS, Athanasios and PICKWOOD, Nicholas (2009), 'An optimised workflow for large-scale condition surveys of book collections', in DRISCOLL, Matthew James and MÓSESDÓTTIR, Ragnheidur (Eds.), *Care and conservation of manuscripts 11: proceedings of the eleventh international seminar held at the University of Copenhagen 24th-25th April 2009*, *Care and conservation of manuscripts 11*, Copenhagen: Museum Tusulanum Press, University of Copenhagen, pp. 269-290.
- VELIOS, Athanasios and PICKWOOD, Nicholas (2012), 'The digitization of bookbindings', in NELSON, Brent and TERRAS, Melissa M. (Eds.), *Digitizing medieval and early modern material culture*, Tempe (AZ): Iter: Gateway to the Middle Ages and Renaissance Toronto, Ontario; Arizona Center for Medieval and Renaissance Studies (ACMRS), pp. 201-228.
- W<sub>3</sub>C (2003), *XML development history*, <http://www.w3.org/XML/hist2002> (Accessed 2015-04-25).
- W<sub>3</sub>C (2010), *Secret origin of SVG*, [http://www.w3.org/Graphics/SVG/WG/wiki/Secret-Origin\\_of\\_SVG](http://www.w3.org/Graphics/SVG/WG/wiki/Secret-Origin_of_SVG) (Accessed 2015-04-25).
- W<sub>3</sub>C (2015), *Extensible Markup Language (XML)*, <http://www.w3.org/XML/> (Accessed 2015-04-25).

- WAINER, Howard (2009), *Picturing the uncertain world. How to understand, communicate, and control uncertainty through graphical display*, Princeton (NJ): Princeton University Press,.
- WAKEMAN, Geoffrey (1993), *Functional Developments in Bookbinding*, Kidlington, Oxford ; New Castle, Delaware: Plough Press.
- WALTERS ART MUSEUM (2014a), *Describing manuscripts with TEI - Collation*, <http://thedigitalwalters.org/Supplemental/ManuscriptDescription.html#collation> (Accessed 2014-07-27).
- WALTERS ART MUSEUM (2014b), *The Digital Walters*, <http://www.thedigitalwalters.org/> (Accessed 2014-07-27).
- WALTHER, Dirk B., CHAI, Barry, CADDIGAN, Eamon, BECK, Diane M., FEI-FEI, Li (2011), 'Simple line drawings suffice for functional MRI decoding of natural scene categories', *Proceedings of the National Academy of Sciences*, 108, 23, pp. 9661-9666.
- WARE, Colin (2008), *Visual thinking for design*, Amsterdam: Morgan Kaufmann.
- WARE, Colin (2013), *Information visualization: perception for design*, Amsterdam: Morgan Kaufmann.
- WARWICK, Claire, FISHER, Claire, TERRAS, Melissa, BAKER, Mark, CLARKE, Amanda, FULFORD, Mike, GROVE, Matt, O'RIORDAN, Emma, RAINS, Mike (2009), 'iTrench: A study of user reactions to the use of information technology in field archaeology', *Literary and Linguistic Computing*, 24, 2, pp. 211-223.
- WEALE, W.H. James (1898), *Bookbindings and rubbings of bindings in the National Art Library, South Kensington Museum*, London: Printed for H. M. Stationery Off., by Eyre and Spottiswoode.
- WEBOPEDIA ([s.d.]), *Markup language*, [http://www.webopedia.com/TERM/M/markup\\_language.html](http://www.webopedia.com/TERM/M/markup_language.html) (Accessed 2014-03-22).
- WEBSTER, Graham (1964), *Romano-British coarse pottery: a student's guide*, York: Council for British Archaeology, [http://archaeologydataservice.ac.uk/catalogue/adsdata/arch-281-1/dissertation/pdf/cba\\_rr\\_006.pdf](http://archaeologydataservice.ac.uk/catalogue/adsdata/arch-281-1/dissertation/pdf/cba_rr_006.pdf) (Accessed 2011-12-15).
- WEISSTEIN, E. W. ([s.d.]), *Permutation. From MathWorld - A Wolfram Web Resource*, <http://mathworld.wolfram.com/Permutation.html> (Accessed 2014-03-19).
- WEYL, Hermann (1952), *Symmetry*, Princeton (NJ): Princeton University Press.
- WILKINSON, Leland (2005), 'Uncertainty', in *The Grammar Of Graphics*, Berlin; Heidelberg: Springer, pp. 451-488.
- WILLARD, William Franklin (2009), *The art of mechanical drawing: a practical course for drafting and design*, New York (NY): Hearst Books.

- WINSTON, P. H. (1975), 'Learning structural descriptions from examples', in WINSTON, D. H. (Ed.), *The psychology of computer vision*, New York (NY): McGraw-Hill.
- WISEMAN, Sandor, MACLEOD, Colin M., LOOTSTEEN, P.J. (1985), 'Picture recognition improves with subsequent verbal information', *Journal of experimental psychology. Learning, memory, and cognition*, 11, 3, pp. 588-595.
- WITTGENSTEIN, Ludwig (1922/2012), *Tractatus Logico-Philosophicus*, Side-by-side edition, version 0.29 (November 17, 2012), containing the original German, alongside both the Ogden/Ramsey, and Pears/McGuinness English translations, Amherst (MA): University of Massachusetts, <http://people.umass.edu/phil335-klement-2/ttp/ttp.pdf> (Accessed 2013-05-13).
- WITTGENSTEIN, Ludwig (1967), *Philosophical investigations*, third edition, translated by ANSCOMBE, G. E. M., Basil: Blackwell Publishing Ltd.
- WITTGENSTEIN, Ludwig (1969), *On certainty*, edited by ANSCOMBE, G. E. M. and WRIGHT, G. H. von, Oxford: Blackwell.
- WOOD, Jo, ISENBERG, Petra, ISENBERG, Tobias, DYKES, Jason, BOUKHELIFA, Nadia, SLINGSBY, Aidan (2012), 'Sketchy rendering for information visualization', *IEEE Transactions on Visualization and Computer Graphics*, 18, 12, pp. 2749-2758.
- WOOD, Phyllis and McDONNELL, Patrick (1994), *Scientific illustration: a guide to biological, zoological, and medical rendering techniques, design, printing, and display*, second edition, New York (NY): John Wiley & Sons.
- WRAGG, Richard (2012), 'Anybody know cheap/free software that's good for producing a diagram of a MS volume's bifolia / quires / construction? #medievalistproblems', @richdwragg twitter post, 22 November, <https://twitter.com/richdwragg/status/271614026415497216> (Accessed 2013-06-28).
- WRIGHT, Holly Ellen (2011), *Seeing triple. Archaeology, field drawing and the Semantic Web*, PhD Thesis, University of York, York, <http://etheses.whiterose.ac.uk/2194/1/WrightThesis.pdf> (Accessed 2014-03-05).
- WURFEL, Cliff (1989), 'Knot-tack sewing', *Binders' Guild Newsletter*, XII, 7, p. 14.
- YONG, Liu, CONGFU, Xu, ZHIGENG, Pan, YUNHE, Pan (2006), 'Semantic modeling for ancient architecture of digital heritage', *Computers & Graphics*, 5, pp. 800-814.
- ZAPPELLA, Giuseppina (1996), *Manuale del libro antico*, Milano: Editrice Bibliografica.
- ZHU, Xiaojin, GOLDBERG, Andrew B., ELDAWY, Mohamed, DYER, Charles R., STROCK, Bradley (2007), 'A text-to-picture synthesis system for augmenting communication', in *The Integrated Intelligence Track of the Twenty-Second AAAI Conference on Artificial Intelligence, AAAI-07*, Menlo Park (CA): AAAI Press, pp. 1590-1595.



- ZIMMERMANN, M. (1989), 'The nervous system in the context of information theory', *Human physiology*, 2, pp. 166-175.
- ZUK, Torre D. (2008), *Visualizing uncertainty*, PhD Thesis, Department of Computer Science, University of Calgary, Calgary, Alberta, Canada, [http://innovis.cpsc.ucalgary.ca/innovis/uploads/Publications/Publications/Zuk\\_2008\\_Visualizing\\_Uncertainty.pdf](http://innovis.cpsc.ucalgary.ca/innovis/uploads/Publications/Publications/Zuk_2008_Visualizing_Uncertainty.pdf) (Accessed 2014-06-12).
- ZUK, Torre D., CARPENDALE, S., GLANZMAN, W. D. (2005), 'Visualizing temporal uncertainty in 3D virtual reconstructions', in *Proceedings of the 6th International Conference on Virtual Reality, Archaeology and Intelligent Cultural Heritage*, Aire-la-Ville, Switzerland, Switzerland: Eurographics Association, pp. 99-106.
- ZUK, Torre D. and CARPENDALE, Sheelagh (2006), 'Theoretical analysis of uncertainty visualizations', in ERBACHER, Robert F., ROBERTS, Jonathan C., GRÖHN, Matti T., BÖRNER, Katy (Eds.), *Proceedings of SPIE Conference Electronic Imaging, Visualization and Data Analysis 2006*, San Jose Marriott and San Jose Convention Center, San Jose, California, USA: SPIE.
- ZUK, Torre D. and CARPENDALE, Sheelagh (2007), 'Visualization of uncertainty and reasoning', in BUTZ, Andreas, FISHER, Brian, KRÜGER, Antonio, OLIVIER, Patrick, OWADA, Shigeru (Eds.), *Smart Graphics*, Berlin, Heidelberg: Springer-Verlag, pp. 164-177.

## Illustration credits

Figure 1. Campagnolo 2015, after Donald 2001.....	5
Figure 2. Campagnolo 2015.....	9
Figure 3. Zhu <i>et al.</i> 2007.....	21
Figure 4. De Luca <i>et al.</i> 2005.....	26
Figure 5. Campagnolo 2015.....	33
Figure 6. Amigos 2015, <a href="http://www.amigos.co.uk/Our-Philosophy.aspx">www.amigos.co.uk/Our-Philosophy.aspx</a> .....	35
Figure 7. Campagnolo 2015, after Eco 1997.....	37
Figure 8. Campagnolo 2015.....	39
Figure 9. Campagnolo 2015.....	46
Figure 10. Campagnolo 2015.....	47
Figure 11. Campagnolo 2015; Saint Catherine monastery, Sinai, Egypt 2007.....	57
Figure 12. Petersen 1948.....	72
Figure 13. Dorsey 1989; Wurfel 1989.....	73
Figure 14. Benvestito 2012.....	74
Figure 15. Spitzmueller 1982.....	75
Figure 16. Saint Catherine monastery, Sinai, Egypt 2007.....	78
Figure 17. Webster 1964; Brodribb 1970.....	83
Figure 18. Gaskell 1972; Federici & Houlis 1988; Sheppard 1995; Clarkson 1996; Regemorter 1992.....	84
Figure 19. Muzerelle 1985; Noel 1995; Szirmai 1999.....	85
Figure 20. Campagnolo 2015.....	88
Figure 21. Szirmai 1988; Clarkson 1993; Adler 2010.....	89
Figure 22. Petersen 1954; Clarkson 1993; Boudalis 2007.....	91
Figure 23. Clarkson 2005; Pickwoad 2000; Szirmai 1999.....	93
Figure 24. Greenfield 1998.....	94
Figure 25. Bray 1607-1658, Rijksmuseum Amsterdam.....	96
Figure 26. Szirmai 1999.....	98
Figure 27. Carvin 1988.....	98
Figure 28. Greenfield 1990.....	99
Figure 29. Greenfield 1990.....	99
Figure 30. Bibliothèque Nationale (France) 1989.....	100
Figure 31. Szirmai 1999.....	127
Figure 32. Clarkson 2005.....	131
Figure 33. Velios & Pickwoad 2004.....	144
Figure 34. Ligatus 2007.....	146
Figure 35. Campagnolo 2015.....	148
Figure 36. Campagnolo 2015.....	152
Figure 37. Campagnolo 2015.....	154
Figure 38. Campagnolo 2015.....	155
Figure 39. Campagnolo 2015.....	159
Figure 40. Willard 2009.....	160
Figure 41. Campagnolo 2015.....	160
Figure 42. Campagnolo 2015.....	162

Figure 43. Szirmai 1999.....	163
Figure 44. Szirmai 1999; Carvin 1988; Middleton 1996; Cockerell 1953.....	164
Figure 45. Campagnolo 2015.....	165
Figure 46. Jäckel 1975; Greenfield 1990; Szirmai 1999; Clarkson 2005; Conn & Verheyen 2003b.....	167
Figure 47. Campagnolo 2015.....	168
Figure 48. Campagnolo 2015.....	170
Figure 49. Campagnolo 2015.....	171
Figure 50. Campagnolo 2015.....	171
Figure 51. Campagnolo 2015.....	173
Figure 52. Campagnolo 2015.....	174
Figure 53. Campagnolo 2015; Saint Catherine monastery, Sinai, Egypt 2007....	175
Figure 54. Campagnolo 2015.....	176
Figure 55. Campagnolo 2015.....	179
Figure 56. Campagnolo 2015.....	179
Figure 57. Campagnolo 2015.....	180
Figure 58. Campagnolo 2015.....	182
Figure 59. Campagnolo 2015, after Pickwoad & Gullick 2004.....	182
Figure 60. Szirmai 1999; Carvin 1988.....	183
Figure 61. Middleton 1996.....	184
Figure 62. Campagnolo 2015.....	185
Figure 63. Campagnolo 2015.....	185
Figure 64. Campagnolo 2015.....	186
Figure 65. Campagnolo 2015.....	186
Figure 66. Campagnolo 2015.....	187
Figure 67. Campagnolo 2015.....	187
Figure 68. Campagnolo 2015.....	187
Figure 69. Campagnolo 2015.....	188
Figure 70. Campagnolo 2015.....	189
Figure 71. Campagnolo 2015.....	189
Figure 72. Campagnolo 2015.....	190
Figure 73. Campagnolo 2015.....	190
Figure 74. Saint Catherine monastery, Sinai, Egypt 2007.....	191
Figure 75. Campagnolo 2015.....	192
Figure 76. Saint Catherine monastery, Sinai, Egypt 2007.....	192
Figure 77. Campagnolo 2015.....	193
Figure 78. Saint Catherine monastery, Sinai, Egypt 2007.....	193
Figure 79. Campagnolo 2015.....	194
Figure 80. Campagnolo 2015.....	194
Figure 81. Saint Catherine monastery, Sinai, Egypt 2007.....	195
Figure 82. Campagnolo 2015.....	195
Figure 83. Saint Catherine monastery, Sinai, Egypt 2007.....	195
Figure 84. Campagnolo 2015.....	195
Figure 85. Saint Catherine monastery, Sinai, Egypt 2007.....	196
Figure 86. Campagnolo 2015.....	196

Figure 87. Saint Catherine monastery, Sinai, Egypt 2007.....	197
Figure 88. Campagnolo 2015.....	197
Figure 89. Campagnolo 2015.....	198
Figure 90. Campagnolo 2015.....	198
Figure 91. Saint Catherine monastery, Sinai, Egypt 2007.....	199
Figure 92. Campagnolo 2015.....	199
Figure 93. Campagnolo 2015.....	199
Figure 94. Campagnolo 2015.....	203
Figure 95. Campagnolo 2015.....	203
Figure 96. Campagnolo 2015.....	204
Figure 97. Campagnolo 2015.....	205
Figure 98. Campagnolo 2015.....	206
Figure 99. Campagnolo 2015.....	207
Figure 100. Szirmai 1999; Szirmai 1996.....	209
Figure 101. Campagnolo 2015.....	210
Figure 102. Campagnolo 2015.....	211
Figure 103. Szirmai 1999.....	213
Figure 104. Campagnolo 2015.....	214
Figure 105. Campagnolo 2015.....	215
Figure 106. Campagnolo 2015.....	217
Figure 107. Campagnolo 2015.....	218
Figure 108. Campagnolo 2015.....	219
Figure 109. Campagnolo 2015.....	219
Figure 110. Campagnolo 2015.....	220
Figure 111. Campagnolo 2015.....	221
Figure 112. Campagnolo 2015.....	224
Figure 113. Campagnolo 2015.....	225
Figure 114. Campagnolo 2015.....	226
Figure 115. Campagnolo 2015.....	227
Figure 116. Campagnolo 2015.....	229
Figure 117. Campagnolo 2015.....	229
Figure 118. Campagnolo 2015.....	230
Figure 119. Campagnolo 2015.....	231
Figure 120. Campagnolo 2015.....	232
Figure 121. Campagnolo 2015.....	233
Figure 122. Campagnolo 2015.....	234
Figure 123. Campagnolo 2015.....	235
Figure 124. Saint Catherine monastery, Sinai, Egypt 2007.....	237
Figure 125. Saint Catherine monastery, Sinai, Egypt 2007.....	238
Figure 126. Campagnolo 2015.....	238
Figure 127. Campagnolo 2015; Saint Catherine monastery, Sinai, Egypt 2007..	240
Figure 128. Campagnolo 2015; Saint Catherine monastery, Sinai, Egypt 2007..	240
Figure 129. Campagnolo 2015; Saint Catherine monastery, Sinai, Egypt 2007..	240
Figure 130. Campagnolo 2015; Saint Catherine monastery, Sinai, Egypt 2007..	240
Figure 131. Campagnolo 2015.....	243

Figure 132. Campagnolo 2015.....	249
Figure 133. Campagnolo 2015.....	270
Figure 134. Schoenberg Institute for Manuscript Studies, Manuscript Collation Project 2015.....	273
Figure 135. Campagnolo 2015.....	319