

Implementation of Microcontroller to Control Solar Water Pump at Different Time Slots

M. Pratyusha, Nagi Reddy, B. C. V. Vijay Kumar

Abstract: Many people are using non renewable energy sources in high amount of their needs. Some Minerals are exhausting with the high usage, so it is obvious to depend on the renewable sources like solar & wind etc. In this paper a solar energy based water pump system with different time slots are proposed. The solar energy is converted into electrical energy by photovoltaic cells and it charges the battery. During Day time battery stores the energy. In this project AT89S52 microcontroller are used. For this microcontroller the program is written for giving different time slots. One 16*2 LCD display is using to see the status of system. For adjusting contract display one variable resistor called 'preset' is used. One sensor is used to observe the water level and to send data back to the microcontroller. The manual ON/OFF control of the system can be avoided with this sensor. This is a new method to operate motor / machine for a small duration. Buzzer gives a beep sound. A transistor is used to drive the relay during on time period; relay is used to control the pump. A switching diode is used to control the reverse EMF. The proposed system has the advantage of automatic switch off for the given time. This will be the one of best solutions for smart solar irrigation for farmers. In addition, this solar system controls the flow of water across the field.

Keywords: solar panel, AT89S52 microcontroller, water pump, 16*2 LCD Display, Battery charger

I. INTRODUCTION

In every country irrigation plays main role in this paper we develop the automatic solar water pumping system at low cost for irrigation developing country. We arrange the one programmed sensor module detect the temperature and soil moisture level and send this data to microcontroller. Water level sensors also observe the water level and send the data to the microcontroller unit [1-3]. Based on the sensor alerts microcontroller unit decide whether motor is on or off. This paper also describes the detailed working function of the microcontroller in soil. If the server is connected to the microcontroller system then the motor on and off can be controlled by using mobile phone. Now a day's most of the people are using solar energy [4-7]. The purposed system has the additional features to know the temperature and water flow of the system.

In this paper a micro controller based mater pumping system using stand alone solar system is proposed. Solar energy is used in this method for feeding the irrigation loads.

Revised Manuscript Received on January 27, 2020.

* Correspondence Author

M. Pratyusha*, Asst. Prof, EEE Dept, GITAM school of technology, Bangalore, India. Email: pratyugitas09@gmail.com

B. Nagi Reddy, Asst. Prof, EEE Dept, Vignana Bharathi Institute of Technology, Hyderabad, India. Email: nagireddy208@gmail.com

C. V. Vijay Kumar, Asst. Prof, EEE Dept, Vignana Bharathi Institute of Technology, Hyderabad, India.

To make this system economical and effective, a battery system is adopted for this application. So the main aim of this paper is to cut down the cost and make the efficient water pumping system for a field irrigation system [8, 9].

In private houses water is a playing major role. For Pure water we are using purifiers. By using renewable energy we can reduce this electric water purification so automatically usage of electricity is also reduced [10]. This solar energy converted into electrical to run the AC Submersible pump. Photovoltaic (PV) technique is created by solar energy. For irrigation purpose we are using microcontroller based water pumping system.

Basically agriculturist who have cultivated in India they are so far away from water source [11]. These farmer needs to install water pumping system to irrigate their farm area. There is required electrical power by supplying from governments it's so expensive for maintaining. Now a day's solar water pump system is one of system is applied photovoltaic panel. In day it's observe the heat from Sun and it's convert to power and it's operate [12]. In this process reduce the cost Compare to diesel and electrical energy cost. Free from the pollution. In this process we store the energy in battery and run at night time. Therefore this paper aim is design the development of solar water pump with charge controller for battery.

Now a day's water heating purpose we use different machines. In this paper the overview water heater use the solar energy for domestic water heating purpose. Its expensive compare remaining Machines that's the reason we develop solar energy system include green energy source. Thermal collector presents in the equipment its collect the heat. For control purpose we the sensors and PLC's actuators finally we control heat and use for domestic purpose [13]. For solar applications we can use DC motors also. This DC motor is controller for solar water pump. By using three phase induction motor we will get good efficiency.

Photovoltaic cells usually generated different types of variable power. If dc voltage obtained from PV system it's increased by the help of buck boost converters this energy is used in different applications. In this paper we develop the DC- DC converter double the buck-boost operation [5, 8, 14]. This converter used in low power application like solar water purifier system. In this process we used the conversational converter instead of two controlled switch only one switch is arranged it's made up of MOSFET. For good quality and efficiency purpose two inductors and two capacitors are used as energy transferring elements in the circuit design like DBB converter is analyzed with closed loop control using PI controller. This DBB converter we give the power supply to the unit of and electrical water purifier and water get purified.

Global system is very high demand for electrical energy and water. For Electrical energy we have renewable energy sources like solar, wind, tidal etc. An Automated solar power agriculture pumping system will give good results for electricity and water.

II. METHODOLOGY

A. AT89S52 Microcontroller

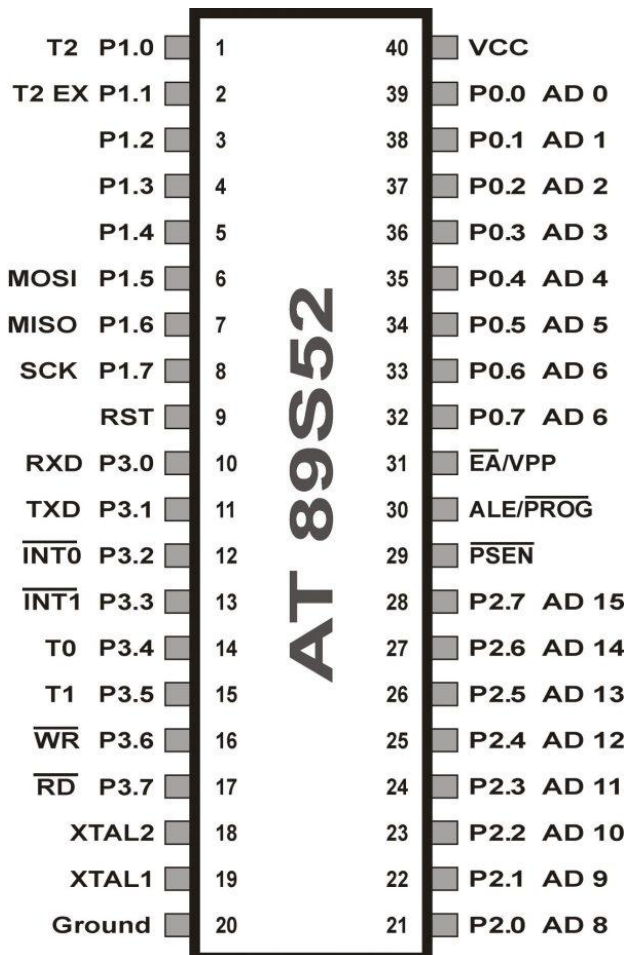

Fig 1. AT89S52 Microcontroller

Now days in embedded system we are using these microprocessors and microcontrollers. These are programmable device. Microcontroller contains a single metal oxide semiconductor (MOS) integrated circuit chip, and also contains one or more CPUs along with memory and input /output terminals. These are used in automatic controlled devices like remote controls, toys, automobile engine control systems.

The AT89S52 obtained from 8051 Atmel Microcontrollers. It is low power and high performance 8-bit CMOS microcontroller with 8k as flash memory and 256 bytes of RAM. This controller having 4 different ports, each one of them having 8 I/O ports, so total 32 I/O ports. Most of the ports used for two different functions. One is for input /output operation and other is one for counting external pulses, serial data transfer. Some microcontrollers use 4 bit word and operate at 4KHZ.

B. Bridge Rectifier

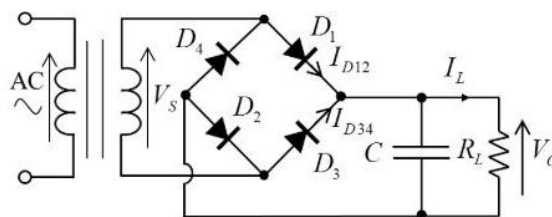

Fig 2. Bridge Rectifier

Rectifier converts AC signal in to DC signal, which flows in one direction. This process is known as Rectification .In this rectifier we can use either full wave, half wave, single phase AC, Three phase AC. These are used in different devices like DC power supplies, radio signals, home appliances for providing DC voltage. The main advantage of this bridge rectifier is polarity of the output is same as polarity at the input. Another advantage of this rectifier is if we use centre tapped transformer we can get output voltage is double. Here capacitor will store the energy. In this rectifier we are using step down transformer to change the amplitude of input voltage. For particular diode rectifier needs some considerations like peak inverse voltage (PIV), Forward current, voltage rating, Why because for producing DC current at the load side by conducting every half cycle of the input signal.

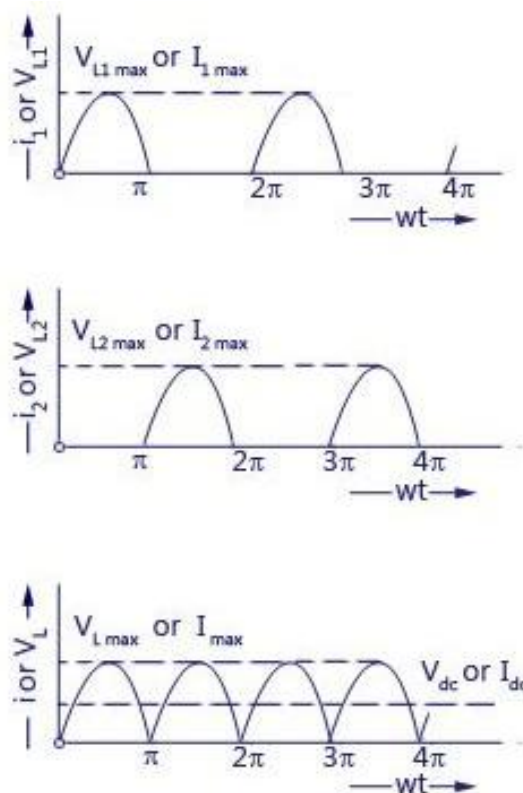

Fig 3. Output Waveforms

During first half cycle diode D₁ and D₃ are forward biased and D₂ and D₄ will be OFF state. Then current flowing through the diodes and it enters into load resistance R_L. During negative half cycle diode D₂, D₄ comes to forward biased and D₁, D₃ Will be in OFF state. The rectifier output waveforms are shown in Fig. 3.

C. Lead Acid Battery

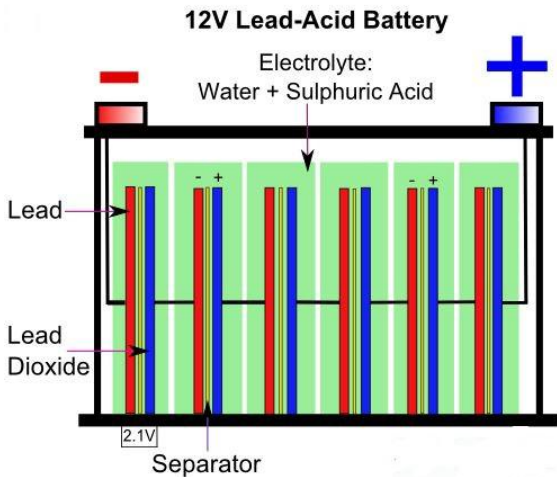

Fig 4. Lead Acid Battery

This battery made up of electrodes and electrolyte. For connecting electrolyte which operates the electrochemical reaction that provides electricity. In electrodes anode is negative terminal made up of solid lead and cathode is positive terminal made up of lead dioxide. In between cathode and anode one insulator / separator for avoiding short circuiting. The electrolyte is combination of water and sulphuric acid. It is one type of rechargeable battery and it stores energy in the form of chemical energy. When electrical energy is required this battery converts chemical energy into electrical energy. The material required for this battery is lead peroxide (PbO₂), Sponge lead (Pb), Dilute Sulfuric acid (H₂SO₄).

III. FILTER CIRCUIT

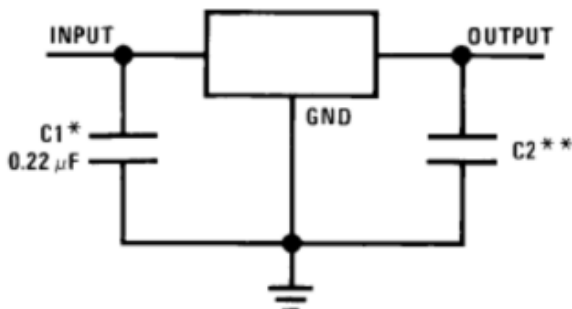

Fig 5. Filter circuit

This filter circuit is used for removing AC content in the output. This ac component completely removed and to get exact DC output. A filter circuit which removes the ac element in rectified circuit and allows dc element to reach the load. It is constructed by using two elements, i.e. inductor and capacitor. Fig. 5 shows the circuit of the filter configuration. Inductor allows DC and blocks AC, and capacitor allows ac and blocks dc. Here we are using capacitor filter so it allows ac and it blocks DC, it is known as shunt capacitor filter. The AC components are in grounded through the capacitor and remaining dc components collected at output side. Fig. 6 shows the complete block diagram representation of the proposed system.

IV. RESULTS

The battery of the proposed system is charged by solar energy and microcontroller is used to manage the smart water pump at different time slots which is automatic on / off control. In the manual irrigation based water system, the wastage of water is so high, so by using the proposed method the water wastage can be saved. In addition, the electricity is also saved because of the solar panels and battery regulatory system. The sequence of instructions has been given to the microcontroller which executes the program for different time slots to operate the water pump. The sensor is used to detect the water level and also sent this information back to the microcontroller. The program for the microcontroller is given below.

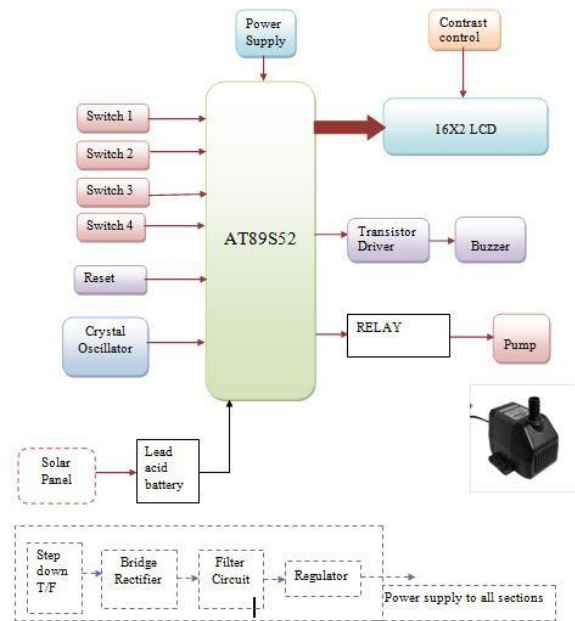

Fig 6. Block Diagram

SOURCE CODE:

```
#include<reg52.h>
#define ldata P2
sbit rs=P0^5;
sbit rw=P0^6;
sbit en=P0^7;
sbit relay=P0^0;
sbit sw0=P1^0;
sbit sw1=P1^1;
sbit sw2=P1^2;
sbit sw3=P1^3;
sbit b1=P1^4;
void lcdcmd(unsigned char);
void lcd_int(void );
void lcddata(unsigned char);
void msg(unsigned char *d);
void msdelay(unsigned char);
void delay1(unsigned char);
void main()
{
  unsigned char i=0;
  relay=1;
  b1=1;
  lcd_int();
  lcdcmd(0x01);
```

Implementation of Microcontroller to Control Solar Water Pump at Different Time Slots

```

lcdcmd(0x80);
msg("MOTOR CONTROL..");
  lcdcmd(0xC0);
msg("WITH4TIME SLOTS");
delay1(1);
while(1)
{
if(sw0==0)
{
lcdcmd(0x01);
b1=0;
while(sw0==0);
b1=1;
relay=0;
lcdcmd(0x80);
msg(" MOTOR ON ");
  lcdcmd(0xC0);
msg(" SLOT 1 ");
  for(j=0;j<=20;j++)
  {
    for(i=0;i<=200;i++)
    {
      delay1(800);
    }
  }
  relay=1;
}
else if(sw1==0)
{
lcdcmd(0x01);
b1=0;
while(sw1==0);
b1=1;
relay=0;
lcdcmd(0x80);
msg(" MOTOR ON ");
  lcdcmd(0xC0);
msg(" SLOT 2 ");
  for(j=0;j<=40;j++)
  {
    for(i=0;i<=200;i++)
    {
      delay1(800);
    }
  }
  relay=1;
}
else if(sw2==0)
{
lcdcmd(0x01);
b1=0;
while(sw2==0);
b1=1;
relay=0;
lcdcmd(0x80);
msg(" MOTOR ON ");
  lcdcmd(0xC0);
msg(" SLOT 3 ");
  for(j=0;j<=60;j++)
  {
    for(i=0;i<=200;i++)
    {
      delay1(800);
    }
  }
  relay=1;
}
else if(sw3==0)
{
lcdcmd(0x01);
b1=0;
while(sw3==0);
b1=1;
relay=0;
lcdcmd(0x80);
msg(" MOTOR ON ");
  lcdcmd(0xC0);
msg(" SLOT 4 ");
  for(j=0;j<=100;j++)
  {
    for(i=0;i<=200;i++)
    {
      delay1(800);
    }
  }
  relay=1;
}
else
{
  relay=1;
  lcdcmd(0x01);
  lcdcmd(0x80);
  msg(" MOTOR OFF ");
}
}

void lcd_int(void)
{
  lcdcmd(0x38);
  lcdcmd(0x80);
  lcdcmd(0x0e);
  lcdcmd(0x01);
  lcdcmd(0x06);
  lcdcmd(0x0c);
}

void msg(unsigned char *d )
{
  unsigned char j;
  for(j=0;d[j]!='\0';j++)
    lcddata(d[j]);
}

void lcdcmd(unsigned char value)
{
  ldata=value;
  rs=0;
  rw=0;
  en=1;
  msdelay(20);
  en=0;
  return;
}

void lcddata(unsigned char value)
{
  ldata=value;
  rs=1;
  rw=0;
  en=1;
  msdelay(20);
}

```



```

en=0;
return;
}
void msdelay(unsigned char value)
{
unsigned char i,j;
for(i=0;i<=value;i++);
for(j=0;j<=100;j++);
}
void delay1(unsigned char value)
{
unsigned char i,j;
for(i=0;i<=value;i++);
for(j=0;j<=230;j++);
}

```

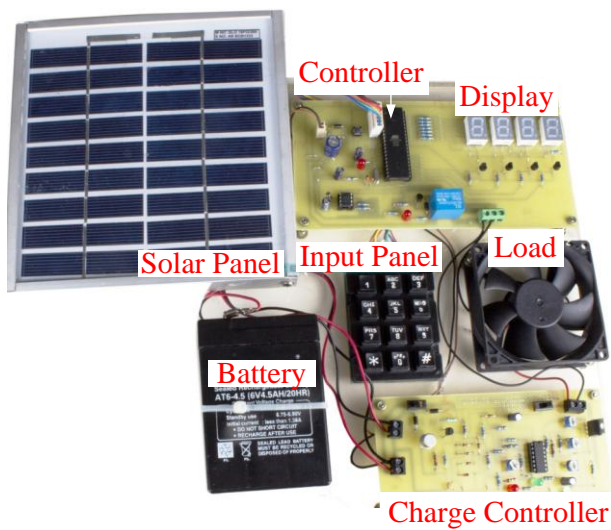

Fig 7. Hardware diagram of the proposed system



Fig 9. Output image of proposed system at pump OFF condition



Fig 8. Output image of proposed system at pump ON condition

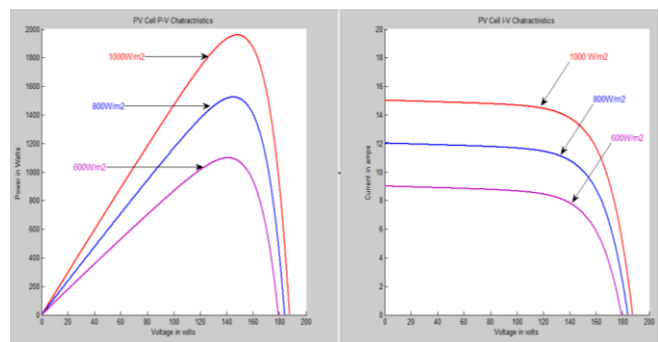

Fig. 10 Solar PV and IV curves for different irradiance levels

Figure 8 shows the turn ON condition of the proposed solar irrigation system. The different time slots have been given for the microcontroller to control the pump system automatically. According to the instructions at time 06:01 the system has to turn ON and at time 06:02 it has to be turn OFF. From fig. 8 it is clearly observe that at 06:01 time the water pump is turned ON (see the motor is rotating). On the other hand, the Fig. 9 represents the pump turn OFF condition. As already said, at time 06:02 automatically the water pump got turned OFF can be seen in Fig. 9. Fig. 10 shows the solar PV and IV curves at various irradiance conditions.

V. CONCLUSION

This paper gives a result to supply water for irrigation, where electricity is a problem. Advantages of this proposed system is that, no need of maintenance, no fuel requirement, gives long life, and easy installation. This project describes about automatic ON/OFF of the pump at different time slots. The proposed system is very useful for farmers in difficult situations for energy crisis problem. A sensor is used which indicates when the soil needs water. Automatic irrigation system is used to reduce the usage of water and reduces human work. Solar panels gives energy needed to the water pump. By using solar panels, the energy crisis problem can be avoided. It requires less maintenance and just small attention for self starting. Installation cost is more but it resolves more irrigation problems and gives long life.

REFERENCES

1. Shatadru Bipasha Biswas , M. Tariq Iqbal “solar water pumping control using a low cost ESP32 Microcontroller” in 2018 , IEEE Canadian conference on Electrical & Computer Engineering.
2. Washima Tasnin, Pradyumna Kumar Choudhury “ Deisgn and Development of an Automatic solar water heater controller” in 2015, IEEE
3. Xiaoming CUI, ZhiweiKOU, Yanjun QIAO “water level control system for solar water Heating Engineering based on PLC” in 2019, IEEE 3rd Information Technology , Networking , Electronic and Automation Control Conference
4. Prisma Megantoro, Fransisco Danang Wijaya “Deisgn of solar water pumping system in Urban Residential Building” in 2017, international Conference on control , Electronic, Renewable Energy And Communications .
5. Nagi Reddy. B, A. Pandian, O. Chandra Sekhar, M. Rammoorthy, “Design of Non-isolated integrated type AC-DC converter with extended voltage gain and high power factor for Class-C&D applications”. International Journal of Recent Technology and Engineering (IJRTE), Vol. 7, No. 5, Jan 2019, pp 230-236.
6. Prakhar Kumar Singh, Omveer Singh, SMIEEE, Shivam Pandey “Micro controller based water pumping system using solar energy” in 2018 5th IEEE Uttar Pradesh section international conference on Electrical ,Electronics and computer engineering.
7. B. Sreewirote , M. Leelajindakrairek “ Deisgn and Development Of solar Water Pump” in IEEE
8. Nagi Reddy. B, O. Chandra Sekhar, M. Ramamoorthy, “Analysis and implementation of single-stage buck-boost buck converter for battery charging applications”; Journal of Advanced Research in Dynamical and Control Systems (JARDCS), Vol. 10, No. 4, April 2018, pp 462-475.
9. Norlida Buniyamin, K.N.Y. Salah, A.Mohamed , Zaimuddin Mohammad “Low cost Solar Water Heater” in 2011, International conference On Electronic Device, Systems and Applications .
10. Nasifa Binte Yousuf, Khosru M .Salim , Rafid Haider, Md. Rajin Alam, Fatima Binte Zia “Development of a Three phase Induction Motor Controller for solar powered water Pump” in IEEE.
11. L. Sri Sivani, Nagi Reddy B, K. Subba Rao, A. Pandian, “A New Single Switch AC/DC Converter with Extended Voltage Conversion Ratio for SMPS Applications”. International Journal of Innovative Technology and Exploring Engineering (IJITEE), Vol. 8, No. 3, Jan 2019, pp 68-72.
12. G.Ezhilarasan, P.Balamurugan, Anilkumar K , Apoorva .y Suvarchaka K “Development of Two stage Buck –Boost Converter for solar PV based Rural Domestic water Purifier” in 2017,International conference on power , control, signals and Instrumentation Engineering.
13. Prasham Shah , vineeta s.chauhan “ Automatic solar submersible pump control for irrigation” in 2018, International journal of Advanced Scientific research and management”.
14. Nagi Reddy. B, A. Pandian, O. Chandra Sekhar, M. Ramamoorthy, “Performance and Dynamic Analysis of Single Switch AC-DC Buck-Boost Buck Converter”. International Journal of Innovative Technology and Exploring Engineering (IJITEE), Vol. 8, No. 4, Feb 2019, pp 68-72.

AUTHORS PROFILE



Ms. M .Pratyusha received her B. Tech degree in Electrical and Electronics engineering from GOKUL Institute of Technology ,bobbili under Jawaharlal Nehru Technological university Kakinada in 2013, M.Tech degree in Power Electronics from PYDAH college of Engineering under Jawaharlal Nehru Technological university , Kakinada in 2016. She is currently working as Assistant professor in electrical and electronics engineering department in GITAM school of Technology, Bangalore campus. Her area of interest are power electronics and drives.



Mr. B . Nagi Reddy received her B. Tech degree in Electrical and Electronics engineering from Mother Teresa Institute of Science & Technology, Sathupalli under Jawaharlal Nehru Technological university Hyderabad 2010, M.Tech degree in Power Electronics from Adam’s Engineering College under Jawaharlal Nehru Technological university , Hyderabad in Jan’ 13. He has done his PhD FullTime from K L University and submitted PhD thesis in June 2019. He is currently working as Assistant professor in electrical and electronics engineering department in Vignana Bharathi Institute of Technology, Hyderabad. His area of interests are design & control of DC-DC, AC-DC & DC-AC converters, Renewable energy sources, power electronic drives etc.



Mr. C.V. Vijay Kumar received his B.Tech degree in Electrical and Electronics Engineering from Shaaz College of Engineering and Technology , Moinsabad, Hyderabad from JNTUH in 2006, M.Tech degree in Power Electronics and Electrical Drives from CVSR College of Engineering , Hyderabad from JNTUH in 2012. He is currently working as Assistant professor in electrical and electronics engineering department in Vignana Bharathi Institute of Technology, Hyderabad. His area of interests are power electronics & drives.