

IOT Based Power Theft Detection

Prof. Sagar Shinde^{1,*}, Sachin Maskar², Anjali Pise², Sagar Salunkh²

¹Assistant Professor, Department of Electronics and Telecommunication, D Y Patil College Of Engineering, Ambi, Pune, Maharashtra, India

²Bachelor of Engineering, Department of Electronics and Telecommunication, D Y Patil College Of Engineering, Ambi, Pune, Maharashtra, India

*Email: sagar.shinde@dyptc.edu.com

DOI: <http://doi.org/10.5281/zenodo.2619924>

Abstract

The main objectives of this system are described clearly as follows: theft of electricity increases the costs paid by farmer and can have serious safety consequences. Many farmers are taking benefits of electricity. . But not all farmers are having legal electricity connection. Only those who have taken legal connection are paying the electricity charges. The farmers who are having legal electricity connection are paying charges of illegal connections and they don't have any idea about this theft of electricity. This system is basically developed for the welfare of farmers. We can use this system for the society, but installation charge more as compare to the electricity theft. Meter readings and rate every month send to the electricity providers through the IOT. Adding with these setup an efficient Internet of Things (IOT) is defined, which portrays the global connection environment to the users and allow them to view the status of meter reading and theft associations globally from anywhere at any time. Theft of electricity has a material impact on customers in terms of cost and safety. We consider that the existing regulatory framework does not adequately encourage suppliers to be proactive in detecting theft. In this document we are requesting views on proposed new supply license obligations to strengthen the arrangements for tackling theft and on the proposed role of Distribution Network Operators (DNOs) in tackling theft when it is not responsibility of suppliers. We are also consulting on additional policy measures and proposals to support suppliers in investigating, detecting and preventing theft. For all the entire system is useful for prevention of thefts and globally connected medium to portrait the meter reading through the IOT to its customers effectively.

Keywords: IOT, Wi-Fi, Power Distribution System, Distribution Network Operator, Microcontroller, LCD, ADC.

INTRODUCTION

Theft of electricity increases the costs paid by farmers and can have serious safety consequences. In particular, when it detects electricity theft by one of its customers, the supplier may incur liabilities relating to generation, network and balancing costs associated with the entry to the settlement system of estimates of the volume of electricity stolen by that people. Detecting electricity theft has been traditionally addressed by physical checks by the electricity provider company. The stolen electricity find out by the smart IoT system. This technique measures all

electricity used by the farmer and stolen by the illegal license customer. Other hand it will measure the running electricity losses, this losses can be consider for the more accuracy of power theft. . Common methods of theft range from compromising the physical security of meters to directly connecting loads to electricity distribution lines. Default of payments has been a major problem, due to suboptimal levels of monitoring and enforcement. The lack of technology and insufficient distributor incentives were the major contributors to this problem. Voltage divider circuit is used to measure the high incoming current

from the Power meter and shown in LCD Display. If you add load to the Power Meter it consume some power this value is shown in LCD. Voltage divider circuit is used to find the voltage level from main supply and shown in LCD. This voltage value is sent to IOT. This alert message is received by Distribution Network Operator instantly through web. The web message contains Recent Current, Voltage and Usage values. Units are displaying on the LCD module Display. In the Internet of Things (IoT) model, many of the living and non – living things that encompass us will be on the internet in one form or another. Driven by the popularity of gadgets empowered by wire - less technological innovation such as Radio Frequency Identification, Wireless - Fidelity, embedded sensor, IoT has moved out from its beginning stage and it is actually on the edge of changing the present fixed inter - net into a well featured upcoming Internet. Today the world is facing such an environment that offers challenges. Energy crisis is the main problem faced by our farmer. A relevant system to control and monitor the power usage is one of the solutions for this problem. One approach through which today's energy crisis can be addressed is through the reduction of power usage in Agricultures. The electricity usages by the farmers are increasing rapidly and also burden on electricity offering divisions is sharply increasing. The farmers must be facilitated by giving them an ideal solution: - i.e. the concept of IoT (Internet of Things) meters and on the other hand service provider end can also be informed about electricity thefts using theft detection unit. By keeping above factors, the concept of IoT meters thrived consisting of three different units: Microcontroller unit, voltage divider circuit and communication unit. The paper describes ARM 7 Microprocessor based design and implementation of energy meter using IoT and theft control concept. The Distribution Network operator can

monitor the energy consumption in units from a web page by providing device such as Smartphone. Theft detection unit connected before energy meter will notify company side when meter tampering occurs in energy meter and it will send theft detect information through efficient applications and theft detected will be displayed on the terminal window on the service provider end. Today's Demand actually requires accessing the device characteristics remotely in a reliable way. One of the possible ways to accomplish the task is to connect a device (energy meter) to internet by providing efficiency to it.

LITERATURE REVIEW

The electricity provider company equally divides electricity bill on the only customer they have authority of electricity usage, but illegal customer are not involved in this bill. The entire electricity bill paid by the license customers, they are very less amount of customers. The electricity provider company not able to took an individual meter reading of farmer. They are equate the all the usage charge on the few customers only they have authority. The illegal customers are safe and getting continuous benefits without any compensation, but indirectly that electricity usage charge filled by license farmer. So, we decide to overcome that illegal usage of electricity by using smart technology that is IOT. This system took continuous reading from the distribution system and upload on the web page through IOT. At the other side that is customer meter side also taking continuous meter reading and upload on the web page. The difference of electricity reading between the distribution system and customer meter are continuously check by the web automatically. The minor error or electricity losses can be calculated but we are not considering here. There have various discussions done on how to detect and prevent the power theft. Proposes a system design which incorporates an

android application and also indicates the exact zone on which unauthorized tapping is done in the real time when we using the GPS and data base.

PROPOSED SYSTEM

Energy is a necessary input in creation models along with capital, technology and labor and its sustainable supply at reasonable prices is estimated for a modern economy. It is therefore, a

permanent constraint to output development. Electricity shortfall effect economic development, causes joblessness, and increases the cost of manufacturing and doing increases farmer problems. Various studies specify the relationship among agricultural growth and electricity consumption either through a demand-side model. To full fill the demand of electricity consumers we need to prevent illegal usage of the electricity.

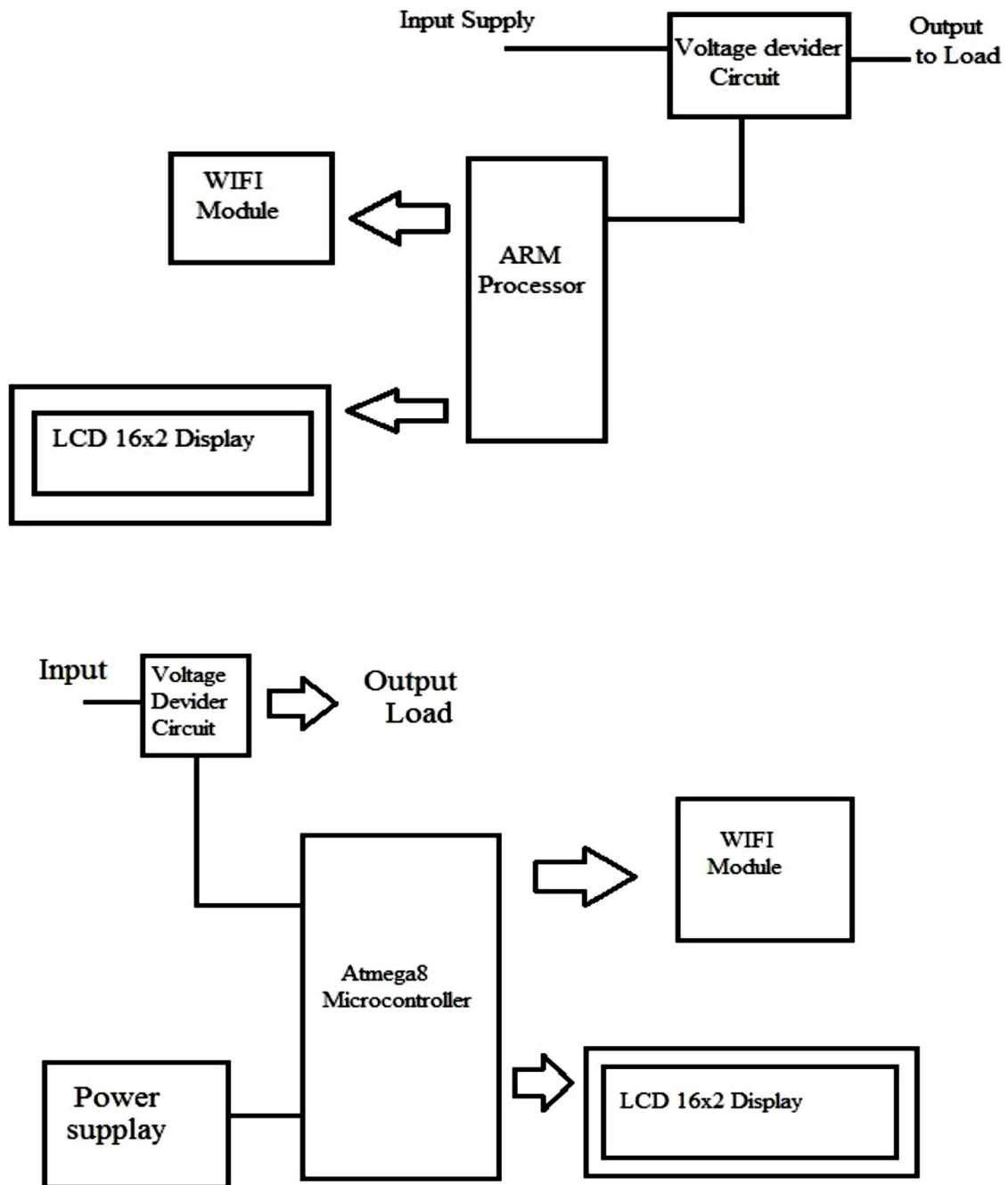

Figure 1: Block Diagram of Proposed System

Voltage Divider Circuit

The incoming power supply is very high, it is approximately 440V. This amount of power we cannot calculate directly and cannot access through the microcontroller. A voltage divider circuit is a simple circuit which turns a large voltage into a smaller one. We can create an output that is a fraction of the input. The potential divider which takes advantages of the way voltage drop across resistors is used in our range of electricity fields.

ARM7 Processor

ARM7 processor is a 32 bit RISC ARM processor cores licensed by ARM holding for microcontroller use. This device access a continuous reading from the voltage divider that voltage is minimum and measure it and transmit through the IOT. This ARM also provides input data to the LCD for displaying current power reading. It can handle multiple control action which is developer required. The incoming voltage is in the form of alternating current that is AC signal which cannot be directly measure. The one popular feature of ARM processor is inbuilt ADC which is convert this alternating current into binary that is called digital signal. This digital signal microcontroller can be access and measure. The measured digital value can be transfer to the web. Distribution network operator access the data whenever they want through web or Smartphone application.

LCD

The liquid crystal display is used to display the number. The LCD has 16 pin which differentiate that 5 pin for power control, 8 pin for data pin, 1 pin for read/write and 2 pins for its brightness. The LCD took data from the microcontroller and display on it. Whatever, the power variation made at the input which all the changes display on the LCD.

Primary Module (at Distribution Side)

The primary module placed at the side of electricity distribution system. It consist on the voltage divider CKT, ARM processor, Wi-Fi module and LCD display. The voltage divider circuit provides low electric signal that can be access by the ARM processor. The ARM processor measure that AC signal by the help of inbuilt ADC. The measured signal continuously uploading data to the web by the IOT and also display on the LCD display.

Secondary Module (at User Side)

The secondary module placed at the user side before meter. This module taking continuously reading coming from the distributed system i.e. coming from primary module. It provider measured electricity to the users. The measured amount of electricity displays on the LCD continuously. This is very beneficial for users because user can agree to how much electricity consume by the device.

IOT (Internet of Things)

The internet of things is the network of devices such as electronics and connectivity which these things to connect, interact and exchange data. It involves extending internet connectivity beyond standard devices such as desktops, laptops Smartphone and tablets. Here we use web or Smartphone for this application. The IOT took continuously reading from both primary and secondary modules and store to the web or Smartphone through the particular application. This application tolerates difference between these two modules. The difference between two modules should be equal. That means there is no power theft happened. It considers the minority power losses. When the difference between two modules become major that means power theft has been happened. How much amount of power theft by the peoples that can be observes by the distribution network operator through the IOT Technology

ADVANTAGES

- It is very economical as compared to electricity losses.
- Individual power theft can be calculated.
- Does not affect the power transfer capability of the line.
- It is very beneficial for farmer and also electricity Provider Company.

APPLICATIONS

- Used in power distribution system.
- We can use at the society if large amount of power theft is happen.

FUTURE SCOPE

- We can use GPS system to track exact location of power theft.
- We can save a continuous data reading when we using data base.
- We can use multiple secondary modules at every customer for better accuracy.

CONCLUSIONS

It is the anti-theft detection system. Even if theft is caught, the victim cannot get back his/her valuable belongings. That's why it is clear that 'prevention is better than cure'. By using this techniques crime of stealing power may be brought to an end

and thereby a new bloom may be expected in the economy of our motherland and also there will be less scarcity for power utilisation.

REFERENCES

1. S.patil, G.Pawaskar, K.patil., "Electrical Power Theft Detection and Wireless Meter Reading", International Journal of Innovative Research in Science, Engineering and Technology, Vol. 2, issue 4, pp. 1114 – 1119, April 2013
2. G.L. Prashanthi and K.V. Prasad., "Wireless Power Meter Monitoring with Power Theft Detection and Intimation System Using GSM and Zigbee Networks", IOSR Journals of Electronics and Communication Engineering(IOSR - JECE), vol. 9, issue 6, ver I,pp. 4 – 8.
3. P.R. Malhotra and R.Seethalakshmi, "Automatic Meter Reading and Theft Control System by Using GSM", International Journal of Engineering and Technology(IJET), Vol5, No 2, pp.806-810, Apr – May 2013.