

# Issues in Large Project Planning and Management

Lynne Siemens

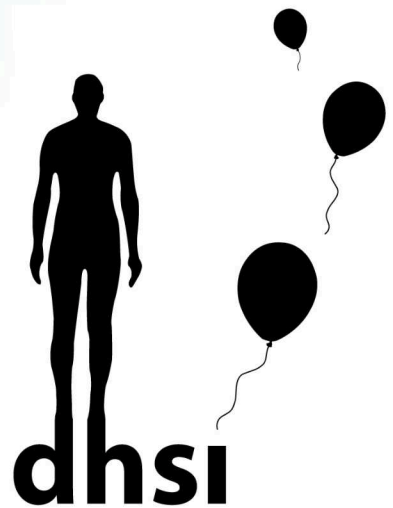

This package is intended for the personal, educational use of DHSI attendees.  
Portions appear here with consideration of fair use and fair dealing guidelines.  
© DHSI 2012



# Large Project Planning, Funding, and Management

## Session 1: Basics of Project Management



Session 1 Instructor –  
Lynne Siemens

Issues in Large Project Planning and  
Management, University of Victoria

---

---

---

---

---

---

---

---

# Eight Basic Principles of Project Management

- No major project is ever installed on time, within budget, with the same staff that started it. Yours will not be the first.
- Projects progress rapidly until they become 90 percent complete; they then remain 90 percent complete forever.
- One advantage of fuzzy project objectives is that they let you avoid the embarrassment of estimating the corresponding costs.
- When things are going well, something will go wrong.
  - When things just can't get any worse, they will.
  - When things appear to be going better, you have overlooked something.
- If project content is allowed to change freely, the rate of change will exceed the rate of progress.
- No system is ever completely debugged; attempts to debug a new system inevitably introduce new bugs that are even harder to find.
- A carelessly planned project will take three times longer to complete than you expected; a carefully planned project will only take twice as long.
- Project teams detest progress reports, because these reports vividly manifest their lack of progress.

<http://www.ucoick.org/~de/humour/projects.html>



Session 1 Instructor –  
Lynne Siemens

Issues in Large Project Planning and  
Management, University of Victoria

---

---

---

---

---

---

---

---

# Introduction

- Introduction – participants and their projects
  - Yourself
  - Your projects
  - Questions you would like answered



Session 1 Instructor –  
Lynne Siemens

Issues in Large Project Planning and  
Management, University of Victoria

---

---

---

---

---

---

---

---

## Agenda of Course

- **Session 1 – Basics of Project Management**
- **Session 2 – Project Teams and Groups/  
Project Start**
- **Session 3/4 – Project Planning and Model**
- **Session 5 – Project Change, Reporting  
and Managing Change**



Session 1 Instructor –  
Lynne Siemens

Issues in Large Project Planning and  
Management, University of Victoria

---

---

---

---

---

---

---

---

## Overview – Session 1

- Definition of project management
- General model of project management
- Building the project plan



Session 1 Instructor –  
Lynne Siemens

Issues in Large Project Planning and  
Management, University of Victoria

---

---

---

---

---

---

---

---

## Plan the Work –

## Now Work the Plan



Session 1 Instructor –  
Lynne Siemens

Issues in Large Project Planning and  
Management, University of Victoria

---

---

---

---

---

---

---

---

## Definition of Project Management

- Project Management is a set of principles, methods, tools and techniques for the effective management of objectives-oriented work in the context of a specific and unique organizational environment.



Session 1 Instructor –  
Lynne Siemens

Issues in Large Project Planning and  
Management, University of Victoria

---

---

---

---

---

---

---

---

## Successful Project Management Objectives

- Specified performance criteria
- Be within cost
- Be on schedule



Session 1 Instructor –  
Lynne Siemens

Issues in Large Project Planning and  
Management, University of Victoria

---

---

---

---

---

---

---

---

## Definition of a Project

- Key components
  - Not regular operations
  - Specific purpose or contract
  - Coordination of multiple tasks and resources
  - Specific cost, time and technical constraints
  - Not regularly repeated
  - Definite life cycle
  - Cross organizational boundaries and dissimilar skills
  - Relatively new or unknown undertakings
  - Uncertainty



Session 1 Instructor –  
Lynne Siemens

Issues in Large Project Planning and  
Management, University of Victoria

---

---

---

---

---

---

---

---

## Necessary Skills

- Negotiation
- Communication
- Team
- Analytical
- Evaluation



Session 1 Instructor –  
Lynne Siemens

Issues in Large Project Planning and  
Management, University of Victoria

---

---

---

---

---

---

---

---

## Examples

- New product or service
- Change in structure or staffing
- Building construction
- New business procedure



Session 1 Instructor –  
Lynne Siemens

Issues in Large Project Planning and  
Management, University of Victoria

---

---

---

---

---

---

---

---

## Model

- Problem identification
- Solution alternatives generation
- Solution selection
- Implementation planning
- Execution
- Progress analysis
- Project completion



Session 1 Instructor –  
Lynne Siemens

Issues in Large Project Planning and  
Management, University of Victoria

---

---

---

---

---

---

---

---

## Project Plan

- Tool for coordinating work
- Objectives
  - Determine and portray scope of work
  - Identify personnel and capital resources
  - Schedule work
  - Determine budget



Session 1 Instructor –  
Lynne Siemens

Issues in Large Project Planning and  
Management, University of Victoria

---

---

---

---

---

---

---

---

## Project Plan

- Essential questions to ask
  - What (technical objectives)
  - How (work breakdown structure)
  - Who (resource commitment and utilization plan)
  - When (schedule)
  - How much (budget)



Session 1 Instructor –  
Lynne Siemens

Issues in Large Project Planning and  
Management, University of Victoria

---

---

---

---

---

---

---

---

## Project Plan

- Benefits
  - Effective Communication
  - Final check
  - Baseline established
  - Reduces need for narrative reporting



Session 1 Instructor –  
Lynne Siemens

Issues in Large Project Planning and  
Management, University of Victoria

---

---

---

---

---

---

---

---

## Thought work

- Project Team – who/what skills
- Problem Definition



Session 1 Instructor –  
Lynne Siemens

Issues in Large Project Planning and  
Management, University of Victoria

---

---

---

---

---

---

---

---

# Large Project Planning, Funding and Management

## Session 2: Project Teams and Groups/ Project Start



Session 2 Instructor –  
Lynne Siemens

Issues in Large Project Planning and  
Management, University of Victoria

---

---

---

---

---

---

---

---

## Overview – Session 2

- Team Formation and Development
- Project Start/documentation



Session 2 Instructor –  
Lynne Siemens

Issues in Large Project Planning and  
Management, University of Victoria

---

---

---

---

---

---

---

---

## Project Team

- Researcher/Primary Investigator
- Project Manager
- Project Members



Session 2 Instructor –  
Lynne Siemens

Issues in Large Project Planning and  
Management, University of Victoria

---

---

---

---

---

---

---

---



## Role of Project Manager

- Day to day management of project
- Establishment of project structure
- Negotiation of written agreements
- Monitoring work
- Reporting progress
- Training and developing staff
- Developing a sense of team



Session 2 Instructor –  
Lynne Siemens

Issues in Large Project Planning and  
Management, University of Victoria

---

---

---

---

---

---

---

---

## Project Team Formation

- Who should be a part of it?
- Questions to consider
  - Would I want this individual working for me
  - Would I want this individual as one of my peers
  - Would I want to work for this individual
  - Consideration of availability, personal style, goals



Session 2 Instructor –  
Lynne Siemens

Issues in Large Project Planning and  
Management, University of Victoria

---

---

---

---

---

---

---

---

## Components of an Effective Team

- Performance
- Member satisfaction
- Team learning
- Outsider satisfaction



Session 2 Instructor –  
Lynne Siemens

Issues in Large Project Planning and  
Management, University of Victoria

---

---

---

---

---

---

---

---

## Skills/Responsibilities

- What skills are needed?
  - Skills inventory matrix
- Who will be responsible for what?
  - Responsibility matrix
- Assessing competence
  - Balance between skills and “good guy”



Session 2 Instructor –  
Lynne Siemens

Issues in Large Project Planning and  
Management, University of Victoria

---

---

---

---

---

---

---

---

## Building an Effective Team

- Team definition
  - small set of individuals who work interdependently and are jointly accountable for performance goals
- Stages
  - Forming
  - Storming
  - Norming
  - Performing



Session 2 Instructor –  
Lynne Siemens

Issues in Large Project Planning and  
Management, University of Victoria

---

---

---

---

---

---

---

---

## Team Effectiveness Model

- Evaluation
- Components
  - Organization and team environment
    - Reward systems, communication systems, physical space, organizational environment and leadership
  - Team design
    - Task characteristics, size, composition
  - Team process
    - Development, norms, roles, cohesiveness



Session 2 Instructor –  
Lynne Siemens

Issues in Large Project Planning and  
Management, University of Victoria

---

---

---

---

---

---

---

---

## Team Charter

- Description of how the team will work together
- Components
  - Team purpose
  - Ground rules for behaviour
  - Assign roles and responsibilities



Session 2 Instructor –  
Lynne Siemens

Issues in Large Project Planning and  
Management, University of Victoria

---

---

---

---

---

---

---

---

## Starting Point for Team Development

- **Team formation**
  - Introduction
  - Team building exercises
  - Operating agreements
- **Team planning**
  - Review task/expectations
  - Set objectives
  - Assign roles/responsibilities
  - Create workplan



Session 2 Instructor –  
Lynne Siemens

Issues in Large Project Planning and  
Management, University of Victoria

---

---

---

---

---

---

---

---

## Important considerations for diverse, far flung teams

- Communication
- Trust/accountability



Session 2 Instructor –  
Lynne Siemens

Issues in Large Project Planning and  
Management, University of Victoria

---

---

---

---

---

---

---

---

## Project Start

- Identification of need/problem
  - What is the issue to be addressed
  - Questions
    - Why do you want the project done
    - Why now
    - What are the risks
    - What are the costs
    - By what standard, will you measure results



Session 2 Instructor –  
Lynne Siemens

Issues in Large Project Planning and  
Management, University of Victoria

---

---

---

---

---

---

---

---

## Project documentation

- Key components
  - Problem/opportunity statement
  - Scope definition
  - Completion criteria
  - Assumptions
  - Impact statement
  - Risks
  - Resource requirements



Session 2 Instructor –  
Lynne Siemens

Issues in Large Project Planning and  
Management, University of Victoria

---

---

---

---

---

---

---

---

## Thought work

- What is the work that needs to be done for the project?



Session 2 Instructor –  
Lynne Siemens

Issues in Large Project Planning and  
Management, University of Victoria

---

---

---

---

---

---

---

---

# Large Project Planning, Funding and Management

## Session 3/4: Project Planning and Models



Session 3/4 Instructor –  
Lynne Siemens

Issues in Large Project Planning and  
Management, University of Victoria

---

---

---

---

---

---

---

---

## Overview – Session 3/4

- Planning the Work
  - Tools



Session 3/4 Instructor –  
Lynne Siemens

Issues in Large Project Planning and  
Management, University of Victoria

---

---

---

---

---

---

---

---

## Model the Work

- Work breakdown structure
- Network
- Critical path analysis
- Schedule



Session 3/4 Instructor –  
Lynne Siemens

Issues in Large Project Planning and  
Management, University of Victoria

---

---

---

---

---

---

---

---

## Work Breakdown Structure

- Determines all work efforts
- Checklist of every activity
- Use to assign responsibility



Session 3/4 Instructor –  
Lynne Siemens

Issues in Large Project Planning and  
Management, University of Victoria

---

---

---

---

---

---

---

---

## Work Breakdown Structure

- Complete and accurate?
  - Is it broken down to a level of detail that guarantees control
  - Do the work efforts begin with an active verb
  - Does each activity result in a deliverable
  - Is someone accountable for completing the project on time, within budget and at an acceptable level of quality



Session 3/4 Instructor –  
Lynne Siemens

Issues in Large Project Planning and  
Management, University of Victoria

---

---

---

---

---

---

---

---

## Network

- Sequence of tasks
  - All tasks from the WBS must appear
- Show visually the relationships of work activities to each other
- Only one start and one end
- Communication tool



Session 3/4 Instructor –  
Lynne Siemens

Issues in Large Project Planning and  
Management, University of Victoria

---

---

---

---

---

---

---

---

## Critical Path Analysis

- Longest sequence of tasks from start to finish
- Any delay on this path will delay entire project



Session 3/4 Instructor –  
Lynne Siemens

Issues in Large Project Planning and  
Management, University of Victoria

---

---

---

---

---

---

---

---

## Schedule

- Place data from WBS, network, critical path analysis on a time scale
- Know as Gantt chart
- Basic chart
  - Time
  - Tasks
- Include other information



Session 3/4 Instructor –  
Lynne Siemens

Issues in Large Project Planning and  
Management, University of Victoria

---

---

---

---

---

---

---

---

## Other Areas To Include

- Resource utilization chart
- Budget
- Risk assessment and contingency planning



Session 3/4 Instructor –  
Lynne Siemens

Issues in Large Project Planning and  
Management, University of Victoria

---

---

---

---

---

---

---

---

## Balance The Plan

- Balance limited resources
  - Within project
  - Against other projects
  - Against nonproject efforts
- Can the project be achieved given the other deadlines that are present



Session 3/4 Instructor –  
Lynne Siemens

Issues in Large Project Planning and  
Management, University of Victoria

---

---

---

---

---

---

---

---

## Approve and Publish

- Document includes:
  - Target completion date
  - Target cost
  - Target resource utilization
  - Target asset utilization
  - Objectives



Session 3/4 Instructor –  
Lynne Siemens

Issues in Large Project Planning and  
Management, University of Victoria

---

---

---

---

---

---

---

---

## Approve and Publish

- Serves as agreement among:
  - Project manager
  - Project client
  - Senior management
  - Functional managers
- Serves as basis for negotiating changes
- Signed and distributed



Session 3/4 Instructor –  
Lynne Siemens

Issues in Large Project Planning and  
Management, University of Victoria

---

---

---

---

---

---

---

---



# Large Project Planning, Funding and Management

## Session 5: Project Control, Reporting and Managing Change

Session 5 Instructor –  
Lynne Siemens

Issues in Large Project Planning and  
Management, University of Victoria



---

---

---

---

---

---

---

---

## Overview – Session 5

- Tracking Progress
- Managing Project Change
- Project Control/Reporting
- Project Review
- Software Tools/Internet Resources

Session 5 Instructor –  
Lynne Siemens

Issues in Large Project Planning and  
Management, University of Victoria



---

---

---

---

---

---

---

---

## Tracking Progress

- Planned versus actual
  - Gantt Chart
  - Budget
  - Etc.
- Do you make changes?

Session 5 Instructor –  
Lynne Siemens

Issues in Large Project Planning and  
Management, University of Victoria



---

---

---

---

---

---

---

---

## Managing Project Change/Project Control

- Key objectives
  - Determine what manager can/cannot control
  - Process for submitting change
  - Evaluating impact on project baseline
  - Documentation



Session 5 Instructor –  
Lynne Siemens

Issues in Large Project Planning and  
Management, University of Victoria

---

---

---

---

---

---

---

---

## Types of Changes

- Scope Changes
- Base Changes



Session 5 Instructor –  
Lynne Siemens

Issues in Large Project Planning and  
Management, University of Victoria

---

---

---

---

---

---

---

---

## Scope Changes

- Additions, modifications or deletions made to the end project or service
- Examples
  - Requirement changes
  - Design changes
  - Technological changes
  - Business changes
  - Personnel changes



Session 5 Instructor –  
Lynne Siemens

Issues in Large Project Planning and  
Management, University of Victoria

---

---

---

---

---

---

---

---

## Baseline Changes

- Baseline is the yardstick for measuring performance
- Examples
  - Project specifications
  - Applicable standards
  - Schedule target
  - Cost target
  - Resource and asset utilization



Session 5 Instructor –  
Lynne Siemens

Issues in Large Project Planning and  
Management, University of Victoria

---

---

---

---

---

---

---

---

## When is change needed?

- Tracked against actual performance
- Change may be required when not meeting plans
- Guidelines for change



Session 5 Instructor –  
Lynne Siemens

Issues in Large Project Planning and  
Management, University of Victoria

---

---

---

---

---

---

---

---

## Project Control

- Key questions to ask
  - Where are we
  - Where do we want to be
  - How do we get there
  - Are we getting there



Session 5 Instructor –  
Lynne Siemens

Issues in Large Project Planning and  
Management, University of Victoria

---

---

---

---

---

---

---

---

## Transition from Planning to Control

- Five step model
  - Update status
  - Analyze impact
  - Act on variances
  - Publish revisions
  - Inform management



Session 5 Instructor –  
Lynne Siemens

Issues in Large Project Planning and  
Management, University of Victoria

---

---

---

---

---

---

---

---

## 1. Update Status

- Sources of data
- Information for management in status reports
- Responsibilities for status reports
- Reporting techniques



Session 5 Instructor –  
Lynne Siemens

Issues in Large Project Planning and  
Management, University of Victoria

---

---

---

---

---

---

---

---

## 2. Analyze Impact

- Compare actual against planned
- Determine causes of differences
- Prepare analysis for future



Session 5 Instructor –  
Lynne Siemens

Issues in Large Project Planning and  
Management, University of Victoria

---

---

---

---

---

---

---

---

### 3. Act on Variances

- Choices
  - Do nothing
  - Make modifications
  - Negotiate trade offs



Session 5 Instructor –  
Lynne Siemens

Issues in Large Project Planning and  
Management, University of Victoria

---

---

---

---

---

---

---

---

### 4. Publish

- Format of status reports
  - Where are we today
  - Where will we be at the next report
  - What is our budget position
  - What items jeopardize project completion
  - Who deserves recognition



Session 5 Instructor –  
Lynne Siemens

Issues in Large Project Planning and  
Management, University of Victoria

---

---

---

---

---

---

---

---

### 5. Inform Management

- Information items
  - Major accomplishments since last review
  - Schedule status (actual vs plan)
  - Financial status (actual vs plan)
  - Major issues and action plans
  - Plans for next period
  - Special topics with sense of urgency
  - Review of action items and next meeting



Session 5 Instructor –  
Lynne Siemens

Issues in Large Project Planning and  
Management, University of Victoria

---

---

---

---

---

---

---

---

## 5. Inform Management

- Questions to answer
  - Foreseeable future problems
  - Adequate resources
  - Dissatisfaction among staff
  - Dealing with recurring problems
  - Lacking anything to do the job
  - Any changes to be addressed



Session 5 Instructor –  
Lynne Siemens

Issues in Large Project Planning and  
Management, University of Victoria

---

---

---

---

---

---

---

---

## Project Review Upon Completion

- Attainment of objectives
- Effectiveness of agreement
- Effectiveness of project plan, project organization and management systems
- Deficiencies and problems experienced
  - Any issues outstanding
- Lessons learned and suggested improvements



Session 5 Instructor –  
Lynne Siemens

Issues in Large Project Planning and  
Management, University of Victoria

---

---

---

---

---

---

---

---

## Tools

- what is needed given the project and team members' needs, geographical distribution, legal frameworks and other factors?
- “Low tech”
  - white board, flip charts, markers, calendar, post-it notes
- “Higher tech” (too many to talk about)
  - online calendars ([google](#)/outlook calendar)
  - online gantt charts ([google doc templates](#), [dotproject](#))
  - online project spaces ([basecamp](#), [asana](#))
  - folder/file sharing ([dropbox](#), [evernote](#))
  - many, many, many apps for iphone, ipad, etc



Session 5 Instructor –  
Lynne Siemens

Issues in Large Project Planning and  
Management, University of Victoria

---

---

---

---

---

---

---

---

## Back to the Beginning

- Have we answered/discussed your questions from the start of the workshop?
  - Any outstanding issues?



Session 5 Instructor –  
Lynne Siemens

Issues in Large Project Planning and  
Management, University of Victoria, 2012

---

---

---

---

---

---

---

---

# Project Management

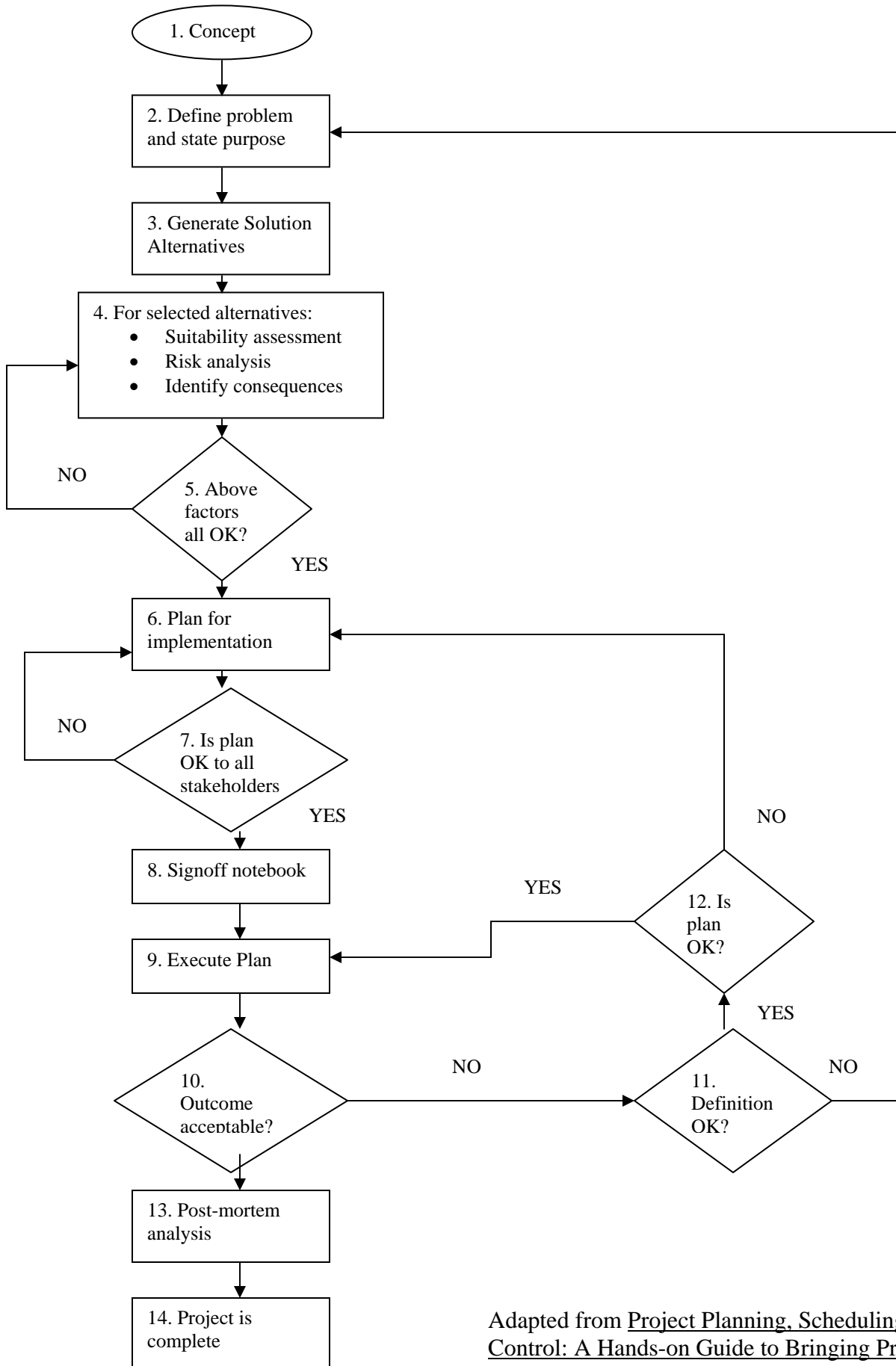

Adapted from Project Planning, Scheduling and Control: A Hands-on Guide to Bringing Projects in on Time and on Budget by James P. Lewis, 1991



## Project Agreement

*This document represents a mutual commitment of time and resources between the XXX and the YYY funding for the fiscal period...*

\_\_\_\_\_ Date

<b>Project Title</b>	<b>Project Number</b>
<b>Faculty Project Lead</b>	<b>Contact Information</b>
<b>Project Manager</b>	<b>Contact Information</b>
<b>Project Start Date</b>	<b>Project End Date</b>
<b>Implementation Date</b>	

### Summary of Project Deliverables

#### ***Project Detail***

The attached Project Schedule, A – G provides a detailed outline of the project rationale and description, deliverables, milestone dates, and specific roles and responsibilities of the project team.

#### ***Accountability***

- It is the responsibility of the School to ensure project faculty are provided sufficient release time to complete the project in a timely manner.
- It is the responsibility of the partners to ensure sufficient project support staffs (technical, administrative, and non-teaching faculty) are available to complete the project in a timely manner. A report on project progress will be submitted to the School and XXX Deans, on request.

#### ***Quality Assurance***

- Project faculty leads are responsible for ensuring that work performed conforms to standards within their professional area of practice, and within the requirements of the School's program area.
- Copyright clearance, where applicable, is the responsibility of the project lead and the School.
- The XXX is responsible for ensuring sound principles of curriculum and instructional design, and, is responsible for providing appropriate standards of editing, graphic and media design support, as applicable.
- ZZ is responsible for ensuring the work performed by the technical staff conforms to accepted professional standards.

#### ***Project Cancellation***

Either party may request suspension or cancellation of the project work with 30 days notice, in writing.

### **A. Project Description/Rationale**

<b>Rationale</b>		
<b>Description</b>		
<b>B. Project Deliverables and Accountabilities</b>		
<b>Design</b>	Project Plan	
	Community of Practice	
<b>Development</b>	Needs analysis	
	Resources	
<b>Implementation</b>	Setting up initial contact with instructors	
	Monitoring and guiding discussions/chat	
<b>Showcase</b>	Article in various sources	
<b>Share</b>	Mentoring/Training other Department Heads on using Communities of Practice to encourage international ties with the institution	
	Sharing research ideas and results	
<b>C. Scope and Other Relevant Information</b>		
<p>This project will encompass the following:</p> <ul style="list-style-type: none"> <li>• Access to course outlines and curriculum materials</li> <li>• Forum for discussion</li> <li>• Resources</li> <li>• The sharing learning materials</li> <li>• The adaptation of materials to the needs of students</li> <li>• Development of teachers' own local, technology-specific teaching materials</li> <li>• Consultations with appropriate groups</li> <li>• Access to related internet links recommended by the Communication Department</li> </ul> <p>This project will not involve any formal training of instructors.</p>		
<b>D. Stakeholders</b>		<b>Level of Involvement</b> (Awareness, provides input, team member, etc.)
School		Team member

XXX	Team member, provides input	
Other Projects (e.g. Faculty Resources)	Provides venue	
Students	Provide input	
<b>E. Project Team Roles and Responsibilities</b>		
<b>Owner and Sponsor</b>	Advocate of project. Has ultimate responsibility for the project, including its priority, funding, achievement of the business objectives, and resolution of critical issues. Member of Core Team.	
<b>Project Lead</b>	Responsible for the overall content, design, development, implementation, showcasing, and sharing (including mentoring) of the project	
<b>Project Manager</b>	Overall project management, coordination, evaluation, teaching and learning practices, academic reviews.	
<b>Technical Advisor</b>	Technical training, advising on the technical capabilities and usability issues of the technology	
<b>Grassroots Coordinator</b>	Responsible for overall coordination of the Grassroots projects; manages the Grassroots Community of Practice; ensures the currency of the Grassroots component of the YYY Initiative Website; arranges orientation for Grassroots project leads	
<b>Academic Portfolio Manager</b>	Allocates adequate funding and resources for academic projects; guides technical aspect of the project	
<b>WCS Portfolio Manager</b>	Allocates adequate funding and resources for the technology component of the project	
<b>Users/Client</b>	Uses, tests learning approaches and the enabling technologies	
<b>F. Milestones and Accountabilities</b>		
<b>Design</b>	Set up CoP (with appropriate rooms) and create Project Plan	Target Date
<b>Development</b>	Communicate with teachers to determine needs, and gather resources from XXX instructors (course outlines, materials, links, etc.	Target Date

<b>Implementation</b>	Teachers enter and participate in CoP	Target Date	
<b>Showcase</b>	Writing an article	Target Date	
<b>Share</b>	Mentoring colleagues with similar international goals	Target Date Ongoing	

**G. Projected Resource Requirements (Days)**

<b>Position/Person</b>	<b>Year</b>	<b>Year</b>	<b>Total</b>
Project Lead			
Project Manager			
IDC			
Technical Advisor			
Project and Documentation Specialist			
Video Team			
<b>Total Days for Project</b>			

[Shade in the appropriate times]

F. Timeline							
TASKS	Notes	Sept	Oct	Nov	Dec	Jan-Mar	April
<b>Design (4 days)</b>							
▪ Decide on tool							
▪ Training: conceptual + hands-on							
▪ Ongoing consultation (outcomes, methodology, website integration)							
<b>Development (5 days)</b>							
▪ Populate (Launch)							
<b>Implementation (6 days)</b>							
▪ Training/support/facilitation for teachers							
▪ Manage the Process							
▪ Collect & tabulate user feedback							
▪ Archiving							
<b>Showcase (3 days)</b>							
▪ Organize and draft article							
▪ Publish Article							
▪ Archive							
<b>Share (2 days)</b>							
▪ Feedback/mentor							

## Project Name

Project Initiation Checklist			
Prepared By:		Date Prepared:	
Revision Number:			
Reference	Identify the source of the request and how it came.		
Project Objective	Expressed as <i>To, in a way that, so that</i> construct		
Background	Briefly describe how this project came about		
Project Scope	What business functions are in and out of scope? What locations are in and out of scope? (attach a Scoping Diagram for clarity) What are the project interfaces? What business procedures are required? What production operations procedures are required? Will an Acceptance Test Plan and testing be required? Will Systems Analysis be required, if so what's needed? What training is required? What documentation is required? What are the critical requirements?		
Constraints	What is the maximum cost of the project? What is the latest project completion date? What are the interproject dependencies?		
Current Issues	Briefly describe any issues that will need to be addressed prior to or during the project		

Organization	
Project Sponsor	Who agrees to this project setup? Who will signoff the requirements? Who will remove obstacles? Who will accept the finished product?
Project Lead	Who will execute the project initiation (e.g., Project Manager or Business Analyst)
Resources & Responsibilities	What additional resources will be required? What are they expected to do?

Schedule	
Start Date	When will the project start?
End Date	When will it end?
Estimate	How many effort hours? How many elapsed hours? What assumptions are you making?
Final Product	What is the end product?
Project Approach	What are the milestones?
Interim Products	What are the products of the milestones?

*Project Initiation Checklist for Small Projects*

---

<b>Business Case</b>	
Project Justification	Why do this project? What happens if we don't do it? Why do it now? How critical will the impact of the project be?
Risks	What could go wrong? (both systems-related and user-related)
Countermeasures	How will you avoid this?
Costs	List all hardware, software, network, staff, facilities and other costs

<b>Project Initiation Approvals</b>			
Requested Date:			
Client Requester:		Date:	
Department Manager:		Date:	
Project Manager:		Date:	
Manager:		Date:	

<http://dijest.com/tools/pmworkbench/pmtemplates/pitempl/PICCHK.DOC>

# PROGRAM DEVELOPMENT

Planning – Implementation – Evaluation

## Program Action - Logic Model

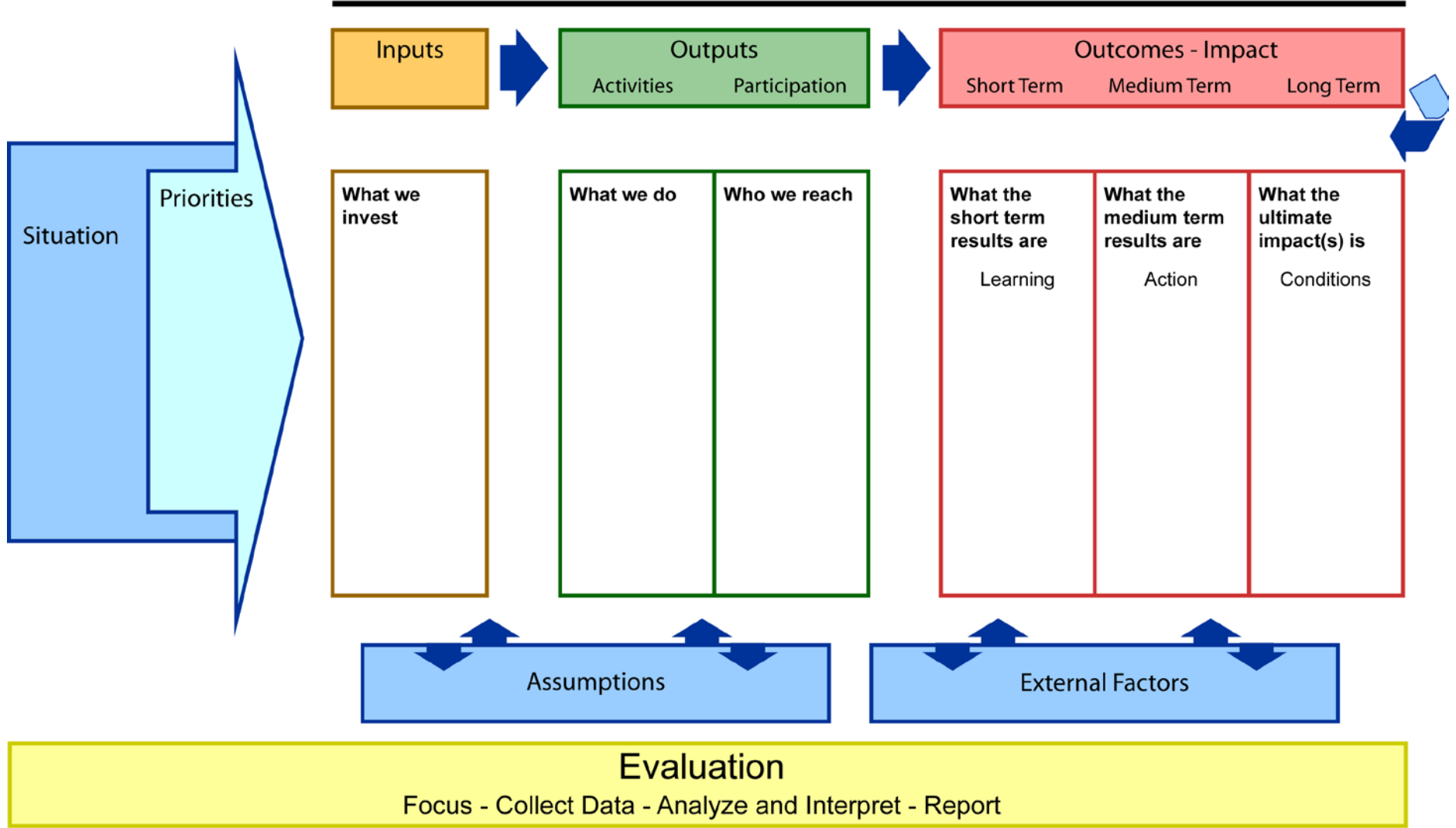



PROJECT NAME  
 Research Project Charter  
 DATE

Charter Members: LIST of NAMES

Principle	Policy
<p>We are interested in disseminating the results of this project as widely as possible, with credit to us for doing it.</p>	<p>Project members may use any of it as examples in presentations, papers, interviews, and other media opportunities. They may post any of it to their web sites. Wherever possible, they should mention the names of the other project members.</p> <p>For presentations or papers where this work is the main topic, all team members should be co-authors. Any member can elect at any time not to be listed as a co-author, but may not veto publication.</p>
<p>We intend this work to move forward at a steady pace, given due awareness of the vagaries of life.</p>	<p>Project members will make every effort to attend meetings as arranged and to keep in regular contact by email or other electronic means. Frequent absence may result in being warned, then cautioned, then asked to leave the team.</p> <p>Project members will jointly establish and attempt to meet self-imposed deadlines; in the event the task is overdue by a considerable amount of time (for instance, double the original timeframe), other members may at their discretion notify the slowpoke that they are going to re-assign the task, without prejudice to the constitution of the team or the public credit of any member.</p>
<p>We would prefer for this work to be funded.</p>	<p>Project members will watch for and notify each other of funding opportunities and participate wherever possible in the writing of appropriate grant proposals.</p>

Signed this day at LOCATION

\_\_\_\_\_ NAME 1

\_\_\_\_\_ NAME 2

\_\_\_\_\_ NAME 3

\_\_\_\_\_ NAME 4

## Interdisciplinary Research Project Charter

Author: Stan Ruecker

PROJECT NAME:

DATE:

Principle	Policy
<p>We are interested in disseminating the results of this project as widely as possible, with credit to us for doing it.</p>	<p>Project members may use any of it as examples in presentations, papers, interviews, and other media opportunities. They may post any of it to their web sites. Wherever possible, they should mention the names of the other project members who were directly involved, as well as the name of the project.</p> <p>The project team will maintain a collaborative project web site, which will contain links to all the presentations and publications of the group.</p> <p>For presentations or papers where this work is the main topic, all team members who worked directly on this subproject should be co-authors. Any member can elect at any time not to be listed, but may not veto publication.</p> <p>For presentations or papers that spin off from this work, only those members directly involved need to be listed as co-authors. The others should be mentioned if possible in the acknowledgments, credits, or article citations.</p> <p>Team members should discuss possible publication venues before submitting abstracts or articles.</p>
<p>We intend this work to move forward at a steady pace, given due awareness of the vagaries of life.</p>	<p>Project members will make every effort to attend meetings as arranged and to keep in regular contact by email or other electronic means. Frequent absence may result in being warned, then cautioned, then asked to leave the team.</p> <p>Project members will jointly establish and attempt to meet self-imposed deadlines, in part through providing the project administrator with lists of commitments, so that reminders will be sent out as a matter of routine.</p> <p>In the event the task is overdue by a considerable amount of time (for instance, whichever is lesser—two months, or double the original timeframe), other members may at their discretion notify the offender that the task will be re-assigned, without prejudice to the constitution of the team or the public credit of any member.</p> <p>Project phases will be arranged so as to minimize the need for sequential completion of one phase before another can begin: wherever possible, phases will run in parallel, with communication occurring between people as they work on each phase, rather than waiting to communicate until the end.</p>
<p>We would prefer for this work to be funded.</p>	<p>Project members will watch for and notify each other of funding opportunities and participate wherever possible in the writing of appropriate grant proposals.</p>



**Simulated Environment for Theatre: Research Project Charter – DRAFT 2**

Adapted from charters by Stan Ruecker and Paul Hjartarson

DATE: 4 October 2012

Principle	Policies
<b>Research Team Collaboration</b>	
<p>We will work collaboratively, because we believe that our collaborative efforts are greater than the sum of their parts.</p>	<p>We will strive for a model of integrated collaboration (as distinct from principal/incidental hierarchy or turn-taking). We look forward to articulating the model as we proceed.</p> <p>All contributors (full researchers, research associates, and research assistants) are team members.</p> <p>Team members will be invited based on their relevant research and technical expertise.</p> <p>We will strive to keep our administrative structure as simple and as “horizontal” (that is, as non-hierarchical) as the needs of the project permit.</p> <p>We will strive for transparency in decision-making and communication.</p> <p>We will strive to keep project administration as malleable and flexible as possible to enable us to respond effectively and efficiently to the many changes development brings.</p>
<p>We strive to describe team members’ roles according to their substantive contributions to the project.</p>	<p>Team roles are typically defined as follows (but remain flexible and available for discussion).</p> <ul style="list-style-type: none"> <li>• Principal Investigator: Administrative and conceptual lead for the purposes of individual funding proposals and grants. Usually a faculty member or eligible member of an accredited institution. No financial compensation, except in the case of commercialization of research results.</li> <li>• Researcher: Co-applicant on grant proposals; long-term, independent conceptual, practical, and administrative contributor to the research project as a whole; leader of an area of core project activity; leads authorship of presentations and papers in his/her field(s) of expertise; contributes to authorship in other areas as requested by the team; responsible for administering sub-grants at home institution; responsible for recruiting and supervising Research Associates and Assistants in his/her field. Usually a faculty member or holder of a relevant terminal degree. No financial compensation, except in the case of commercialization of research results.</li> <li>• Research Associate: Developing an independent research and practical contribution to the project as a whole in association with project Researchers; long-term conceptual and practical contributor to the project; may lead authorship of presentations and papers in his/her area of expertise; may assist in training and/or supervising Research Assistants in his/her field. Usually holds a relevant advanced degree. May</li> </ul>

	<p>receive financial compensation, as well as fees and/or royalties related to commercialization of research results.</p> <ul style="list-style-type: none"> <li>• Research Assistant: Performs research and/or practical tasks as assigned by Researchers and Research Associates. Usually enrolled in a relevant degree program. May receive financial compensation, as well as fees and/or royalties related to commercialization of research results.</li> </ul>
<p>We place a high priority on fostering the development of emerging scholars in all areas (including in the acquisition of collaborative skills).</p>	<p>All team members are invited to participate in conceptual design meetings. (Some administrative meetings are conducted in-camera among Researchers only.)</p> <p>Junior team members are encouraged to stay with the project in the long term, where possible, and to progress through its ranks.</p> <p>Junior team members are offered robust supervision (including iterative design processes and collaborative authorship).</p> <p>Junior team members will be funded to attend and present at project-related conferences whenever possible.</p>
<p>We wish to communicate in such a way as to preserve professional dignity.</p>	<p>We will strive to maintain a tone of mutual respect whenever we write or meet, and to forgive lapses if they occur.</p> <p>We will attempt to keep communications transparent, for example, by copying everyone involved in any given discussion, and by directly addressing with each other any questions or concerns that may arise.</p>
<p>We intend this work to move forward at a steady pace, given due awareness of the vagaries of life.</p>	<p>Project members will make every effort to attend meetings as arranged and to keep in regular contact by email or other electronic means. Frequent absence may result in being warned, then cautioned, then asked to leave the team.</p> <p>Project members will jointly establish and attempt to meet self-imposed deadlines, in part through providing the project administrator with lists of commitments, so that reminders will be sent out as a matter of routine.</p> <p>In the event that a task is overdue by a considerable amount of time (one that threatens to render the project's business unworkable), other members may at their discretion notify the offender that the task will be re-assigned, without prejudice to the constitution of the team or the public credit of any member.</p> <p>Project phases will be arranged so as to minimize the need for sequential completion of one phase before another can begin: wherever possible, phases will run in parallel, with communication occurring between people as they work on each phase, rather than waiting to communicate until the end.</p>
<p><b>Dissemination and Authorship Acknowledgment</b></p>	
<p>We would like our project to be documented for our own and future researchers' reference and benefit, and to assist with future funding opportunities.</p>	<p>Documentation is meant as a support; therefore, documentation responsibilities will be kept to a minimum amount possible (so that the work can be done) while ensuring that a sense of the project's development is recorded (so we can see where the project has been).</p>

	<p>We will document our work as it arises from the rhythms of the project. Forms of documentation include meeting notes; development “tickets”; white papers; copies of presentations; publications, and course materials developed; and so on.</p> <p>A task is not completed until the documentation is shared.</p> <p>All documents, including working documents, generated by the group are always accessible to current group members.</p> <p>In addition to PDFs or other formats for presentation, project members will keep safe and distribute regularly all native files generated for the project: source code, Photoshop, Illustrator, Flash, InDesign, and any other data files or source files. These files will be unflattened and editable. Where copyright restrictions do not apply, fonts should also be included in shared files.</p> <p>Insofar as ethics clearances allow, data backup will be provided through central project servers. Local projects should also make provisions for regular backup of all project files, including versions of files in progress.</p>
<p>We are interested in disseminating the results of this project as widely as possible, in a manner that reflects the interdisciplinary nature of our work, with credit to all contributors.</p>	<p>All team members are credited as authors of all project products.</p> <p>The SET system itself is authored by PI (or PIs, when more than one grant is current); Researchers and Research Associates (alphabetically) with Research Assistants (alphabetically).</p> <p>White Paper, Presentation, and Publication authorship contributions fall into the following categories:</p> <ul style="list-style-type: none"> <li>• Lead Author: responsible for the bulk of the conceptualization, research, and drafting of the research product. There may be more than one Lead Author of a paper.</li> <li>• Co-Author: responsible for a secondary contribution to conceptualization, research, and drafting of the research product; for example: preparation of figures, drafting short passages of text, design and/or implementation of the element of the project under discussion.</li> <li>• Contributing Author: responsible for collaborative foundational project work and, optionally, comments on and/or minor edits to the research product.</li> <li>• Research Assistants: follow the above after the word “with”.</li> <li>• Corporate Author: under certain circumstances - for example, when a disciplinary journal cannot accommodate a full list of authors, or where “spin-off” research (see below) is being published – a corporate author may be cited as follows: the Simulated Environment for Theatre project.</li> <li>• Sequence is normally: Lead (alphabetical); Co (alphabetical); Contributing (alphabetical); “with” Research Assistants.</li> </ul> <p>Project members may use any of our work as examples in presentations, papers, interviews, and other media opportunities. They may post any of it to their web sites. Wherever possible, they should</p>

	<p>mention the names of the other project members who were directly involved, as well as the name of the project.</p> <p>The project team will maintain a collaborative project web site, which will contain links to all the presentations and publications of the group. All participants will be listed on the project website, including dates and roles; the website provides an ongoing record of contributors and contributions.</p> <p>Any member can elect at any time not to be listed as an author, but may not veto publication.</p> <p>Team members should discuss possible publication venues before submitting abstracts or articles.</p>
Our open-source research products	?
<b>Funding and Compensation</b>	
The normal Tri-Council policies apply to our financial compensation structure.	Faculty in accredited institutions are not eligible for compensation, except in the case of commercialization of research products. Professional consultants, technical assistants, research associates, and research assistants are eligible for compensation, according to the guidelines articulated at administering institutions.
We would prefer for this work to be funded.	<p>Project members will watch for and notify each other of funding opportunities and participate wherever possible in the writing of appropriate grant proposals.</p> <p>Project members will assist in record-keeping and reporting the use of funds as appropriate.</p>
We will strive for equitable distribution of research funds to all contributing researchers.	<p>Researchers will be consulted about the appropriate distribution of funds.</p> <p>Funds will be distributed based on the tasks to be completed under each researcher's supervision.</p> <p>Consideration will be given to meaningful funding (for tenure and promotion purposes) at each institution.</p>
Commercialization	<p>Members will also watch for and notify each other of opportunities for commercialization and licensing.</p> <p>Any commercial agreements or plans will be made so as to include and appropriately benefit all members of the group (even members who are no longer active at the time of commercialization).</p> <p>We may consider a model whereby proceeds of commercialization are folded back into the project budget and/or the research budgets of individual faculty project researchers and research associates.</p>

<b>Continuity</b>	
<p>We embrace the fact that some of our project's contributions to knowledge may be unexpected and tangential.</p>	<p>Spin-off research is research inspired by, but not directly related to our project. (Such as, for example, our Cambridge model and our research on the Canadian theatrical canon).</p> <p>The products of spin-off research may be used in SET project activities if they become relevant, provided proper acknowledgement is given to non-SET contributors.</p> <p>Spin-off research will be funded to the extent that project resources allow. Eligible expenses include Research Assistants' and Associates' wages, travel expenses, and research and dissemination costs.</p> <p>In the dissemination of spin-off research, only those project members directly involved need to be listed as authors. The others should be mentioned if possible in the acknowledgments, credits, or article citations, or as corporate authors.</p>
<p>We hope that the work we do on this project may have future phases.</p>	<p>Modifications and additions may be made to further the project by any member.</p> <p>We anticipate two broad categories of project development:</p> <p>Collaborations with other projects:</p> <ul style="list-style-type: none"> <li>• Involve work contributing to our current project goals OR</li> <li>• Involve an exchange of intellectual property with another research project OR</li> <li>• Involve the development of new intellectual property in collaboration (for a description of which, see above) with another project</li> </ul> <p>New phases of the current project:</p> <ul style="list-style-type: none"> <li>• Are defined collaboratively by the current research team</li> <li>• Extend and adapt the current project's goals</li> <li>• As the project progresses to new phases, each team member will have the right of first refusal over whether or not to continue with the project.</li> </ul> <p>Project development does not:</p> <ul style="list-style-type: none"> <li>• involve the initiation of entirely new goals</li> <li>• refer to work building on our current published research products, which could be undertaken by any researcher outside our team</li> </ul>
<b>Involvement of Students in Research</b>	
	<p>Students are engaged as paid research assistants only, and do not contribute coursework to project research.</p>

Signed this day at \_\_\_\_\_

Location

\_\_\_\_\_



Signature

Name

---

Signature

Name

---

Signature

Name

---

Signature

Name

---

Signature

Name

**DRAFT EMiC UA PROJECT CHARTER**  
**FIRST (RYERSON CONFERENCE) ITERATION**  
(revised November 9, 2011)

Trust Cluster Principles and Policies

**Collaboration**

Principle #1: We will work collaboratively, that is, we want and need to learn from one another.

Principle #2: As a DH “collaboratory” in a university setting, we place a high priority on fostering graduate student development in all areas (including in the acquisition of collaborative skills).

Principle #3: Collaborators are people who sign the charter, that is, membership in EMiC UA is defined by an individual’s acceptance of the principles, policies and practices of the collaboratory.

Policy: Research assistants are encouraged to sign the project charter when they begin their work with EMiC UA and thus become collaborators. They are also encouraged to expand their participation in the collaboratory beyond simply putting in their hours.

Policy: Research assistants are eligible for EMiC UA and EMiC Dal funding to attend DEMiC and TEMiC and to present conference papers as part of one or more of the project groups.

Principle #4: We will strive to keep the administrative structure of the collaboratory as simple and as “horizontal (that is, as non-hierarchical) as the needs of the project permit.

(The principle here is the less bureaucracy the better. The untested assumption is that, mentoring apart, collaboration thrives in the absence of hierarchy.)

Policy: Given the developmental nature of the work EMiC UA is undertaking, the administrative structure of the collaboratory should be kept not only simple and non-hierarchical but as malleable and flexible as possible to enable us to respond effectively and efficiently to the many changes development brings.

Principle #5: We will work within schedules and to deadlines arrived at collaboratively.

Principle #6: All collaborators have the right of first refusal on ensuing stages of the project.

**Credit**

Principle #1: All work undertaken to advance EMiC UA projects is equally deserving of credit. (Giving credit speaks to the ethos of the project itself).

Policy: EMiC UA will be credited as an organizational author on all publications; we will additionally use author listings, notes, and acknowledgements as differing levels for attributing credit on our work.

Policy: All participants will be listed on the project website, including dates and roles; the website provides an ongoing record of contributors and contributions.

Principle #2: We recognize the need for credit as a part of academic advancement. (This follows from our commitment to mentoring and to our support for the completion of academic programs as part of EMiC UA project work.)

## **Documentation**

Principle #1: Collaboration is rooted in good, clear documentation, both as a means of understanding one other's work and as a means of distributing credit.

Principle #2: Documentation is necessary not only for the purpose of informing other group members and continuing workflow but in support of grant applications and reports.

Principle #3: We will document our work as it arises from the rhythms of the project. (Documentation will be geared around project planning, dissemination and reporting.)

Principle #4: A task is not completed until the documentation is shared. The primary site for documentation is the wiki.

Principle #5: Documentation is meant as a support; therefore, documentation responsibilities will be kept to a minimum amount possible (so that the work can be done) while ensuring that a sense of the project's development is recorded (so we can see where the project has been).

Principle #6: All documents, including working documents, generated by the group are always accessible to current group members.

## **Communication**

Principle #1: We will strive for transparency in decision-making and communication.

Principle #2: We will strive to disseminate our work as widely as possible, and we will strive to reflect the interdisciplinary nature of our work in the way we disseminate it.

Principle #3: We will strive to produce open source code & style sheets whenever possible

Lynne Siemens & Ray Siemens

*University of Victoria*

Richard Cunningham

*Acadia University*

Teresa Dobson

*University of British Columbia*

Alan Galey

*University of Toronto*

Stan Ruecker

*Illinois Institute of Technology*

Claire Warwick

*University College London*

## Abstract

This document reflects the distributed administrative structure to be put into practice by the Implementing New Knowledge Environments (INKE) group for the purpose of governing itself as it carries out work on its Major Collaborative Research Initiative (MCRI)-funded initiative. The INKE group consists of academic researchers, academic research partners (many invested as stakeholders as well), an international advisory board, a partners committee, individual research area groups (RAG) each with their own (co)leads who act as administrators for the group and form the overall RAG administrative group committee, and an executive committee (EC) that represents all areas of activity in the research endeavour and also includes an administrative/management advisor (who carries out work and provides leadership on process, not research content) and a project manager. Taken as a whole, the structure of the group is an embodiment of the distributed administrative and authoritative principles that have evolved over the several years of the project's foundation, and the materials that follow have been assembled and authored by the entirety of the administrative team in that spirit. This document is also closely aligned with the processes outlined in two related documents: the annual calendar and the annual RAG planning process.

## Keywords

INKE; Administration; Research; Collaboration

CCSP Press

*Scholarly and Research Communication*

Volume 3, Issue 1, Article ID 010113, 21 pages

Journal URL: [www.src-online.ca](http://www.src-online.ca)

Received August 17, 2011, Accepted November 15, 2011, Published March 26, 2012

Siemens, Lynne, Siemens, Ray, Cunningham, Richard, Dobson, Teresa, Galey, Alan, Ruecker, Stan, & Warwick, Claire. (2012). INKE Administrative Structure: Omnibus Document. *Scholarly and Research Communication*, 3(1): 010113, 21 pp.

© 2012 Lynne Siemens, Ray Siemens, Richard Cunningham, Teresa Dobson, Alan Galey, Stan Ruecker, & Claire Warwick. This Open Access article is distributed under the terms of the Creative Commons Attribution Non-Commercial License (<http://creativecommons.org/licenses/by-nc-nd/2.5/ca>), which permits unrestricted non-commercial use, distribution, and reproduction in any medium, provided the original work is properly cited.

Lynne Siemens is an Assistant Professor in the School of Public Administration at the University of Victoria, 3800 Finnerty Road, Victoria, BC, Canada V8N 1M5  
Email: [siemensl@uvic.ca](mailto:siemensl@uvic.ca)

Ray Siemens is Canada Research Chair in Humanities Computing and Distinguished Professor in the Faculty of Humanities in English with cross appointment in Computer Science at the University of Victoria, PO Box 3070 STN CSC, Victoria, BC, Canada V8W 3W1  
Email: [siemens@uvic.ca](mailto:siemens@uvic.ca)

Richard Cunningham is an Associate Professor in the Department of English and Theatre, as well as Director at Acadia Media Centre at Acadia University, 15 University Avenue, Wolfville, NS, Canada B4P 2R6  
Email: [richard.cunningham@uacadia.ca](mailto:cunningham@uacadia.ca)

Teresa Dobson is an Associate Professor in the Department of Language and Literacy Education and Director of the Digital Literacy Centre at the University of British Columbia, 2329 West Mall Vancouver, BC, Canada V6T 1Z4  
Email: [teresa.dobson@ubc.ca](mailto:teresa.dobson@ubc.ca)

Alan Galey is an Assistant Professor in the Faculty of Information at the University of Toronto, 27 King's College Circle, Toronto, ON, Canada M5S 1A1  
Email: alan.galey@utoronto.ca.

Stan Ruecker is an Associate Professor at the Institute of Design, Illinois Institute of Technology, 350 North La Salle Street, 4th Floor, Chicago, IL, USA 60610  
Email: sruecker@id.iit.edu

Claire Warwick is Professor of Digital Humanities and Head of the Department of Information Studies; Director of the UCL Centre for Digital Humanities; and Vice-Dean for Research for the Faculty of Arts and Humanities at the University College London, Gower Street, London, UK WC1E 6BT  
Email: c.warwick@ucl.ac.uk

*The INKE Research Group comprises over 35 researchers (and their research assistants and postdoctoral fellows) at more than 20 universities in Canada, England, the United States, and Ireland, and across 20 partners in the public and private sectors. INKE is a large-scale, long-term, interdisciplinary project to study the future of books and reading, supported by the Social Sciences and Humanities Research Council of Canada as well as contributions from participating universities and partners, and bringing together activities associated with book history and textual scholarship; user experience studies; interface design; and prototyping of digital reading environments.*

### Preamble

This document reflects the distributed administrative structure to be put into practice by the Implementing New Knowledge Environments (INKE) group for the purpose of governing itself as it carries out work on its initiative funded by Major Collaborative Research Initiative (MCRI). The INKE group consists of:

1. academic researchers,
2. academic research partners (many invested as stakeholders as well),
3. an international advisory board,
4. a partners committee,
5. individual research area groups (RAG) each with their own (co)leads who act as administrators for the group and form the overall RAG administrative group committee, and
6. an executive committee (EC) that represents all areas of activity in the research endeavour and also includes an administrative / management advisor (who carries out work and provides leadership on process, not research content) and a project manager. Taken as a whole, the structure of the group is an embodiment of the distributed administrative and authoritative principles that have evolved over the several years of the project's foundation, and the materials that follow have been assembled and authored by the entirety of the administrative team in that spirit.

Ultimately, this document represents an agreement we have made with each other for how we will work together in pursuit of achieving the goals outlined in our research application, in recognition of the fact that the research funding is not made to specific individuals but, rather, to the group as a whole—on the basis that we as a group will make every attempt to follow the plans we have made to date.

This document is also closely aligned with the processes outlined in two related documents: the annual calendar and the annual RAG planning process.

### LIMITATIONS

We note that we are doing something different here from typical small-group or individually-oriented Humanities research. Given the nature of the process used to originate what is manifest in this document, it is not surprising that some of the structures and even understood roles that are found in this document are defined in

ways that are at a slight departure from the Social Sciences and Humanities Council (SSHRC) definitions – even though, in most cases, they reflect consultation with SSHRC guidelines, best practices (manifested in the MCRI program review), and the input of a number of external consultants including past MCRI directors and leaders and the research offices of a number of involved institutions. The INKE administrative team understands this, and the definition of roles and their interoperation is an attempt to augment those laid out by SSHRC. We realize, however, that ultimately we are in a position where, if the roles we have defined and the patterns of interoperation we've outlined fail, we must necessarily revert to our funding agency's definitions and prescribed patterns of operation.

#### CONCERNS, CONFLICTS, AND GRIEVANCES

As noted in the document, these issues are handled in via the line of authority laid out in the document. Concerns of this nature among the administrative group are handled through an email to the EC, via the director; the director will then circulate that email to the rest of the EC. Open communication is valued in INKE. Attempts to retain anonymity will be made only on request, and it cannot be guaranteed that these attempts will be successful.

#### NEXT STEPS, AT TIME OF ORIGINATION

This document has and will see evolution as follows:

1. tentative adoption of its operating principles at the 10 March 2008 INKE administrative meeting (which allows us to begin planning work for Year One);
2. non-substantive editing by the project manager in March with substantive suggestions flagged for discussion by the administrative group at the end of March and possible revision reflecting the outcome of that discussion;
3. reflection on the document and the operation it enables at a meeting of the administrative group in late May, and possible revision (including input by SSHRC and others at the April administrative meeting); and
4. discussion among the administrative group toward recommending its full acceptance by the EC at that committee's first meeting (with provision for discussion/revision of the document at each EC meeting, to ensure that there is a process to change the document and what it represents). This document was accepted by the EC on May 24, 2009.

#### Statement of management and administrative operations, from the application

To achieve our goals, this integrated program of research requires careful management to sustain collaboration and co-ordinate all research initiatives, as diagrammed below (arrows indicate the flow of discussion and contribution) and described as follows

- an *executive committee*, comprised of Siemens (as director), and a lead representative from each of the research sub-area groups (Cunningham, Warwick, and Ruecker), plus *ex officio*, the chair of the advisory board, and the chair of the partners committee, the project manager, our administrative/management advisor, and a student research assistant representative;

- an international *advisory board* of approximately 3-5 experts in the areas engaged by our work, to be invited from among a named pool;
- a *partners committee*, representing our stake-holding research partners; and
- a *sub-area research administrative structure*, comprised of the leaders of each sub-area's research group and (in this way) representing all researchers and students involved in the project, and including Galey and Cunningham for Textual Studies (TS), Warwick for User Experience (UX), Ruecker for Interface Design (ID), and Siemens for Information Management (IM).

This structure privileges the contributions of each group, foregrounding the demands of the research and functioning bi-directionally.

Figure 1: INKE Supporting Administrative Structure

In this structure, research groups operate under the detailed project plan from which this document is derived, and which has been developed in conjunction with our administrative and organizational advisors. Operations are carried out according to a project charter developed and agreed upon by the entire team. Integration and co-

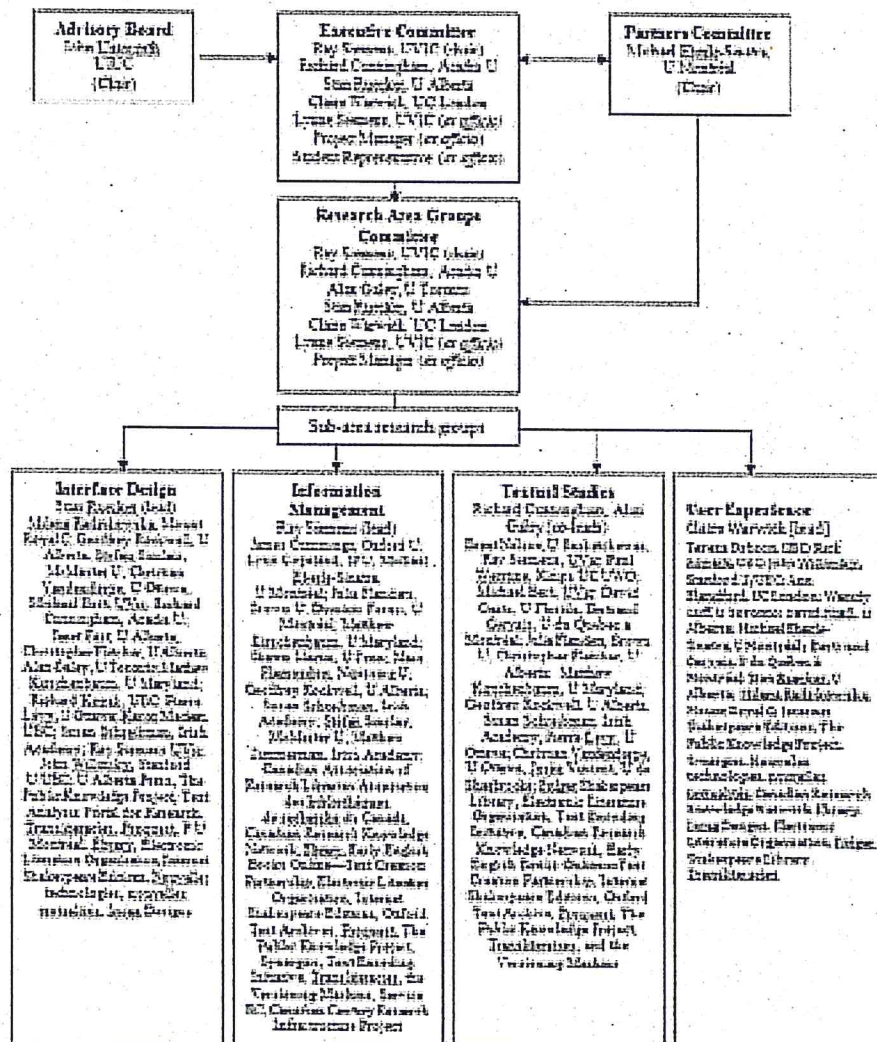

ordination, as well as oversight of work consistent with the project plan, take place in conjunction with the sub-area research administrative structure, the EC, the advisory board, and the partners committee. Representatives of the research area administrative structure meet via teleconference monthly, and the EC, the advisory board, and the partners committee meet by teleconference during the year as needed; each group meets in person at least once annually, with the exception of the advisory board. The EC will act as trustees of the project's research direction and of the research budget, working in consultation with members of the advisory and partners groups, approving the release of research funds (via subcontract structure, and in consideration of our research plan) to individual areas and researchers based on an annual reporting cycle which includes evaluation of past work and next-stage work projection and budgeting. E-mail discussion groups will be established for each section management group, all researchers, and for postdoctoral and research assistants. Our management, administrative, and research structures support best practices identified in the SSHRC MCRI program performance report (Kishchuk, 2005), and the advisor to our administrative, management, and team research practices will play an integral part in identifying, introducing, supporting, and studying/evaluating the positive impact of these practices on our work.

### Researchers

INKE researchers are:

- academic researchers, with active research involvement in the INKE program of research;
- individuals representing a research partner, with active research capacity in INKE; or
- listed as co-investigators, collaborators, or the principal investigator (PI) on the grant application, and may also include
  - postdoctoral fellows, and graduate and undergraduate research assistants (defined in the context of our funder, which is Canadian), hired with INKE funds to work on the project; and
  - with the agreement of RAG and the executive committees, they may also be researchers brought in via other funding mechanisms which directly contribute to INKE research.
- differentiated from consultative researchers and partners, who:
  - offer invaluable expertise, advice, and research materials, playing a consultative role in the intellectual direction and conduct of the research, and
  - are not actively involved in INKE grant-funded research, but may be involved in adjacent or related research activities, including other grant-funded research in which members of our research team are involved.

As a member of the INKE research team, all researchers

- are under the direction of team leaders, contribute to achieving the goals outlined in INKE's research plan, and articulated subsequently by the INKE EC, RAG committee, and team leaders;
- abide by the principles and practices laid out in the INKE charter;
- abide by the SSHRC and Tri-Council policies on the use of grant funds and on the use of human subjects in research, as well as the regulations of their local institutions;
- receive named co-authorship credit on presentations and publications that make direct use of research in which they took an active, as opposed to passive,



- role (i.e., research to which the individual made a unique and discernable contribution with a substantial effect on the knowledge generated); otherwise, receive indirect credit via the INKE corporate authorship convention;
- use INKE resources, including human resources and travel funds, only in the pursuit of INKE's research objectives, and with the approval of Research Area Team Leaders;
  - suggest opportunities for dissemination of INKE project prototypes and other research results;
  - receive direction upon request from any member of their sub-area research team, researcher or partner, provided the request is identified as pertinent to the research of the sub-area research team (the research environment is both collaborative and integrated, and this is intended to augment existing patterns of communication);
  - co-ordinate publications and presentations on INKE research through their team leaders, and provide electronic copies of all submitted paper drafts, presentations (including materials like PowerPoint presentations), abstracts, and reader reports to team leaders for deposit with INKE management and archival system;
  - respect the confidentiality of unpublished INKE materials (including source code) and expect the confidentiality of their own unpublished materials to be respected in return; the agreement surrounding this and other related concerns are found in the INKE Intellectual Property statement below; and
  - wherever possible seek publication venues that support open-access or conjoint publication, recognizing that having INKE research published in prestigious venues is no less desirable.

More specifically, those who are listed as co-investigators on the INKE application are expected to:

- make a significant contribution to the intellectual direction of the research, play a significant role in the conduct of the research, and may also have some responsibility for financial management of the research;
- meet with their sub-area research team leaders, and possibly other INKE researchers at the same time, via teleconference, Skype, or video-conference once per month (or as needed in exceptional circumstances) to (1) set research goals, responsibilities, and timelines in accordance with the broad research schedule established in the INKE grant text, (2) articulate the aforementioned in a detailed research plan, (3) report on progress and on milestones attained and articulate these in quarterly progress reports, and (4) ensure the transmission of work from one team to another in accordance with stipulated deadlines plus coordinate dissemination activities;
- meet with at least one of their team leaders in person once per year, or as needed in exceptional circumstances, preferably at conferences where all parties would normally be in attendance, and where it is convenient to so meet; the purpose of this meeting is to discuss research-related concerns;
- interview, hire, and supervise postdoctoral fellows and research assistants in consultation with team leaders and following executive-approved research plans for their areas;
- as appropriate, provide mentoring and collaborative opportunities for postdoctoral fellows and research assistants, and whenever possible seek funding to bring postdoctoral and graduate assistants to major INKE meetings and conference presentations;

- provide research area leaders with reports that itemize completed research tasks, note any dissemination relating to the research, provide the names of post-doctoral and graduate student personnel and the duration of their employment, and detail the funding and training opportunities provided to those individuals; they will also provide other reports on work-in-progress, and otherwise, as need for the project and as requested by the project managers or others in the project administration; and
- upon voluntarily leaving the INKE project, or upon being asked to leave, relinquish their claim to all INKE funds, resources, and credit for subsequent work undertaken by the team.

Postdoctoral fellows, graduate and undergraduate assistants:

- follow the direction of their immediate supervisor in carrying out INKE research and, when appropriate, consult with team leaders directly;
- receive mentoring as requested from their supervisors and other INKE researchers, especially in matters of professionalization and related issues; partners and collaborators may help with this process as well; and
- receive credit for significant contributions to INKE's research; significance will be determined by the line of report.

#### INTELLECTUAL PROPERTY

Those working with INKE understand the value of conjoint collaboration in INKE's research commons (methodological and informational), and understand:

1. that the material (of any kind, and in any media) a researcher brings to INKE as part of their research involvement will become part of INKE's research commons and remain among the material that INKE researchers may continue to draw upon in INKE work, with full acknowledgment of INKE and the originating researcher;
2. that, should a researcher leave INKE, the material of the research commons (of any kind, and in any media) that was not explicitly in the leaving researcher's origin can continue to be used in that researcher's own research only with the explicit written permission of the INKE EC, and then it can only be used with full acknowledgment to INKE and the original researcher;
3. INKE will retain first right of refusal for publication and commercialization of any work that the researcher undertakes with the INKE research commons;
4. that all INKE researchers will use the work of others -- including those in the INKE group, and in the research commons -- with full acknowledgment of that work's origins; and
5. that those who make use of INKE materials of any kind, disseminated in any media and via any dissemination principles, do so with full acknowledgment of that work's origins.

For presentations or papers where this work is the main topic, all team members should be co-authors. We will adopt the convention of listing the team itself, so that typically the third or fourth author will be listed as "INKE Research Group," while the actual named authors will be those most responsible for the paper. The individual names of members

of the INKE Research Group should be listed in a footnote, or where that isn't possible, through a link to a web page. Any member can elect at any time not to be listed, but may not veto publication. For presentations or papers that spin off from this work, only those members directly involved need to be listed as co-authors. The others should be mentioned if possible in the acknowledgments, credits, or article citations.

It is noted that grievance, conflict, and other concerns will be handled via a line of authority structure, a line of authority structure, from graduate assistant (GRA)/research assistant/postdoctoral fellow to researcher to research area leader in the RAG structure to EC via the director, with those above in the line of authority copied on all documentation of the issue and its resolution. For example: if a GRA has demonstrated an inability to carry out their assigned responsibilities, the GRA will be warned by their immediate researcher, who will at the time of warning forward documentation, by e-mail, of problem areas and direction for improvement, copying by email that documentation to the RAG team leader and the director. A researcher may be dismissed or asked to resign if he or she continues to demonstrate an inability to carry out the foregoing responsibilities; in the case of dismissal, the research area leader, in conjunction with the INKE EC, will issue formal notice including a detailed justification in writing. Suspension of duties pending appeal will be effective immediately.

### **Research Area Groups Committee (RAG)**

Sub-area research groups form the backbone of INKE's research and administration. RAG leaders report to, and take direction from, the EC via the project director; members of Sub-Area Research Teams (researchers) report to RAG committee through their Sub-Area Research Team Leader(s). RAG leaders, established via the research application planning process, are active researchers themselves with administrative oversight of the work carried out in their research teams. They

- comprise a group of sub-research area leaders, including the Project Director, who serves as Chair. Members of the RAG committee are responsible for co-ordinating and overseeing research in each of the following four research areas: Textual Studies, User Experience, Interface Design, and Information Management. The members of RAG and their respective areas of responsibility are as follows:
  - Interface Design: Dr. Stan Ruecker, English and Film Studies, University of Alberta
  - Information Management: Dr. Ray Siemens, English, University of Victoria.
  - On Leave: Dr. Susan Schreibman, Digital Humanities Observatory, Royal Irish Academy.
  - Textual Studies: Dr. Richard Cunningham, English, Acadia University and Dr. Alan Galey, Faculty of Information, University of Toronto
  - User Experience: Dr. Claire Warwick, Department of Information Studies, University College London
- have active representation on the EC, as per the terms of that committee
- carry out operations with respect to what is outlined in the annual calendar, the annual RAG planning process documents, and the project charter, and
- meet with their respective research area teams (as per the researchers section of this omnibus document)

- via teleconference, Skype, or videoconference once per month, or as needed in exceptional circumstances, to (1) set research goals, responsibilities, and timelines in accordance with the broad research schedule established in the INKE Grant text, (2) articulate the aforementioned in a detailed research plan, (3) report on progress and on milestones attained and articulate these in quarterly progress reports, and (4) ensure the transmission of work from one team to another in accordance with stipulated deadlines plus co-ordinate dissemination activities
- in person once per year, or as needed in exceptional circumstances, preferably at conferences where most members would otherwise be in attendance, and where it is convenient to so meet
  - with the chair of the meeting responsible for the agenda and carrying out commensurate reporting (including minuting) to the EC, via the project administrative space
- as a group
  - via teleconference, Skype, or videoconference at least once per month, or as needed in exceptional circumstances, to (1) set research goals, responsibilities, and timelines for respective sub-groups, (2) review and synchronize the detailed research plans of each Research Area Team, (3) report on progress and milestones attained, and (4) ensure the integration and transmission of work from one team to another in accordance with stipulated deadlines
- in person at least once per year, or as needed in exceptional circumstances, preferably at conferences where most members would otherwise be in attendance, and where it is convenient to meet
  - with the chair of the meeting, typically the director, responsible for the agenda and carrying out commensurate reporting (including minuting) via the project administrative space; decision-making by consensus first, then by straight vote; quorum is more than 50% of the voting members
  - co-ordinate, integrate, oversee research and research reporting, and co-ordinate communication and dissemination in their respective areas, entailing
    - writing, in consultation with team members and others, a detailed annual research plan explaining how INKE research goals will be accomplished and submitting this plan to the EC in order to acquire INKE research funds – all as reflected in the planning process
    - ensuring document or data exchanges between research area sub-groups according to the annual research plans
    - distributing funds to researchers, after approval of the research plan and budget by the EC (funds and research contracts to be coordinated at the University of Victoria, by the research office via the project manager);
    - liaising with relevant partners in order to ensure research integration and exchange;
    - undertaking dissemination activities and provide direction upon request from any member of their sub-area research team, researcher or partner, provided the request is identified as pertinent to the research of the sub-area research team (as per the researcher description);
    - handling RAG reporting duties, which require them to

- receive and review Research Reports from individual active researchers (defined in the previous section) that itemize completed research tasks, note any dissemination relating to the research, provide the names of post-doctoral and graduate student personnel and the duration of their employment, and detail the funding and training opportunities provided those individuals;
- synthesize material in a fashion consistent with these Research Reports with a view to submitting Sub-Area Team Reports to the project administrative space on a quarterly basis, and include in that additional materials required by the MCRI reporting structure;
- present Research Area Team Reports in RAG committee meetings and inform researchers and partners of published reports on a quarterly basis;
- organize activities relating to the sub-area conference in the year specified in the INKE Grant text, including
  1. arranging hosting, advertising, assuming program chair (or co-chair) duties, and making local arrangements for the event;
  2. editing the sub-area research team research volume emerging from the aforementioned conference in accordance with the timeline stipulated in the INKE Grant text;
  3. disseminating (including publishing and presenting) INKE work within and beyond the academic community according to the presentation and publication schedule outlined in the INKE Grant text and in the year-by-year project plans for each area,
    - recognizing that, like researchers who leave the project, if they leave the project (for whatever reason) they relinquish all rights to the research and research products of the INKE team, and sole rights to those they created themselves with INKE funding.

The foregoing are the minimum responsibilities expected of members of the RAG committee. Other considerations follow.

- *Conflict of interest:* any arising potential conflict of interest situations should be reported to the EC via the director. In situations where conflict of interest is identified, the individual in the conflict of interest must remove him/herself from decision making, though will have the opportunity to propose a course of action for the remaining members of RAG (or other pertinent administrative entities) to consider.
- *Exiting the project:* In the event that a member of RAG anticipates being unable to fulfil his or her duties for a foreseeable amount of time (for example, a sabbatical leave), he or she must make a formal request for a leave of absence to the EC in writing, outlining steps taken to ensure that RAG administrative duties are carried out during this time. If the leave is granted, the RAG leader may recommend a replacement, or that no replacement be sought. If granting such a leave is deemed to be a detrimental to the continuity of the INKE project

(as determined by the EC), the EC may ask the RAG leader in question to consider either continued work in a reduced capacity or resignation.

- *Grievance or conflict*: These will be handled via a line of authority structure, from research area leader(s) in the RAG structure to the EC via the director, with those above in the line of authority copied on all documentation of the issue and its resolution. Decisions relating to grievance or conflict will be handled by the EC. Should this arrangement prove insufficient, the director will seek advice on how to handle the situation in consultation with some or all of the chair of the advisory board, the chair of the partners committee, the University of Victoria research office (which is the institutional point of contact for SSHRC) and SSHRC MCRI officer. Grievance or conflict settlement may result in a request for leave, resignation, or dismissal, in which case policies associated with the appropriate request will be enacted.
- *Resignation*: Any member of the RAG can resign from the RAG committee at any time, without formal statement of cause, and in doing so recognizes that they do so in the knowledge that they leave ongoing (and resultant) research/budget planning in the hands of the EC (which represents all research areas). Notice of one full annual research cycle is required.
- *Inability to carry out duties*: If any member of the RAG committee demonstrates an inability to carry out the foregoing responsibilities, this situation will be handled via a line of authority structure, from research area leader(s) in the RAG committee structure to EC via the director, with those above in the line of authority copied on all documentation of the issue and its resolution. A RAG leader may be dismissed or asked to resign by the EC if he or she continues to demonstrate an inability to carry out the foregoing responsibilities; in case of dismissal, the EC will issue formal notice including a detailed justification in writing. Suspension of duties pending appeal will be effective immediately, and those dismissed are asked to recognize that they leave ongoing (and resultant) research/budget planning in the hands of the EC (which represents all research areas) – though, situation permitting, every attempt will be made to ensure that the dismissed member will not lose status as a researcher, nor lose access to research monies
  - Appeal: Appeal processes must be initiated within 30 days of notification. If an appeal is not initiated within this timeframe, it will be understood that the individual has accepted the decision of the EC.
- The EC, through the project director, will relay news of any such changes to those who are impacted by those changes.

### **Researchers and research partners/Associate researchers and associate research partners**

Partners in our research – individual researchers, research teams, and larger groups and entities of several types – play integral roles in INKE in advisory, consultative, active research, and associative capacities. At INKE's inception, consultations involved building research relationships with individual researchers in key areas of endeavour and partner groups in the stakeholder areas most pertinent to our program of research.

### **RESEARCHERS**

With researchers, this has ensured appropriate representation and expertise in areas key to our anticipated work. INKE's initial researcher network was established in

the time leading to the application to the MCRI program, and includes Ray Siemens (University of Victoria), Richard Cunningham (Acadia University), Teresa Dobson (University of British Columbia), Alan Galey (University of Toronto), Stan Ruecker (University of Alberta), Susan Schreibman (Irish Academy), Claire Warwick (University College London), Michael Best (University of Victoria), Ann Blandford (University College London), Lynn Copeland (Simon Fraser University), James Cummings (University of Oxford), Wendy Duff (University of Toronto), Michael Eberle-Sinatra (University of Montréal), Janet Fast (University of Alberta), Julia Flanders (Brown University), Christopher Fletcher (University of Alberta), Dominic Forest (University of Montréal), David Gants (University of Florida), Bertrand Gervais (Université du Québec à Montréal), Matthew Kirschenbaum (University of Maryland), Richard Kopak (University of British Columbia), Pierre Lévy (University of Ottawa), Alan Liu (University of California at Santa Barbara), Karon Maclean (University of British Columbia), Shawn Martin (University of Pennsylvania), David Miall (University of Alberta), Brent Nelson (University of Saskatchewan), Marc Plamondon (Nipissing University), Milena Radzikowska (Mount Royal College), Geoffrey Rockwell (University of Alberta), Lynne Siemens (University of Victoria), Stéfán Sinclair (McMaster University), Christian Vandendorpe (University of Ottawa), Josée Vincent (Université de Sherbrooke), Paul Werstine (King's University College, University of Western Ontario), John Willinsky (Stanford University and University of British Columbia), and Matthew Zimmerman (Irish Academy).

#### PARTNERS

With partners, these relationships ensure our direct involvement in essential stakeholder areas, including: general and scholarly publishing (together with open-access publication); public and academic libraries; educational software development; computing science and information management; standards development for electronic texts; disciplinary departments in the humanities; professional readers; and members of the reading public. Partners also play an important role in the technology transfer associated with the prototypical computing interfaces that INKE will produce; by participating in ongoing discussion about and planning of the research program, and by indicating how such work might best serve interests beyond those of pure research, all partners will continue their own pioneering efforts in the areas engaged by our work. INKE's initial partnership network was established in the time leading to the application to the MCRI program, and includes the Canadian Association of Research Libraries / Association des bibliothèques de recherche du Canada, the Canadian Century Research Infrastructure project, the Canadian Research Knowledge Network, Ebrary, Early English Books Online, Text Creation Partnership, the Electronic Literature Organisation, the Folger Shakespeare Library, Incaa Designs, the Internet Shakespeare Editions, Nouvelles technologies / nouvelles textualités, the Oxford Text Archive, Presses de l'Université de Montréal, Proquest, the Public Knowledge Project, Service BC (BC Provincial Government), Synergies, the Text Encoding Initiative Consortium, Transliterations, the Versioning Machine, and University of Alberta Press.

#### EXISTING TYPES OF RESEARCHERS AND PARTNERS

Non-exclusive categories of researcher and partnership involvement have since inception included:

- Advisory: providing input into discussions of pertinence to our research and its program, at times requested;
- Consultative: advisory involvement on a longer term basis (through our consultative structures) and/or involvement in research-related activities like, among others, production and dissemination, also providing resources for these and other activities (including data); and
- Active: engaged in carrying out research activities with the INKE team, contributing both significant research time and, possibly, other resources of their own.

#### **NEW: ASSOCIATE RESEARCHERS AND ASSOCIATE RESEARCH PARTNERS**

Since receiving news of the award, INKE has learned to recognize that one function of MCRI program funding is for MCRI groups to function as a locus of research activity in areas of MCRI funding, creating an identifiable research network around this locus—and, by extension, it can be seen as a mission of our group to create possibilities in this direction as well.

Associate researchers and associate research partners, two newer types of INKE researcher and partner, can be seen as an essential part of this activity. Associate researchers and partners can fall into any of our non-exclusive partner categories, providing that they meet the appropriate criteria and follow the process of admission outlined below.

#### **ASSOCIATE RESEARCHERS AND ASSOCIATE RESEARCH PARTNERS: PROCESS FOR ADMISSION, AND CRITERIA FOR ASSESSMENT**

Advisory and consultative associate researchers and partners have research and stakeholder agendas with key elements that are closely aligned with INKE's research agenda, and can contribute in meaningful ways to INKE's agenda and that of the communities INKE engages. Active associate researchers and partners fit similarly, and more specifically:

- are groups whose research agenda has key elements that are closely aligned with INKE's research agenda;
- have a fully funded program of research they will complete independent of INKE funding, but have clearly defined areas of research confluence such that we could imagine there being readily apparent efficiencies in use of our own resources if we draw them into our active research network (and there is explicit commitment of their resources in this direction as well, requiring verification); and
- understand the nature of the allied research endeavour as INKE has articulated it across its administrative research structure, and agree to operate within the framework specified by INKE's governance documents.

The process of admitting an associate researcher or partner is handled via a detailed letter of request, and pertinent appendices, to the EC on behalf of the researcher or partner, and submitted as a single package by one of the RAG leaders as champion for that potential associate. This letter makes the case for partnership employing the terms of the category of association being requested. Since requests for association will be seen to be particularly desirable in areas where INKE teams recognize a particular need for partner representation, this should be addressed in the letter as well. Further, a number of pertinent details about the pragmatics of that association must be documented in the letter and via attachments to the letter before the process of admission can proceed, including



1. the name of the associate, affiliation (academic and group, if pertinent), contact information (surface mail, phone/fax, and electronic), and CV of research lead;
2. the project title and description, plus URL;
3. the total number of researchers involved in the association/number who will be involved in INKE-allied activities (these must be named);
4. the total amount of research resources involved (funding, and in-kind)/amount of research resources that will be involved in INKE-allied activities; and
5. indication that the associate acknowledges and understands the terms and conditions of association as outlined in the document, and documents referred to in this document.

The decision for admission of association lies with the EC, in consultation with the chair or all of the partners committee and possibly other members of the RAG committee, and will be handled in as timely a fashion as the schedule of the EC allows.

### **Partners Committee**

The main role of the partners committee, as described in the research application, is in representing our stake-holding research partners in the work carried out by INKE.

#### **WHAT DOES THE CHAIR OF THE PARTNERS COMMITTEE DO?**

- Attends regular meetings of the INKE EC
- Serves as one means of bringing partner ideas, issues, and concerns to the attention of the INKE EC
- Meets at least once a year (in person or virtually or if possible at other venues where committee members will already be present) with other members of the Partners Committee to update them on project progress and to learn their thoughts
- Ensures the participation of the Partners Committee in the annual planning cycle, reviewing and commenting upon materials presented to them

#### **WHAT DO MEMBERS OF THE INKE PARTNERS COMMITTEE DO?**

- Represent INKE stakeholding research partners, and assist in documenting the research flow in both directions (from partners and to partners)
- Meet at least once a year (in person or virtually or if possible at other venues where committee members will already be present) to discuss partner ideas, issues, and concerns
- Discuss opportunities for dissemination of INKE project prototypes and other research results
- Advise the Chair on issues to bring forward to the INKE EC
- Propose and discuss opportunities for shared research activities with the INKE team, providing recommendations to the INKE EC
- Advise the INKE EC on establishing clear criteria for considering new partners, beyond those partners established in the application phase, and provide advice to the INKE EC on the addition of new associate partners

- The committee will be comprised of a minimum of three and maximum of five partner representatives, including the Chair, each of whom serve for a term of three years, renewable with approval of the committee and the EC; ideally, representation will be equitable across the four thematic areas of the grant, and take into account other distributions as well
- The EC establishes the membership of the partners committee, in consultation with the RAG members and current committee membership. Each partner organization may suggest to the director a representative to serve on the committee, acknowledging that appointment is made by the EC.
- Partners and their representatives may choose to be identified as:
  - Active: sharing in research activities with the INKE researchers
  - Donating: providing data or other resources
  - Production: attempting further development and dissemination of INKE prototypes or ideas
  - Consultative: providing input to discussions

### **The International Advisory Board (IAB)**

Serves as a consultative body for the INKE group

- bringing knowledge and skills to INKE that are complementary to the knowledge and skills of members of the EC, the Partners Committee, and the Project's Administrative structure of Research Area Groups
  - making recommendations and/or providing key information and materials to INKE, primarily via the EC, but holding no formal authority to govern INKE nor to issue directives
  - is comprised of members invited by the EC, in consultation with RAG committee members, for three years (renewable terms), and complies with the following criteria
- they must be able to
  - meet as a group in person or via teleconference, Skype, or videoconference, etc. with the INKE EC not less than once per year, or as needed in exceptional circumstances
  - assist the INKE project by making others within their professional sphere aware of it
  - provide advice and insight relative to the project vision and strategic direction
  - provide information on the needs and views of our stakeholders
  - provide links to communities, businesses, organizations, and government agencies
  - join members of the INKE project for meetings or advisory consultations at conferences where the IAB member is otherwise in attendance, and where it is convenient to so meet, and be generally accessible to INKE-affiliated people, provided the request is channelled through a member of the Administrative structure and is identified as pertinent to INKE
- the IAB will ordinarily have five members, one of whom will serve as Chair, though it may have as few as three members at any given time, of which
  - no member will be in a position to receive funds from INKE, nor will any member of the IAB be a partner or a member of a partner organization.
  - members of the IAB will bring unique knowledge and skills to the governance structure of INKE at pertinent stages of our work. Given this, it is anticipated

that membership will change as the project enters different phases. It is expected that those with the most experience and expertise in starting large projects will form the IAB initially. Those with experience and expertise in enhancing and ensuring communication and mid-term productivity will form the IAB subsequently. And those with expertise and experience in wrapping up and assessing large projects will form the IAB latterly.

- IAB members can resign at any time, without formal statement of cause. Any member of the IAB who chooses to resign must notify the INKE EC via written letter of resignation to its chair. It shall be the responsibility of the EC to notify other members of such action.
- The chair of the IAB ensures actions of the board in accordance with the above, and ensures the participation of the IAB in the annual planning cycle and necessary meetings.

The foregoing are the minimum responsibilities expected of members of the IAB and of the INKE EC relative to each other. The IAB is understood to have no further responsibilities to the INKE Project, nor any of its members as pertains to the INKE Project, except as they may agree to as the project progresses. The EC is understood to have no further responsibilities to the IAB or members thereof, except as may develop as the project progresses. The aforesaid notwithstanding, the EC is understood to have duties and responsibilities to the INKE Project beyond those articulated in this document.

#### **Executive Committee**

The Executive Committee (EC) is comprised of Ray Siemens (as project director, and chair of the committee), and a lead representative from each of the research sub-area groups (Richard Cunningham (TS), Claire Warwick (UX), Ray Siemens (IM), and Stan Ruecker (ID), plus *ex officio* the chair of the advisory board, the chair of the partners committee, the project manager, our administrative/management advisor, and a student research assistant representative. The EC has the following duties, working roughly as captured by the information above:

- Works in consultation with the Advisory Board, Partners Committee, and the research area groups (RAGs) through its internal representational structure:
  - membership is drawn from the leadership of the RAGs and represents that group through the EC's internal representational structure
  - takes advice from the Advisory Board, as outlined in that board's mandate, and ensures the function of that board in accordance with that board's mandate; it also appoints members of this board and its chair, in consultation with the RAG leaders and current Advisory Board members, and in the understanding that they are able to perform the duties of the board as outlined in this document; the EC also calls the meetings of this group
  - works with the Partners Committee, as outlined in that committee's mandate, and ensures the function of that committee in accordance with that committee's mandate; it also appoints members of the committee and its chair, in consultation with the RAG leaders and current Partners Committee members, and in the understanding that they are able to perform the duties of the committee as outlined in this document; the EC also calls the meetings of this group

- acts as the chief point of contact between all parts of our governance structure (including the research team) and our funding agency on issues relating to INKE, through the Chair
- acts as trustee of the project's research direction and of the research budget:
- At the annual meeting, it approves the release of research funds to research area sub-groups and its researchers, based on an annual reporting cycle, which includes evaluation of past work and next-stage work projection and budgeting. Internal reporting, management, and planning remain the role of the research sub-area groups. Decision making is minuted, and all actions that are not able to be handled by consensus will be passed by majority vote of the voting members.
- It releases funds via a subcontract structure with RAG leaders and researchers, and in consideration of the research plan and fulfillment of annual planning and reporting structures. In all but exceptional cases, it releases 75% of funds at the outset of the annual research plan, and the remaining 25% at point of review of successful completion; the only exceptional case noted is that of the requirements of University College London (UCL) accounting system.
- Operates under similar conflict-of-interest guidelines in decision-making as SSHRC. Specifically, this is in reference to discussion of, and voting on, research sub-area groups' reports, research plans, and budget proposals. Here, we invite the EC representative of the RAG to present and answer questions relating to reports, research plans, and budget proposals, but leave the room for committee discussion and voting; in cases where this applies to the Director, a deputy will be appointed to chair this part of the EC meeting's proceedings.
- Meets in person once a year, with provision for teleconferencing for some members at this time. Meets by teleconference throughout the year, as needed, called by the Director. A majority of voting members must be present for quorum to be reached, though it is understood that it is preferable for all members of this committee to be present at meetings.
- Is the top of the line of authority structure that governs the relationships in our administrative structure and handles grievances and complaints, and acts as the chief authority on issues of INKE dissemination, the chief contact point for SSHRC and the media, is responsible for gathering materials relating to reporting and other administrative cycles of the grant; and, through the Director, is responsible for the project manager, being the project manager's direct report.

The EC must be in a position to respond to demands of the funding agency, further details of which will become evident at the April 2009 meeting of the Program Officers at the University of Victoria. It must ensure that all structures – management, administrative, research, and otherwise – support best practices identified in the SSHRC MCRI program performance report (Kishchuk, 2005; [http://www.sshrc-crsh.gc.ca/about-au\\_sujet/publications/mcri\\_performance\\_e.pdf](http://www.sshrc-crsh.gc.ca/about-au_sujet/publications/mcri_performance_e.pdf)) and the advisor to our administrative, management, and team research practices will play an integral part in identifying, introducing, supporting, and studying / evaluating the positive impact of these practices on our work. Related documentation, if any is required, may include the following; this could also be handled by extension of this document:

- discussion of the role of the project Director/PI, as this role might deviate from what is documented in the SSHRC guidelines.

- documentation of the fact that our administrative structure is more broadly-based than other MCRI administrative structures, distributing some elements of typical 'Director' leadership across a larger group, in this case the EC and the RAG committee.
- notice that SSHRC will expect to interact with our group as they do with others, and will expect the Director to act in a role akin to their definition of that role. (We will be expected to meet that expectation, regardless of the structure we put into place. This should only be an issue if our administrative structure proves not to be effective.)

### Project manager relationships:

- Reports to the Executive Committee through the Project Director
- Through the Project Director, takes direction from the Executive Committee and the RAG administrative group
- Is *ex officio* member (non-voting) of Executive Committee
  - Responsibilities:
    - General support and oversight on full-project specific matters. These include:
    - Co-ordinating reporting on (by providing means for the admin group to report on)
    - Research area research plans
    - Research area budgets and overall budget
    - The status of integrated research work at regular intervals
    - Co-ordinating, handling and facilitating internal and external communication (via listservs, project website, blogs, wikis, etc.)
    - Administering the project budget
    - Providing secretariat functions for the Advisory Board, Executive Committee, and Partners Committee
    - Coordinating with university and partner research offices and other university departments at the administrative level (research communication will be handled by the administrative group)
    - Providing research and communicative data management support for the whole project, as well as individual research areas
    - Providing advice on area project plans and reports
    - Providing coordination and direct support for the University of Victoria events
    - Managing the local research lab

### Funding agency

We note, as well, the involvement of the funding agency in our work, including

- The agency itself, which sets the general targets for our work and its impact in its program descriptions (see <http://www.sshrc-crsh.gc.ca/funding-financement/programmes-programmes/mcri-gtrc-eng.aspx>)
- the adjudication committee (and reviewers, working via the adjudication committee) who have provided recommendations for us to implement in our work (found in documents provided by the SSHRC adjudication committee and program officer)
- the mid-term evaluation committee, who will ensure that our work meets the burden of the program and of the promise of our research application (criteria available from the SSHRC MCRI program officer)
- the MCRI performance report, which outlines best practices (see Kischuck, 2005).

### Stakeholders and the general public (from the grant application)

Note: This is section 8 of the grant application. Full reflection of how we have discussed integrating stakeholders is spread across the application. Our list of partners was constructed by identifying stakeholder areas, then building research relationships with groups representing key stakeholder areas. Thus, representatives of stakeholder areas pertinent to our work manifest themselves as involved research partners – having committed to our cluster collaborations and shaped the program of research we propose here; this group remains as per our earlier application. While participating in discussion about the research program for the past three years, and by indicating how such research might best serve interests beyond those of pure research, those involved have also continued their own pioneering efforts in the areas engaged by our work and promise to do so as our work together continues. Another important role our stake-holding research partners will play is in the technology transfer associated with the prototypical computing interfaces for books and electronic book objects that our work will produce; many are in the position of developing and bringing out the prototypes for widespread use. We wish especially to highlight the fact that our work is likely to have a very broad stakeholder community: from the general and professional reader to Kindergarten to Grade 12 education to the corporate world of information technology and design. In 2007, we organized a symposium involving both academic and corporate presenters (including representatives of Microsoft Research and Hewlett Packard Labs) and as a result were invited by Microsoft Research to present a position paper on our work at the BooksOnline'08 Workshop at CIKM (Warwick, C., Siemens, R., Ruecker, S., & the INKE team, 2008). Our research is known and of interest to some of the most well known international information technology corporations, and we plan to expand their knowledge of our work via further research-related activities such as these symposiums, and further with indirectly affiliated groups such as NINES (Networked Infrastructure for Nineteenth-century Electronic Scholarship), the Digital Library Foundation's Aquifer Project, IBM's Many Eyes Project, MONK (Metadata Offer New Knowledge), and SEASR (Software Environment for the Advancement of Scholarly Research). Stakeholder areas essential to our work include those in: general and scholarly publishing (including open-access publication); public and academic libraries; educational software development; information management and computing science; standards development for electronic texts and other materials; government agencies; Kindergarten to Grade 12 and university education; humanities and social sciences disciplines; professional readers; and members of the reading public, who read online. Beyond these, specific impacted areas also include those, worldwide, in:

- *General Public & Industry*: information architects; information managers; web designers; journalists; librarians; teachers; publishers; professional readers and writers; artists; administrators; lawyers; doctors; and managers.
- *Members of Academic Units in Universities*: academic libraries; archives; book history; classics; communications; computer science; distance education; education; English; film and new media studies; fine art and design; history; languages; linguistics; offices of learning technologies; philosophy; psychology.
- *Members of Academic Associations*: Association for Canadian College and University Teachers of English; Modern Language Association and its press; Association for Literary and Linguistic Computing; Association for Computers and the Humanities;

International Reading Association; International Society for the Empirical Study of Literature and Media; National Reading Conference; National Council of Teachers of English; Society for the History of Authorship, Reading, and Publishing; Society for Textual Scholarship; Society of Archivists (UK); Chartered Institute of Library and Information Professionals (UK); American Library Association; American Society for Information Science and Technology.

- *Members of Open Community Organizations, and those they impact*: Open Source Initiative; Creative Commons; GNU Project.

### Project Charter

PROJECT NAME: INKE

Research Project Charter

DATE: 7 July 2009.

This charter is to be understood within the context of the administrative governance documents and the INKE grant. It is subject to review and update by majority vote of the admin leaders.

### Principles

1. We are interested in disseminating the results of this project as widely as possible, with credit to us for doing it.
2. We will move the work forward according to the research schedule that we are committed to SSHRC to deliver, including the various timelines/milestones, budgets, students, and activities described in the INKE grant.
3. We would prefer for this work to generate further projects that can also be funded.
4. We will ensure that everyone on the project has access not only to our research results, but also to our working documents.
5. We wish to communicate in such a way as to preserve professional dignity.
6. We will guide ourselves by reference to the SSHRC MCRI best practices document, which is entitled *PERFORMANCE REPORT: SSHRC's Major Collaborative Research Initiatives (MCRI) Program*
7. We will strive for transparency in decision making and communication.
8. We will actively involve our organizational partners in the project.
9. We will try to take this opportunity to learn more about project management of large teams.
10. We would like to foster goodwill among all the participants.
11. We will work collaboratively.
12. We will support the development of graduate students in content expertise and collaborative skills.

13. We will recognize both individual and shared intellectual property.

14. We acknowledge that time commitments should remain manageable for all participants.

## References

Kishchuk, Natalie. (2005). *Performance Report: SSHRC's Major Collaborative Research Initiatives (MCRI) Program*. Ottawa, ON: SSHRC. URL: [http://www.sshrc-crsh.gc.ca/about-au\\_sujet/publications/mcri\\_performance\\_e.pdf](http://www.sshrc-crsh.gc.ca/about-au_sujet/publications/mcri_performance_e.pdf) [January 5, 2009].

SSHRC. (2011). *Major Collaborative Research Initiatives*. Ottawa, ON: SSHRC. URL: <http://www.sshrc-crsh.gc.ca/funding-financement/programs-programmes/mcri-gtrc-eng.aspx> [16 January 16, 2011].

Warwick, Claire, Siemens, Ray, Ruecker, Stan, & the INKE team. (2008). *Codex Redux: Books and New Knowledge Environments. Books Online 2008 workshop. ACM 17th Conference on Information and Knowledge Management (CIKM 2008) Napa Valley, California*. New York, NY: ACM.





# Network Logic Diagram

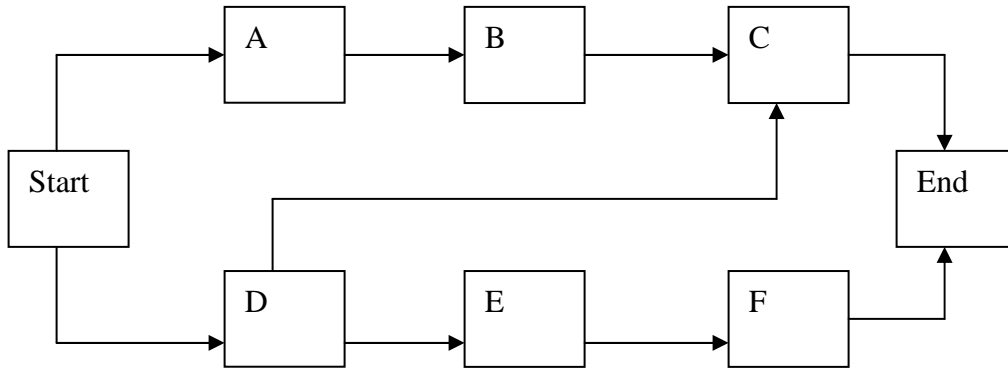

# Project Network Diagram with Scheduled Dates

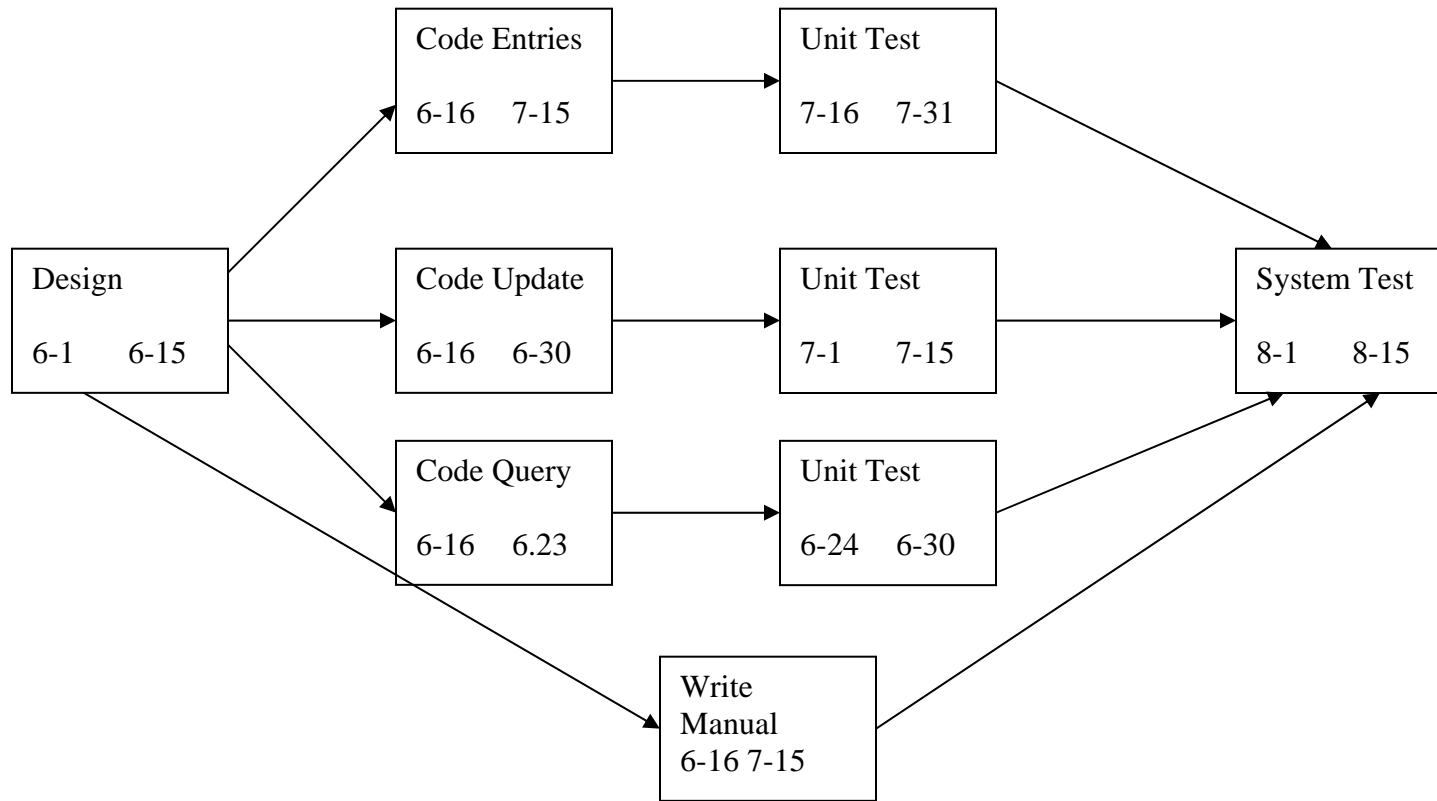

Gantt Chart

		Jan				Feb				March				April			
		1	2	3	4	1	2	3	4	1	2	3	4	1	2	3	4
Task	Duration																
1	1 month	█	█	█	█	█	█	█	█								
2	2 month			█	█	█	█	█	█	█	█						
3	.5 month				█	█											
4	1 month						█	█	█	█	█						
5	.5 month												█	█			
6	1 month													█	█	█	█

Gantt Chart with milestones

		Jan				Feb				March				April				
		1	2	3	4	1	2	3	4	1	2	3	4	1	2	3	4	
Task	Duration																	
1	1 month	█	█	█	█	█	█	█	█	▲								
2	2 month			█	█	█	█	█	█	█	█	█	▲					
3	.5 month				█	█												
4	1 month						█	█	█	█	█							
5	.5 month												█	█				
6	1 month													█	█	█	█	▲

▲ Due Date

# Project Timeline

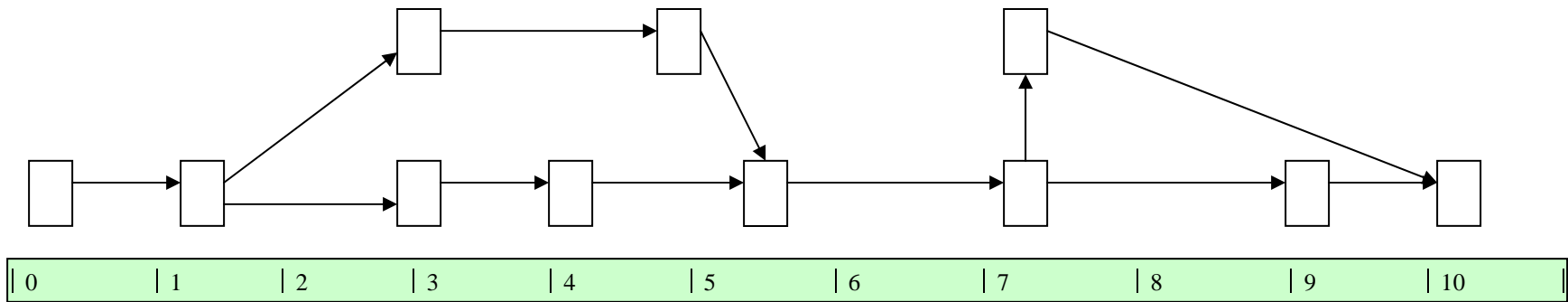

## Project Plan Approval

Project Plan Approval		
Project Description	Project Code	Date
From	Department	Return by:
Your signature below indicates that you agree with the plan submitted so far as your interests are concerned.		
Approving Individual	Signed	Date
Functional Managers		
Directors		
Project Manager		
Outside Stakeholders		
Comments		

Lewis (1995) Project Planning, Scheduling and Control: A Hands-On Guide to Bringing In On Time and On Budget, Probus Publishing Company.

Gantt Chart

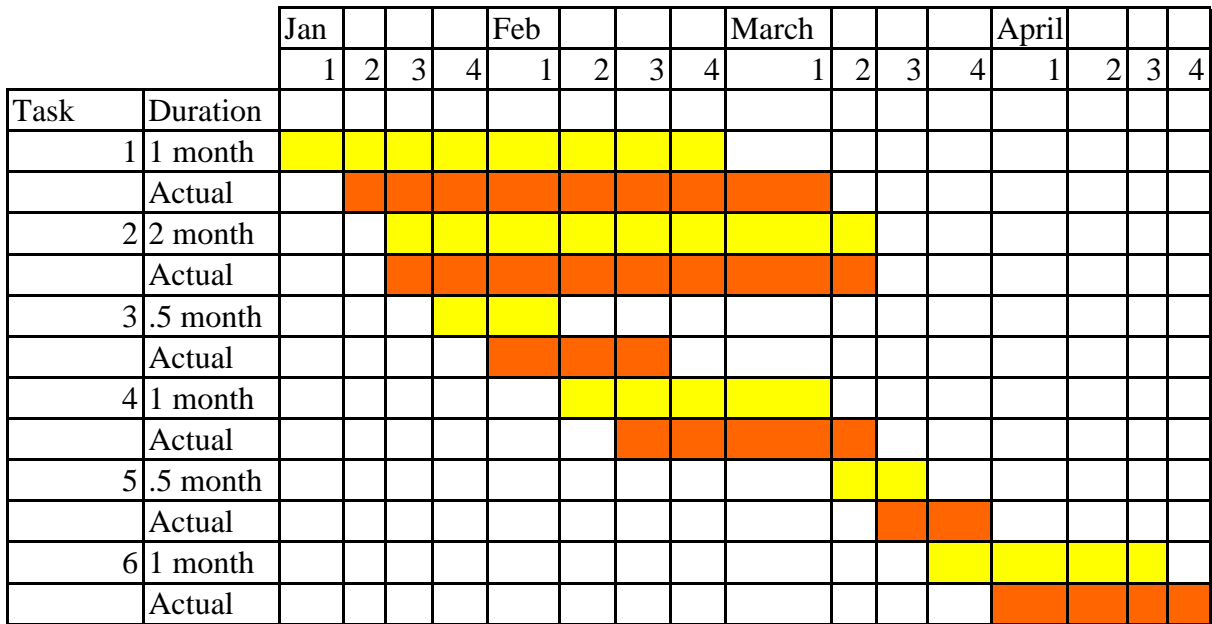

Gantt Chart with milestones

Gantt Chart

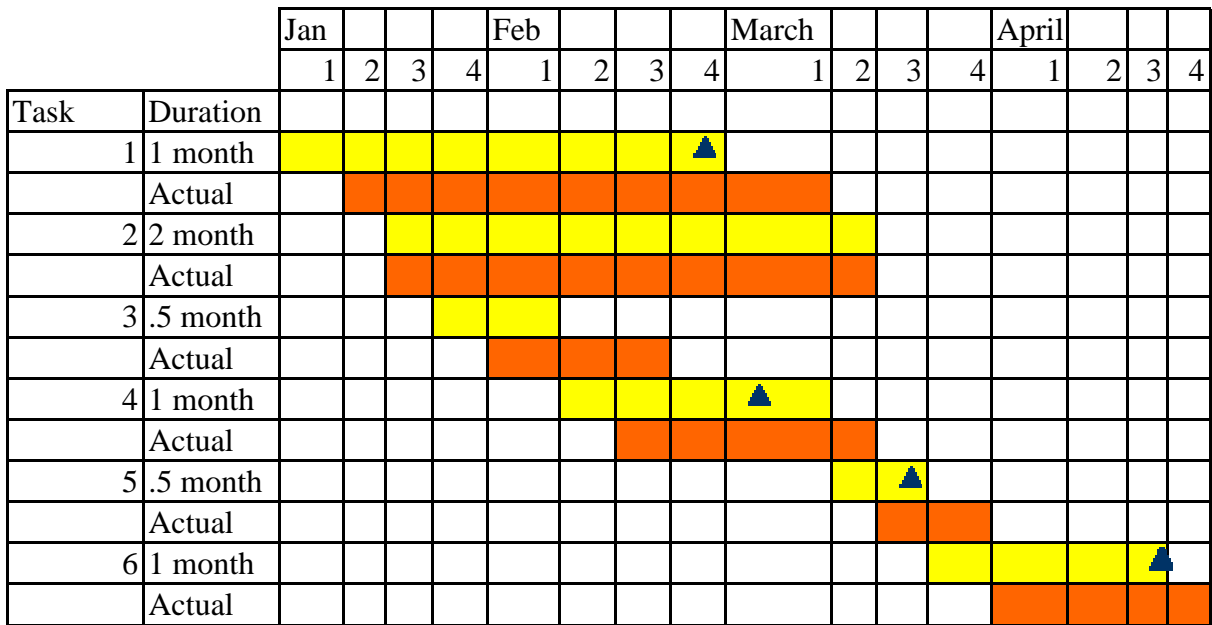

▲ Due Date

## Budget Control

WBS Element	Budget	Actual Cost	Cost Variance	
			\$	%
Pre Pilot Planning	63000	62500	500	0.79%
Draft Checklists	64000	46800	17200	26.88%
Curriculum design	23000	23500	-500	-2.17%
Mid-term evaluation	68000	72500	-4500	-6.62%
Implementation support	12000	10000	2000	16.67%
Manual of Practice	7000	6000	1000	14.29%
Roll Out Plan	20000	18100	1900	9.50%
Totals	257000	239400	17600	6.85%

Adapted from Figure 10-3, page 110

A Guide to the Project Management Body of Knowledge, PMI Institute, 1996



**Change Control Log** (Adapted from Project Management: How to Plan and Manage Successful Projects by Joan Knutson and Ira Bitz, AMACOM, 1991.)

Change Control Number	Date Submitted	Description of Change	Department	Telephone Extension	Date Required	Status

**Change Control Form** (Adapted from Project Management: How to Plan and Manage Successful Projects by Joan Knutson and Ira Bitz, AMACOM, 1991.)

<p>Part 1 – Requester Name: Date: Description of Change:  Benefits:</p>
<p>Part 2 – Change Controller  Change Number: Date Received:</p>
<p>Part 3 – Change Control Committee  Disposition: (cancel or continue) Date: Signatures: Project Manager:</p>
<p>Part 4 – Investigation Team  Assigned to: Date: Impact:</p>
<p>Part 5 – Approval Committee Disposition: (cancel or continue) Date: Priority: Signatures: Department Manager: Project Manager: Other:</p>

<http://dijest.com/tools/pmworkbench/pmtemplates/pctempl/CCFORM2.DOC>

## Change Request Form

Request No:	Request Date:
Request Title:	Status:
Originator's Name:	Phone/Email/ Mailstop:
Sponsor's Name:	Priority:
Assigned To:	Response Date:

### Request Description

### Justification

### Alternative Solutions

- 1.
  
- 2.
  
- 3.

**Impact Assessment**

<b>Impacts</b>	<b>Option 1</b>	<b>Option 2</b>	<b>Option 3</b>
Functional Scope			
Schedule			
Effort			
Cost			

**Recommendation**

--

**Authorization**

Action:

Authorized By:

Date:



# Project Board Progress Review Meeting

MM/DD/YY  
 1:30 PM to 3:00 PM  
 Building 790, Monterey

Meeting called by:  
 Type of meeting:

Facilitator:

Attendees:  
 Please read:  
 Please bring:

## Agenda

Status & Achievements Project Manager 1:30-1:40 PM

Discussion:

---



---

Conclusions:

---

Action items:

Person responsible:

Deadline:

Upcoming Milestones & Adjustments Project Manager 1:40-1:50 PM

Discussion:

---



---

Conclusions:

---

Action items:

Person responsible:

Deadline:

Cost & Staffing Review		Project Manager	1:50-2:00 PM
<u>Discussion:</u>			
<u>Conclusions:</u>			
Action items:	Person responsible:	Deadline:	
Change Requests		Project Board	2:00-2:20 PM
<u>Discussion:</u>			
<u>Conclusions:</u>			
Action items:	Person responsible:	Deadline:	
Major Issue Resolution		Project Board	2:20-2:40 PM
<u>Discussion:</u>			
<u>Conclusions:</u>			
Action items:	Person responsible:	Deadline:	
Business Case Review		Project Sponsor	2:40-2:50 PM
<u>Discussion:</u>			
<u>Conclusions:</u>			
Action items:	Person responsible:	Deadline:	

Teaming & Meeting Management

Project Manager

2:50-3:00 PM

Discussion:

Conclusions:

Action items:

Person responsible:

Deadline:

**Additional Information**

Special notes:



# Monthly Project Status Report

General Information:	
Agency name:	Date:
Contact Name:	Phone:
Project ID:	For the period beginning: and ending:
Name of the project:	
Project Start Date:	Current Phase:

## Key Questions

- 1) Has the project scope of work changed? Yes/No
- 2) Will upcoming target dates be missed? Yes/No
- 3) Does the team have resource constraints? Yes/No
- 4) Are there issues that require management attention? Yes/No

If any of the above questions is answered "yes", please provide an explanation of the "yes" answer.

### Key Milestones for the Overall Project revised on <date>:

Milestone	Original Date	Revised Date	Actual Date

### Milestones Planned for this month and Accomplished this month:

Milestone	Original Date	Revised Date	Actual Date

**Accomplishments Planned for this month and not completed:**

Milestone/Item/Accomplishment	Original Date	Revised Date
1)		
2)		
3)		
4)		

For each item listed above, provide a corresponding explanation of the effect of this missed item on other target dates and provide the plan to recover from this missed item.

**Items Planned for Next Month:**

Milestone	Original Date	Revised Date

*(Use a chart like the following to show actual expenditures compared to planned levels. Break the costs into other categories as appropriate.)*

Year-to-Date Costs (000)				
Fiscal Year	Actual Costs to Date	Estimate to Complete	Total Estimated Costs	Total Planned Budget
20__				
Personnel Services				
Prof. & Outside Service				
Other Expenditures *				
Total Costs				

*(Use a chart like the following if this project spans more than one fiscal year.)*

**Year-to-Date Costs (000)**

<b>Grand Total For Project</b>	<b>Actual Costs to Date</b>	<b>Estimate to Complete</b>	<b>Total Estimated Costs</b>	<b>Total Planned Budget</b>
------------------------------------	-------------------------------------	---------------------------------	--------------------------------------	-------------------------------------

Personnel Services

Prof. & Outside Service

Other Expenditures \*

Total Costs

**\* Other Expenditures include hardware, software, travel, training, support, etc.**

*Attach the current risk list.*

*Attach the current issues/action item list (for the significant items that need management attention)*

<http://www.dir.state.tx.us/eod/qa/monitor/status.htm>

## Checklist for Managing Projects

- A clear, concise statement defining the project has been prepared and reviewed by knowledgeable parties for consensus.
- Performance criteria have been developed. These criteria are measurable and specific.
- A work breakdown structure has been developed to a level sufficient to prepare accurate estimates of costs, resources, and working times for all project activities.
- A statement of project scope that clearly defines the limits of what will and will not be done has been developed.
- Tangible deliverables have been identified for specific milestones to permit progress measurements.
- Where risks have been identified, contingency plans have been prepared to deal with them.
- The project plan has been prepared with participation and/or input from individuals who must implement it.
- The project notebook has been signed off by stakeholders and copies distributed to contributors.
- A control system has been established using variance analysis to assess progress.
- Individuals have been selected for assignment to the project.
- The project has been planned to a manageable level of detail.
- A post-mortem has been done at each milestone of the project as well as a final one for the overall project and placed in the project notebook.
- The controlling project notebook has been placed in a central file for use in future project planning.
- Limits have been established to determine when the project plan will be revised.
- Checklists have been prepared for major segments of the project so that nothing is overlooked.

Adapted from Project Planning, Scheduling & Control: A Hands-on Guide to Brining Projects in on time and on budget, James P. Lewis, Probus Publishing Company, Chicago, 1991